

Smart Multivariable Transmitter

Model: JTD720A

User's Manual



Azbil Corporation

Copyright, Notices and Trademarks

© 2004-2024 Azbil Corporation. All Rights Reserved.

While this information is presented in good faith and believed to be accurate, Azbil Corporation disclaims the implied warranties of merchantability and fitness for a particular purpose and makes no express warranties except as may be stated in its written agreement with and for its customer.

In no event shall Azbil Corporation be liable to anyone for any indirect, special or consequential damages. This information and specifications in this document are subject to change without notice.

Safety

Safety instructions

Preface

Correct installation and periodic maintenance are essential to the safe use of your differential pressure transmitters.

Read the safety instructions provided in this manual carefully and understand them fully before starting installation, operation, and maintenance work.

Inspection

On delivery, make sure that the specifications are correct and check for any damage that may have occurred during transportation. This equipment was tested under a strict quality control program before shipment. If you find any problem in the quality specifications, please contact an Azbil Corporation representative immediately, providing the model name and serial number.

The name plate is mounted on the top of the enclosure.

Precautions

The following symbols are used in this manual to ensure user safety.

WARNING

Denotes a potentially hazardous situation which, if not avoided, could result in death or serious injury.

CAUTION

Denotes a potentially hazardous situation which, if not avoided, could result in operator minor injury or damage to device.

Safety messages

Installation

WARNING

- When installing the transmitter, ensure that the transmitters gaskets do not protrude from the process connection parts, such as flanges contacting the process pipes.
- Never use the transmitter in applications that are outside the rated pressure or temperature range. Always observe connection specifications. Damage to the transmitter, or leakage, may endanger plant, equipment or human safety.
- In areas designated as explosion-proof, apply to any cabling work the methods specified in the explosion-proofing guidelines.

CAUTION

- After installation, do not step on the transmitter as this may damage it, or cause physical injury.
- The glass indicator may break if hit with a tool or other object, and cause physical injury.
- Install the transmitter correctly. Incorrect installation may lead to output errors or violate applicable regulations.
- This transmitter is heavy. During installation, please ensure that your footing is safe, and always wear safety shoes.

Electrical wiring

WARNING

To avoid electric shocks, dry hands completely before performing wiring work and turning the power OFF. Wear gloves over dry hands.

CAUTION

- Before startup, study the specifications carefully and ensure that the wiring is correct. Wiring errors may cause hardware damage or other malfunctions.
- Provide a power supply that matches the specifications of the transmitter. Incorrect power supply may cause hardware damage.

Maintenance

WARNING

- Before disconnecting the transmitter from the process for any reason including maintenance, wait for safe levels in residual pressure, fluid or gas. Extreme caution should be taken to avoid fluid eruption.
- Prevent burns. Check venting or draining direction, and keep plant personnel out of the way of vented gas or drained fluid.
- When operational, never open the cover in an explosion-proof area. Avoid explosions or other combustion accidents.

CAUTION

Strict product controls were exercised during the manufacture of this transmitter. Never modify the transmitter in any way. In-plant modifications may result in damage to the transmitter or to property and human safety.

Communication equipment

CAUTION

Avoid use of communication equipment near this transmitter. Interference from such equipment as a transceiver, a cellular phone, a PHS, a beeper may result in malfunction (at some transmission frequencies). In any case, observe the following precautions:

Check in advance of using any such equipment, the clearance required to ensure safe operation of the transmitter. When using communications equipment, always maintain a distance at least equal to this distance, between the communication equipment and the transmitter.

Close transmitter cover before using communication equipment.

Unpacking, Checking, and Storage

Unpacking the transmitter

This transmitter is precision equipment. Handle it carefully to prevent an accident and damage.

Checking accessories

In the package you receive from Azbil Corporation or our representative, is included the main unit of a transmitter and the following accessories:

- One 3-inch, L-shaped wrench

Checking specifications

The specifications are marked on the transmitter nameplate. The specifications on this nameplate should agree exactly with your order. Especially, check the following:

- Tag No. (TAG No.)
- Model No. (MODEL)
- Production No. (PROD No.)
- Low and high limits of set range (RANGE)
- Supply voltage (SUPPLY)
- Explosion-proofing conformance (mark is applicable only to explosion-proof model)

Inquiry

Direct any inquiries about this transmitter to our nearest branch office or representative.

When making an inquiry, have handy a copy of the details marked on the nameplate:

- Model No. (MODEL)
- Production No. (PROD No.)

Storage

Storage over long periods requires special procedures, to avoid damage to this instrument. Always store the transmitter:

- Indoors and at normal temperature and humidity.
- In a location subject to minimum vibrations and shocks.
- Before unpacking, not after.

Precautions regarding NEPSI explosion protection

The installation, operation and maintenance of the product shall comply with the product specification and the following relevant standards and specifications.

GB/T 3836.13-2021 : Explosive atmospheres—Part 13: Equipment repair, overhaul, reclamation and modification

GB/T 3836.15-2017 : Explosive atmospheres—Part 15: Electrical installations design, selection and erection

GB/T 3836.16-2022 : Explosive atmospheres—Part 16: Electrical installations inspection and maintenance

GB 50257-2014 : Code for construction and acceptance of electric equipment on fire and explosion hazard electric equipment installation engineering

Handling precautions

For use in hazardous areas, a cable gland that is approved by NEPSI and complies with GB/T 3836.1-2021 and GB/T 3836.2-2021, with an explosion-proof grade of Ex db IIC Gb, must be used for conduit openings. The thread specification of the conduit opening is 1/2-14NPT or M20×1.5-6H. The use of the cable gland must comply with the requirements outlined in its instruction manual, and any unused conduit openings must be effectively sealed with a plugging piece.

Table of Contents

Chapter 1 : Functions, Configurations, and Structures of model JTD720A and communicator

1-1 : Function and Configuration.....	1-1
1-2 : Digital indicator (optional)	1-2
Main display	1-2
Sub display.....	1-3
1-3 : General information and procedures for configuration.....	1-5
1-4 : Field Communication Software model CFS100 Functionality and Configuration.....	1-6
1-4-1 : Introduction	1-6
1-4-2 : Precautions	1-6
1-4-3 : Configuration of Model CFS100 and Peripheral Devices	1-6
1-4-4 : Usage Environment.....	1-7
1-4-5 : Conditions for Connected Devices.....	1-7

Chapter 2 : Installation

2-1 : Installation environment.....	2-1
2-1-1 : General environmental conditions.....	2-1
Introduction	2-1
Environmental conditions.....	2-1
2-1-2 : Environmental conditions for TIIS explosion-proof transmitter.....	2-2
TIIS Explosion-proof transmitter installation precautions.....	2-2
Special condition for safe use (for NEPSI flameproof)	2-2
Environmental conditions for flameproof, special explosion-proof transmitter.....	2-2
Reference document	2-3
2-1-3 : Installing the transmitter.....	2-4
Before you install the transmitter	2-4
2-1-4 : Transmitter main unit installation position.....	2-5
2-2 : Piping	2-6
2-2-1 : Piping considerations	2-6
Introduction	2-6
3-way method valve (option).....	2-6
Extension pipe (option).....	2-6
High-pressure marking	2-7
Pipe selection	2-7
Materials and requirement.....	2-7
Piping for liquid gas or steam flow rate measurement.....	2-8
2-3 : Electrical wiring.....	2-11
2-3-1 : Wiring for general-use model.....	2-11
Introduction.....	2-11
Wiring.....	2-11

Table of Contents

Conduit pipe.....	2-12
Grounding.....	2-12
Supply power.....	2-12
2-3-2 : Wiring for explosion-proof model	2-14
2-4 : Changing process connection port position	2-15
2-4-1 : Changing the vertical position of the process connection port.....	2-15

Chapter 3 : Starting and Stopping this Device

3-1 : Operation Preparation.....	3-2
3-1-1 : Communicator Connection.....	3-2
3-2 : Tag Number Configuration and Checking various settings.....	3-3
3-2-1 : Tag Number Configuration.....	3-3
3-2-2 : Output Format Configuration.....	3-4
3-2-3 : Checking or setting the indicator display unit.....	3-4
3-2-4 : Checking or setting the lower and upper limits of indicator	3-6
3-2-5 : Damping Time Constant Configuration.....	3-7
3-2-6 : Checking or setting the design pressure.....	3-8
3-2-7 : Checking or setting the design temperatue	3-8
3-2-8 : Setting the temperature-pressure correction.....	3-9
3-2-9 : Checking or setting the static pressure elevation	3-10
3-3 : Measurement	3-11
3-3-1 : Flow Rate Measurement.....	3-11

Chapter 4 : Instrument maintenance and troubleshooting

4-1 : Assembly and Disassembly of this Device	4-1
4-1-1 : Cautions During Assembly and Disassembly	4-1
4-1-2 : Attaching and Detaching the Case Cover.....	4-2
4-1-3 : Attaching and Detaching the Main Unit Cover	4-3
4-1-4 : Cleaning the Device.....	4-4
4-2 : Calibration of the Setting Range and Output Signal	4-5
4-2-1 : Setting Range Calibration Using a Reference Input Device	4-5
4-2-2 : Calibrating the differnetial pressure sensor.....	4-7
4-2-3 : Calibrating the static pressure sensor.....	4-10
4-2-4 : Calibrating a temperature sensor.....	4-12
4-3 : Output Signal Calibration	4-13
4-4 : Troubleshooting	4-14
4-4-1 : Checking this instrument.....	4-14
4-4-2 : Checking Self-diagnostic Messages	4-15
4-4-3 : Status Message	4-16

List of Figures & Tables

Figures

Figure 1-1 Digital indicator	1-1
Figure 2-1 Name plate and conformance mark.....	2-3
Figure 2-2 Installing the transmitter	2-4
Figure 2-3 Equipment for line mounting	2-4
Figure 2-4 3-way manifold valve (Model MVG1)	2-7
Figure 2-5 Extension pipe.....	2-7
Figure 2-6 High pressure marking on center body	2-8
Figure 2-7 Piping for gas or liquid flow rate measurement	2-9
Figure 2-8 Pipe for gas or liquid flow measurement.....	2-10
Figure 2-9 Piping for steam flow measurement.....	2-11
Figure 2-10 Wiring	2-12
Figure 2-11 Supply voltage and load resistance characteristics	2-13
Figure 2-12 Connecting SFC	2-14
Figure 3-1	3-5
Figure 3-2 Items displayed on LCD.....	3-8
Figure 3-3 Flowchart of configuration data entry	3-9

Tables

Table 1-1 Operation modes of transmitter	1-5
Table 4-1 Cover Bolt and Nut Tightening Torques (N·m).....	4-3
Table 4-2 Troubleshooting.....	4-14

Chapter 1 : Functions, Configurations, and Structures of model JTD720A and communicator

1-1 : Function and Configuration

The differential pressure transmitter with temperature/pressure compensation, model JTD 720A, is designed for gas flow measurement.

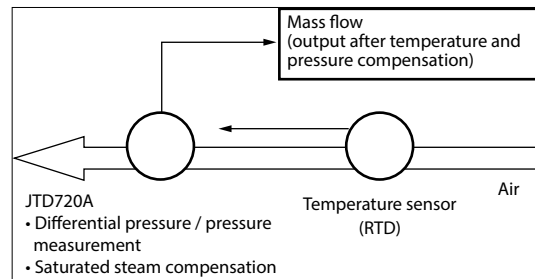

Figure 1-1 Instrumentation example of the transmitter with temperature/pressure compensation

This transmitter simultaneously measures the process differential pressure, static pressure, and temperature, and compensates for changes in density due to static pressure fluctuation and temperature fluctuation, as shown in the block diagram in figure 1-1. After compensation, it transmits an output proportional to the mass flow (the volumetric flow in Nm³ / unit of time under standard conditions).

In addition, various settings of the transmitter (differential pressure range, design pressure, design temperature, square root output, damping time constant, etc.) can be specified using the communicator.

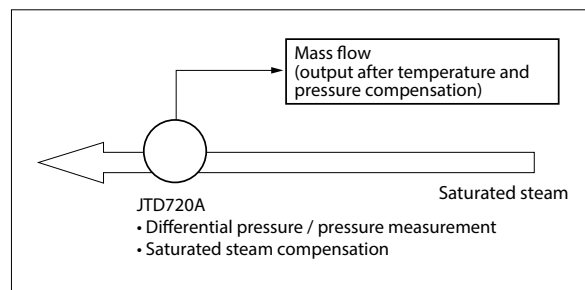

Figure 1-2 Instrumentation example of the transmitter with temperature/pressure compensation (saturated steam compensation)

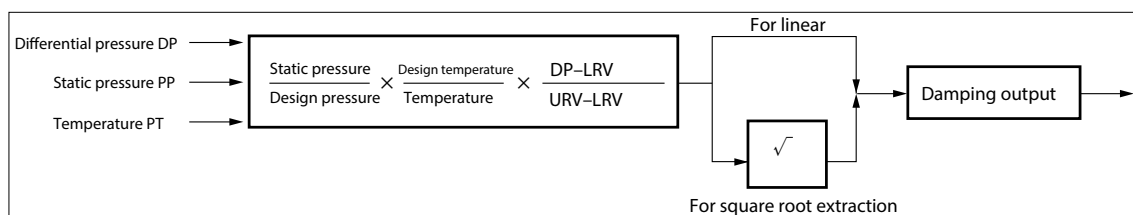

Figure 1-3 Block diagram of calculation by transmitter with temperature/pressure compensation

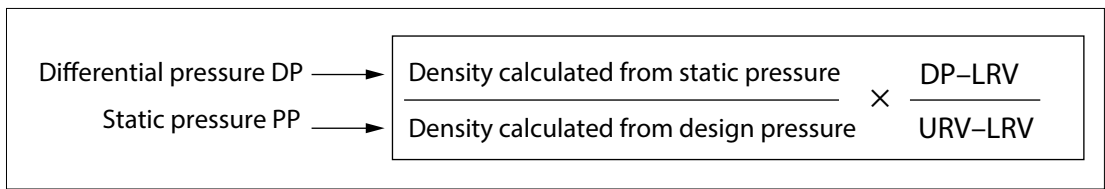

Figure 1-4 Block diagram of calculation by transmitter with temperature/pressure compensation (for saturated steam)

LRV: Lower limit of the differential pressure to output 0 % (4 mA DC)

URV: Upper limit of the differential pressure to output 100 % (20 mA DC)

1-2 : Digital indicator (optional)

The display unit of a digital indicator consists of the following:

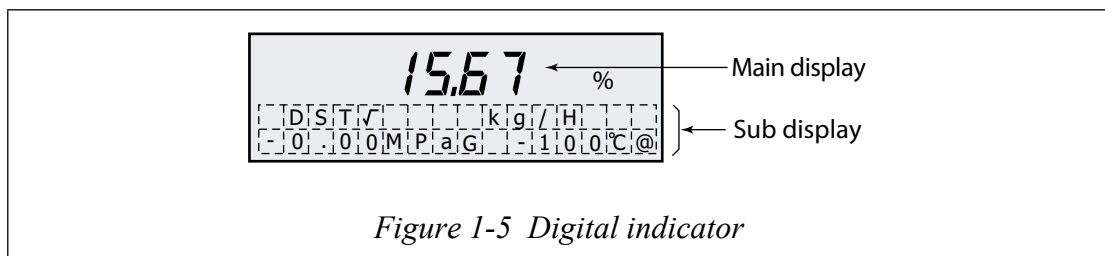

Figure 1-5 Digital indicator

Main display

The main display shows an output of a transmitter in % .

The indications in a measurement mode and in a calibration mode are as follows:

Measurement mode

Compensated output is displayed in % or engineering unit.

Calibration mode

DP mode: Displays 0 to 100% of setting DP range

PP mode: Displays 0 to 100% of setting PP range

PT mode: Displays 0 to 100% of setting PT range

OUTPUT mode

Displays the output set as constant current in %.

At DSP√, the value of which it extracts the square root is displayed.

Example: When the output is set to 50%

LIN: 50.00%

DSP√: 70.71%

OUT√: 50.00%

INPUT mode:

When the simulated value (DP,PP,TP) is input, displays the compensated output in % or engineering unit.

Sub display**Measurement mode**

Displays the liner/square root , engineering unit, process pressure, and process temperature(only connected with RTD).

It has three display modes.

LIN: Both output and display is linear
 DSP√: Output is linear, display is square root(Flow rate)
 OUT√: Both output and display is square root(Flow rate)

- ~Note**
- *When the saturated steam compensation (Options code:F2) is selected, @ is displayed in the right of °C. It is shown that it is calculated based on the vapor pressure in piping. So when steam doesn't flow, about 100°C is displayed under the atmospheric pressure condition .*
 - *% ↔ scale engineering unit scale, LIN or OUT√ ↔ DSP√ cannot be switched.*

Calibration mode

Differential pressure, static pressure or process temperature is displayed according to the mode. The mode is displayed on the lower column.

DP mode:

				2	.	6	7					k	P	a
				D	P			M	O	D	E			

- Displays present differential pressure in kPa.

PP mode:

				1	.	4	1					M	P	a
				P	P			M	O	D	E			

- Displays present static pressure in MPa (gauge pressure).

PT mode:

				2	5	.	0			D	e	g	C	
				P	T			M	O	D	E			

- Displays present process temperature in °C.

OUTPUT mode

D	S	P	√				N	m	3	/	H	
			L	O	O	P	T	E	S	T		

- Displays “LOOP TEST”.

INPUT mode:

D	S	P	√				N	m	3	/	H	
			I	N	P	U	T	M	O	D	E	

- Displays “INPUT MODE”.

1-3 : General information and procedures for configuration

The model JTD720 Differential Pressure Transmitter has six operation modes: MEASURE mode, DP mode, PP mode, PT mode, INPUT mode, and OUTPUT mode, as shown in Table 1-1. The DP, PP, PT modes are collectively referred to as CALIBRATION mode:

Table 1-1 Operation modes of transmitter

Mode		Description
MEASURE mode		The transmitter delivers an output signal which has been corrected for static pressure and temperature. Normally, the transmitter is run in this mode.
CALIBRATION mode	DP mode	The transmitter delivers an output current signal corresponding to the differential pressure input signal (4 mA (0%) for DP-LRV and 20 mA (100%) for DP-URV). This mode is used also for setting and calibration of the differential pressure sensor (setting and calibration of DP-LRV nad DP-URV).*1
	PP mode	The transmitter delivers and output current signal corresponding to the static pressure input signal (4 mA (0%) for PP-LRV and 20 mA (100%) for PP-URV). This mode is used also for setting and calibration of the static pressure sensor (setting and calibration of PP-LRV and PP-URV).*1
	PT mode	The transmitter delivers and output current signal corresponding to the temperature input signal (4 mA (0%) for PT-LRV and 20 mA (100%) for PT-URV). This mode is used also for setting and calibration of the temperature sensor (setting and calibration of PT-LRV nad PT-URV).*1
INPUT mode		The transmitter accepts simulated differential pressure, static pressure and temperature signals, and delivers an output signal that has been corrected for static pressure and temperature.
OUTPUT mode		The transmitter acts as a constant-current signal source. This mode is also used for calibration of the D/A converter

~Note *1: *For calibration, use a sufficiently accurate input signal. If you attempt zero calivration with a value more than 3% of URV (the maximum value for the measuring range of the sensor) or span calibration with a value more than 3% of the span that existed before calibration, the transmitter may exhibit symptoms similar to those exhibited by a transmitter experiencing a non-critical error.*

1-4 : Field Communication Software model CFS100 Functionality and Configuration

1-4-1 : Introduction

Model CFS100 is a configuration tool which communicates with Azbil smart devices and performs the various device configuration operations. With Model CFS100, communication is carried out by connecting a communication interface to a USB port of a PC, and connecting a communication cable to a communication terminal of an Azbil smart device.

SFN/DE communication and HART communication use their own respective special-purpose communication interfaces.

1-4-2 : Precautions

* Precautions when changing the connected device

While displaying dynamic values such as pressure, Model CFS100 continues to communicate with the device in order to update these dynamic values. If the communication cable is disconnected from the device in order to change the connected device, a communication error will occur in Model CFS100. Consequently, in order to avoid this communication error, terminate Model CFS100 before disconnecting the communication cable from the device, and restart Model CFS100 after connecting the communication cable to the new device.

* Do not use with the PC connected to an AC power supply.

* Do not connect the communication interface before installing the Model CFS100 software on the PC. It will not be able to operate normally because the driver will not be found.

1-4-3 : Configuration of Model CFS100 and Peripheral Devices

The configuration of Model CFS100 is as follows.

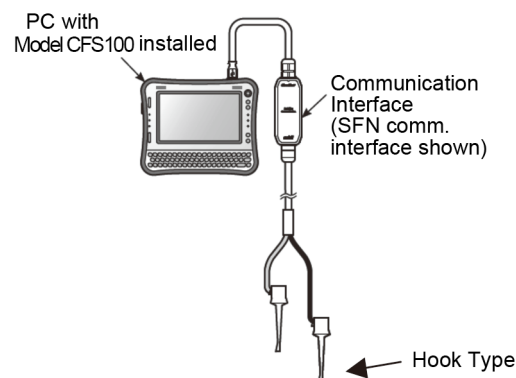

1-4-4 : Usage Environment

The usage environment of the communication interface (CFS100 SFN DE) is as shown below.

Operating temperature: 0 - 50 °C

Operating humidity: 5 - 95 %

However, if the environmental conditions of the PC being used are stricter than the conditions above, use the interface within the usage condition range of the PC.

1-4-5 : Conditions for Connected Devices

(1) PC

Check the Model CFS100 General Operation Manual.

Field Communication Software Model CFS100 User's Manual:
CFS100-2001

CM2-

(2) Communication Interface

Use a communication module that meets the following conditions.

SFN/DE communication interface	CFS100 SFN DE Azbil product model number <ul style="list-style-type: none"> • 80345962-001 (alligator clip type) • 80345962-002 (easy hook type)
--------------------------------	---

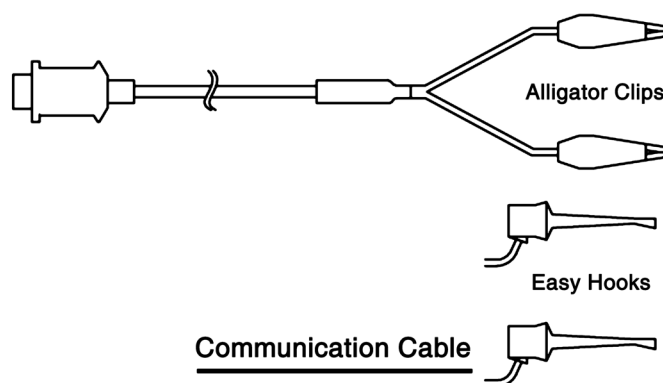

Chapter 2 : Installation

Overview of chapter 2

Instructions for the installation of pipes and cables associated with this transmitter. Also covers installation of the transmitter. For users that are responsible for installation work.

2-1 : Installation environment

2-1-1 : General environmental conditions

Introduction

Install under environmental conditions specified here, to fully exploit transmitter performance over long periods.

Always install an explosion-proof transmitter where regulations demand such precautions.

When installing explosion-proof models, follow the guidelines in Recommended Practices for Explosion-Protected Electrical Installations in General Industries (2006, for gases and vapors) or Users' Guidelines for Installations for Explosive Atmospheres in General Industry, which are technical recommendations from the National Institute of Occupational Safety and Health.

Environmental conditions

Select a location to meet the following conditions:

- Temperature fluctuations should be as small as possible
- Avoid installing in locations that are exposed to radiated heat from other plant equipment.
- Insulate against freezing in the measured fluid or sealing liquid.
- Select a location where shocks and vibrations are as small as possible.
- Avoid installing in corrosive atmospheres.
- External zero-adjustment function is an option that may be subject to output fluctuations if installed near to sources of strong magnetic interference. Install such models at least 1 m remote from plant equipment producing strong magnetic interference as over 10 gauss measured where a motor or a pump is installed.

2-1-2 : Environmental conditions for TIIS explosion-proof transmitter

TIIS Explosion-proof transmitter installation precautions

TIIS Explosion-proof transmitters have passed inspections at a public organization in compliance with Japanese Labor Safety and Hygiene Laws. As specified, use explosion-proof transmitters in hazardous locations. Smart Transmitters are available in two types of explosion-proof specifications: flameproof, special explosion-proof specifications and intrinsically-safe specifications.

Explosion-proof transmitters have a conformance mark that provides required information for explosion-proof performance. Install explosion-proof transmitters correctly, and follow the information on the name plate.

Special condition for safe use (for NEPSI flameproof)

- The terminal cover has at least 9 engaged threads.
- The cover (with or without window) has at least 9 engaged threads.
- The housing has at least 10.5 engaged threads.

Environmental conditions for flameproof, special explosion-proof transmitter

Install a flameproof, special explosion-proof transmitter in locations that meet the following explosion class, ignition temperature, and hazardous environment class conditions:

- Explosion class and ignition temperature of gas:
IIB + H₂T₄ (IIB + H₂T₄: Gas equivalent to IIC, steam and Hydrogen
T₄: Gas and steam whose ignition temperature is 135°C or higher.)
- Hazardous area classification:
Hazardous Zones 1 and 2
Do not install this device in Zone 0.
- Temperature
Select a location where the temperature always stays under high limits specified by the conformance mark. AMBIENT TEMP refers to the ambient temperature of the transmitter and METER BODY TEMP refers to the temperature of the meter body that is in contact with the liquid. The low limit is -15°C for both ambient temperature and meter body temperature.

Temperature precautions

The transmitters explosion-proof performance cannot be guaranteed outside these temperature limits. If temperature should exceed the high limits, install insulation and ventilation, to maintain the effective operating temperature.

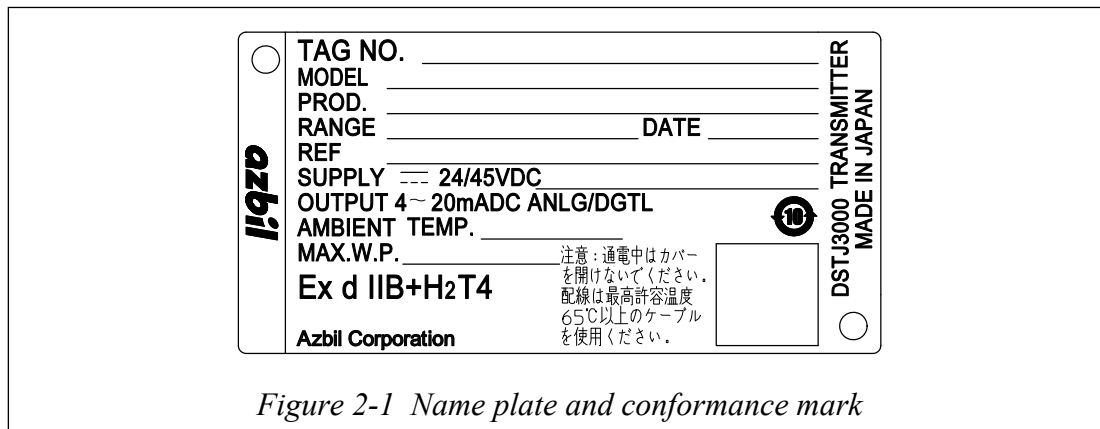

Reference document

Recommended Practices for Explosion-Protected Electrical Installations in General Industries (Technical Recommendation of the National Institute of Occupational Safety and Health)

2-1-3 : Installing the transmitter

Before you install the transmitter

Prepare the following items:

- 2-inch pipe
- Mounting bracket (U-bolt, nut, mounting bolt) (Option)

The transmitter can be installed by the following two methods:

- Installation with pipe stanchion (Refer to Figure 2-2)
- Installation by line mounting (Refer to Figure 2-3)

In the both cases, fix the transmitter to a vertical or horizontal 50 mm pipe with a U-bolt using a mounting bracket. Mounting transmitter on a bracket using the four bolt holes on the reverse side of the pressure receiving part. Fix the pipe firmly to the foundation and make sure that it is stable. When you choose the line mounting method, provide equipment to be used for connecting a 2-inch pipe to the line pipe.

~Note *As for the procedure for mounting a transmitter on the 2-inch pipe, not that the sequence of assembling the transmitter, the bracket, and the 2-inch pipe depends on the installation direction.*

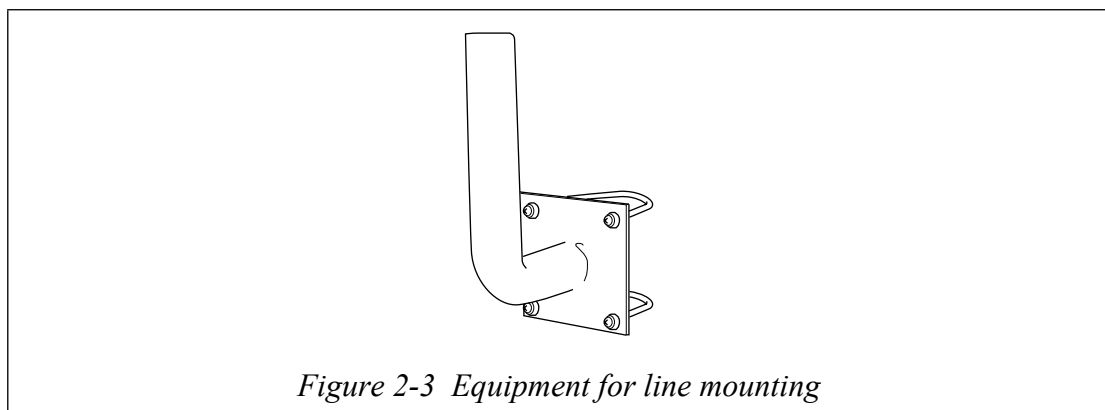
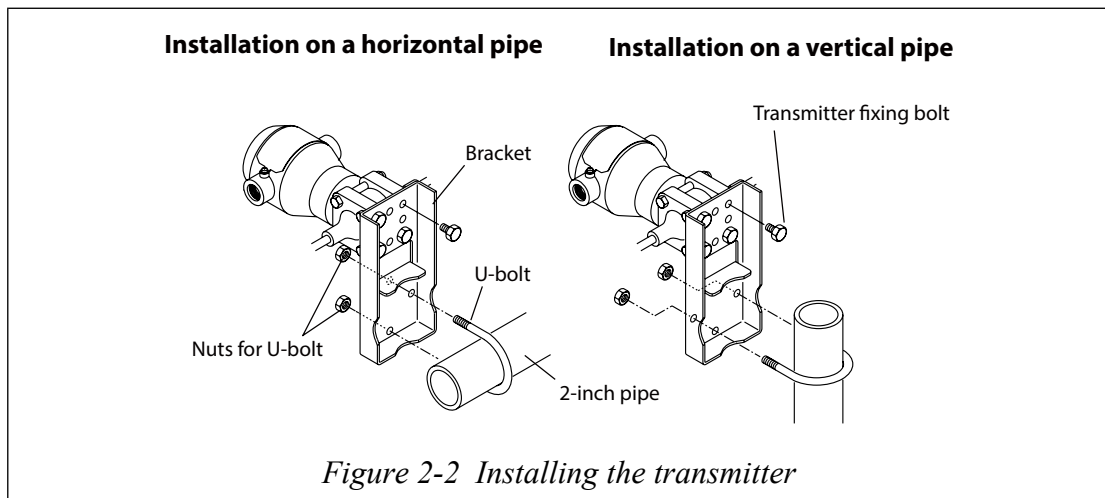

2-1-4 : Transmitter main unit installation position

No special restriction is imposed on the installation position, it is the best to install the transmitter main unit in such a way as to set the pressure receiving diaphragm vertically. After installation, calibrate the zero point by the following procedure.

Perform zero point calibration by the following procedure:

1. Fix the high pressure and low pressure side diaphragms at the same height and make sure that the input pressure to the transmitter is uniform.
2. Using model CFS100, check the output of this device. If the output is not zero, adjust the zero point.

2-2 : Piping

2-2-1 : Piping considerations

Introduction

Piping method depends on such conditions as transmitter position and pipeline installation. It is generally sufficient to use a 3-way manifold valve and connect an extension pipe.

Since the model JTD720A has separate connector ports for high and low pressure, distinguish them correctly for installation work. A 3-way manifold valve is optional.

3-way method valve (option)

A regular, 3-way manifold valve is shown in the following illustration:

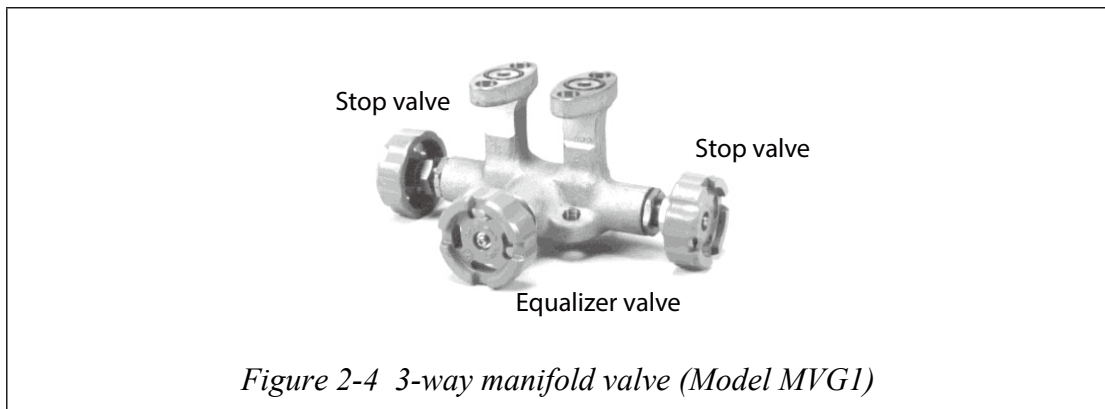

Extension pipe (option)

Both straight extension pipe and union extension pipe shown below, are available.

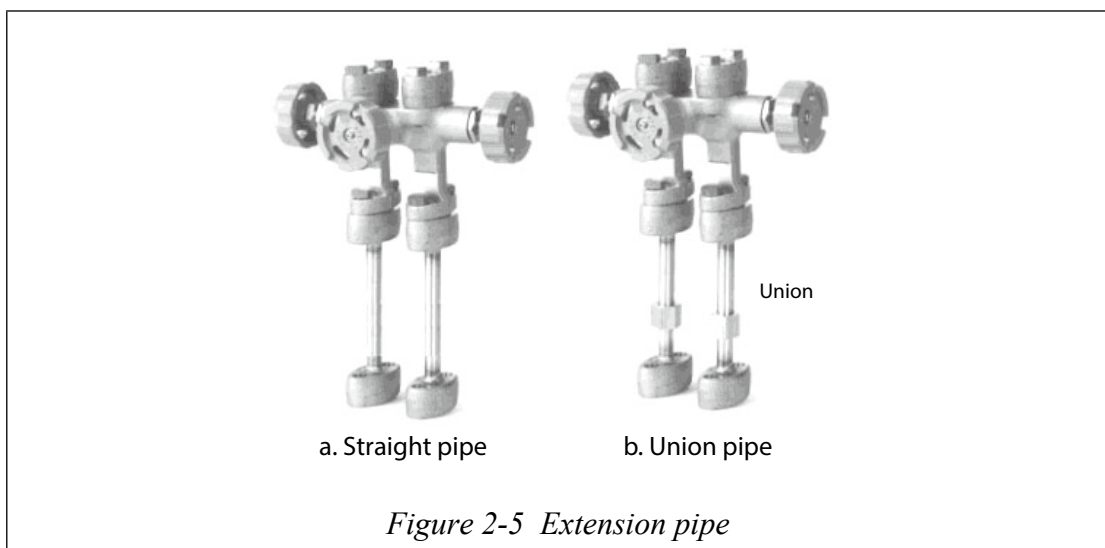

High-pressure marking

H indicates high pressure on the center body. Check the mark to ensure correct installation, during piping work. The low pressure side has no mark.

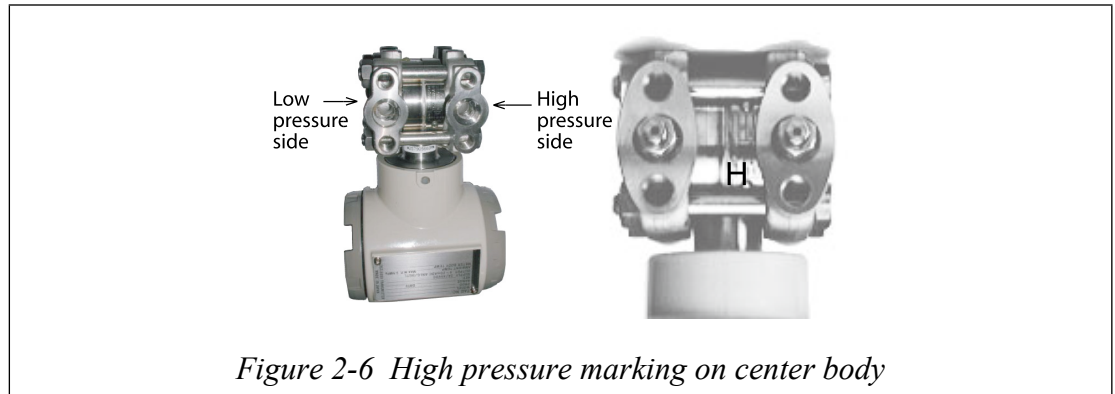

Pipe selection

Select a schedule number and nominal thickness for the connecting pipe leading from a process, based on such conditions as process pressure.

For example, use a 1/2-inch, steel pipe with a schedule number 80.

Materials and requirement

Prepare in advance the following parts and always refer to the illustration.

- 3-way manifold valve
- Pipe
- Main valve
- Union or flange
- Tee
- Drain valve
- Drain plug
- Vent plug
- Seat pot (for steam flow rate measurement only)

Piping for liquid gas or steam flow rate measurement

Important!

Incline the pipe at the differential pressure output part.

Indication symbol  in illustration: Lower position  Higher position.

After piping work, ensure that the connection pipe, the 3-way manifold valve, and the transmitter have no pressure leak.

The illustration shows a typical example of piping. This transmitter is located below the differential pressure output port of the process pipe.

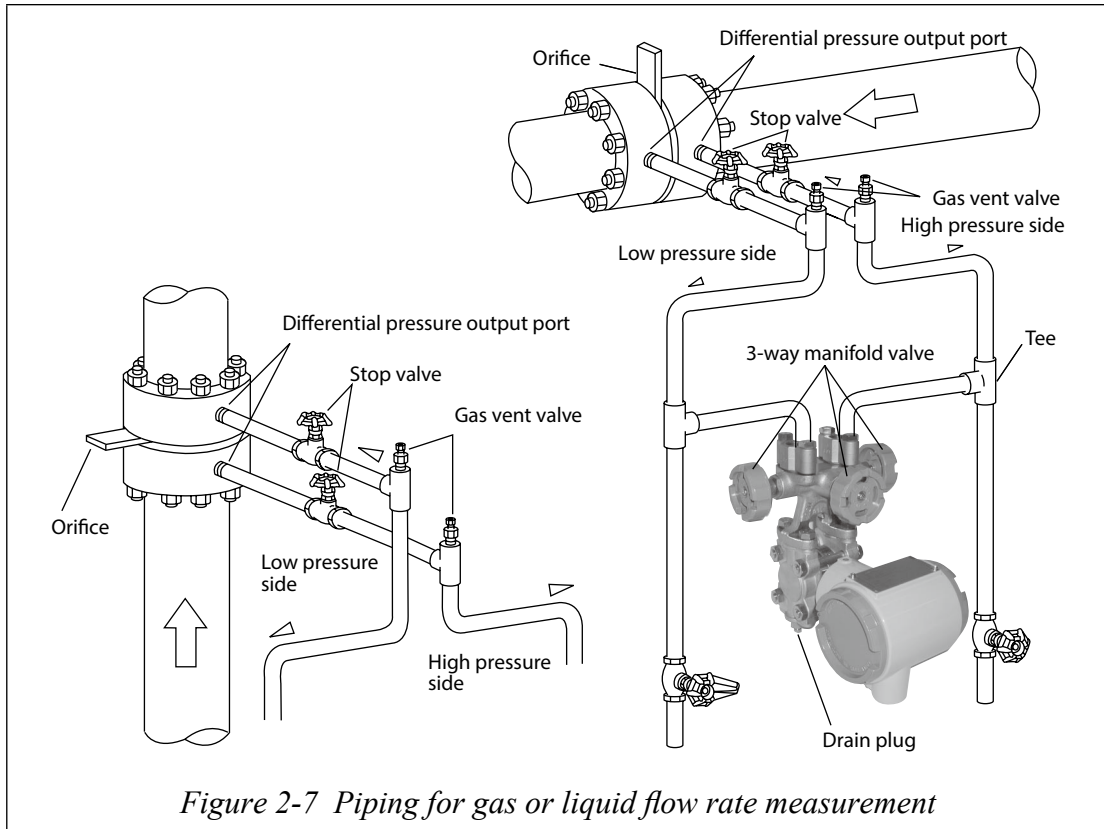

The illustration shows a typical example of piping for the transmitter located above the differential pressure port of the process pipe.

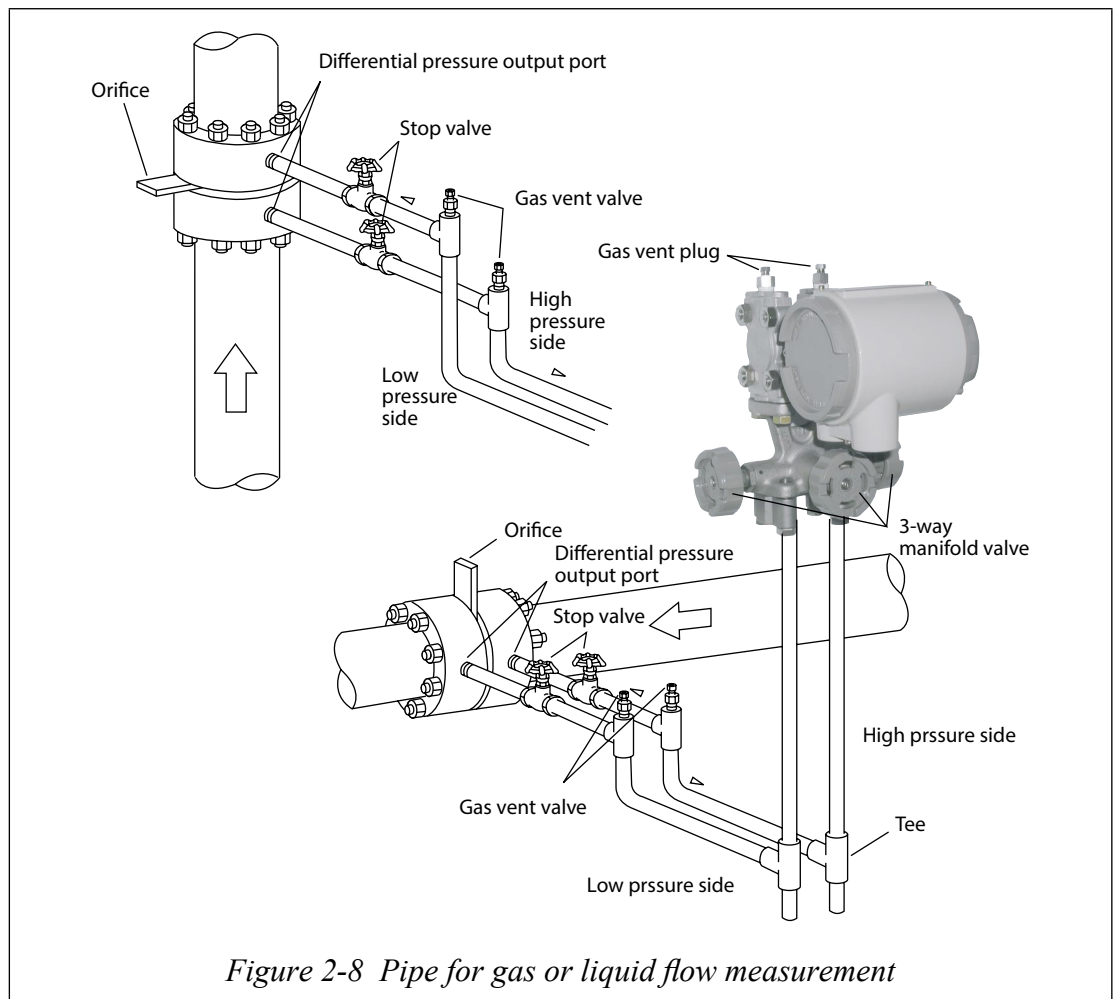

The illustration shows a typical example of piping for steam flow that the transmitter is located below the differential pressure output port of the process pipe.

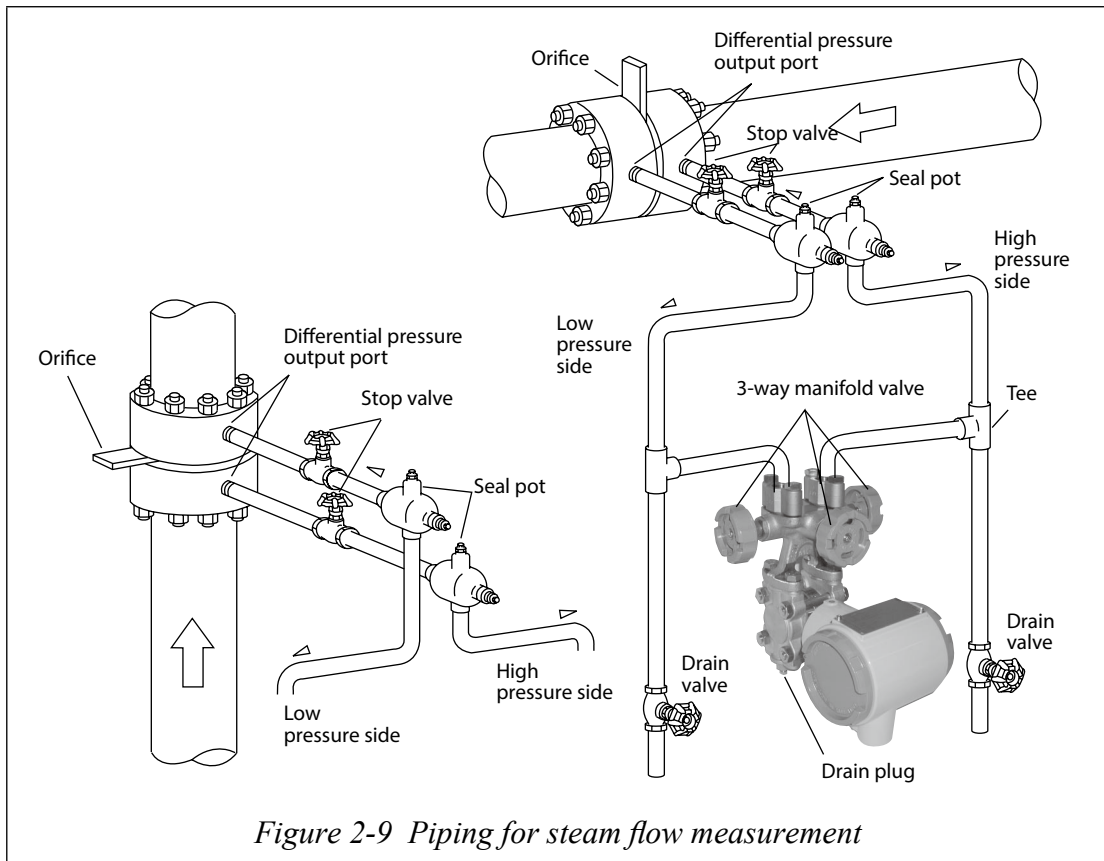

Figure 2-9 Piping for steam flow measurement

For vertical piping, installing the seal pots at stepped positions as shown in the figure can prevent zero drift of the differential pressure gauge, which otherwise is apt to occur. Note that, with stepped seal pots, it is not possible to adjust the zero point in the usual way using a 3-way manifold valve. Use model CFS100 to adjust a zero point that shifted when seal pots at stepped positions were filled with water.

2-3 : Electrical wiring

2-3-1 : Wiring for general-use model

Introduction

This shows wiring instructions of the transmitters.

Wiring

Wire and cable this transmitter as shown in the instructions.

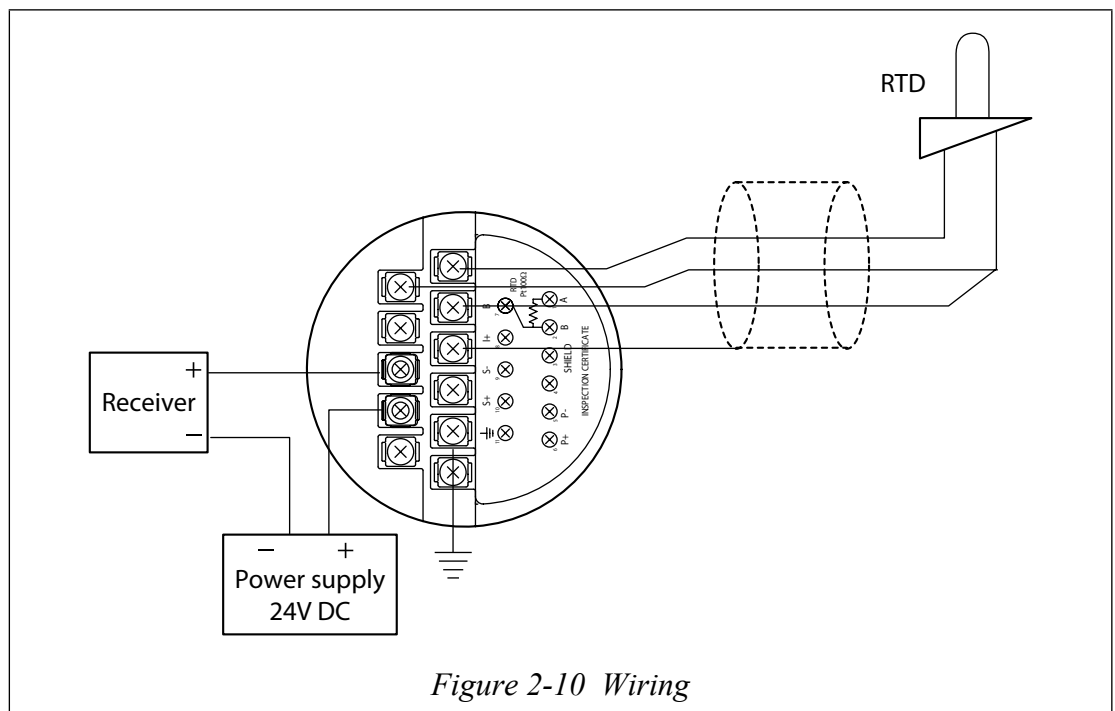

~Note *Load resistance of at least 250 Ω is required for communicator. If total load resistance of the receiver is less than 250 Ω , install the necessary resistance to the loop.*

Conduit pipe

Lead cables into the transmitter case as follows;

Install a conduit pipe in the electrical conduit (G1/2 female thread) provided on the side of a transmitter, and lead cable through the pipe.

Seal the part that contacts with the conduit pipe using a sealing agent or a seal plug to positively prevent entry of water.

Install transmitter so that the cables lead into it, from the bottom.

If required, use a special elbow to change cabling direction.

Connect RTD (PT100 or JPT100) wires as shown in the figure using sealed cable. If temperature compensation is not required, this RTD is not necessary.

- ~Note**
- 1. If temperature compensation is used and the terminal is open, the device will be diagnosed with a critical failure in self-diagnosis.*
 - 2. It may take 5 minutes or more for stable input after connecting RTD to the transmitter.*
 - 3. The maximum cable length between the transmitter and the RTD is 20 m.*

Grounding

Two ground terminals are provided. One terminal is on the terminal, and the other is outside the transmitter. Ground either one.

Connect a ground terminal with a ground resistance not higher than 100 Ω .

Grounding is essential when installing explosion-proof transmitter.

Directly ground welding machine and transformer, for its power supply. Never connect such equipment by ground terminal to the stanchion pipe that holds a transmitter. Welding current may influence measurements.

Supply power

Confirm the relationship between the external load resistance and the supply voltage. As shown in the illustration, the relationship should be inside the shaded area.

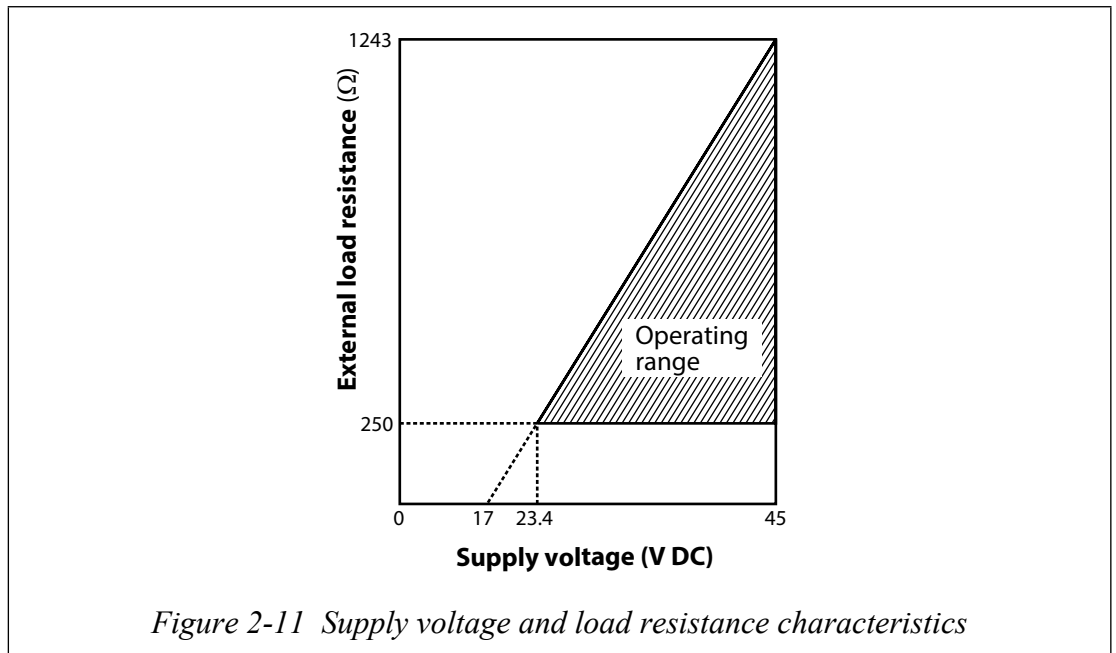





Figure 2-11 Supply voltage and load resistance characteristics

2-3-2 : Wiring for explosion-proof model

Guideline Wire explosion-proof models while referring to 2-3-1, “Wiring for general-use model” and the explanation below. When installing explosion-proof models, follow the guidelines in Recommended Practices for Explosion-Protected Electrical Installations in General Industries (2006, for gases and vapors) or Users’ Guidelines for Installations for Explosive Atmospheres in General Industry, which are technical recommendations from the National Institute of Occupational Safety and Health.

 CAUTION	
	This device has undergone explosion-proof testing and obtained certification, with the condition that the pressure-resistant packing cable adapter included with this device must be used as part of the transmitter case. Therefore, if a cable adapter other than the included one is used for external wiring, this device’s explosion-proof performance is not guaranteed.
	Tighten the case cover all the way and lock it. For explosion-proof models, locking the lid of the transmitter case is required.

Lock

This instrument has a locking structure. Before wiring, unlock the transmitter case using an M3 mm hexagon wrench.

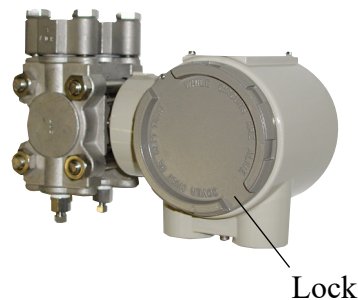

Figure 2-12 Transmitter case lock

Connecting external wires

When running cables into this device, use the included pressure-resistant packing cable adapter shown in the figure below or a conduit fitting. Use cables that are temperature-resistant to at least 65 °C



Figure 2-13 Pressure-resistant packing cable adapter

2-4 : Changing process connection port position

2-4-1 : Changing the vertical position of the process connection port

Introduction

When this device was shipped, the process connection port was positioned on the center body cover as specified in your order. The up/down position can be changed. This section describes how to change the position of the process connection port from the bottom of this device to the top.

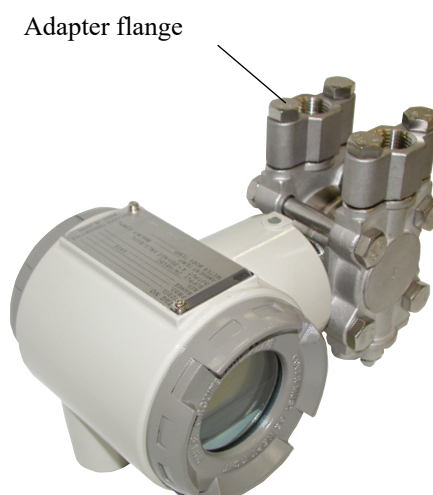

Figure 2-14 Changing process connection port position

Procedure					
1. Remove the four bolts that hold the two adapter flanges.					
2. Remove the two vent/drain plugs.					
3. Attach the two adapter flanges to the top of this device with bolts. Tighten the bolts to the specified torque.					
Specified torque:	<table style="border: none;"> <tr> <td style="padding-right: 20px;">SNB 7, SUS 630</td> <td style="text-align: right;">20±1 N·m</td> </tr> <tr> <td>SUS 304</td> <td style="text-align: right;">10±0.5 N·m</td> </tr> </table>	SNB 7, SUS 630	20±1 N·m	SUS 304	10±0.5 N·m
SNB 7, SUS 630	20±1 N·m				
SUS 304	10±0.5 N·m				
4. Apply seal tape around the threads of the two vent/drain plugs and spray lubricant.					
5. Screw the vent/drain plugs into the bottom of this device. Tighten the plugs to the specified torque 5 ± 0.3 N·m.					

Use the same procedure (making the necessary changes) when moving the connection port from the top to the bottom.

Chapter 3 : Starting and Stopping this Device

Caution



If the transmitter uses SFN communication while the process is in the automatic control state, the output may fluctuate, and the device may enter a dangerous operating state. Before performing this operation, be sure to switch the control loop of the process to manual control.

In this chapter, the following items will be described.

- Connecting a Communicator to this Device
- Verifying Settings such as the Required Tag Number, the Output Format of this Device, etc., during Receiving Inspection
- Preparations before Measurement
- Starting and Stopping Measurement
- Items Necessary when Stopping this Device for Maintenance and Replacement

For information regarding communicator usage, see the operation manual for the relevant device.

Field Communication Software Model: CFS100 (Common Edition) User's Manual :
CM2-CFS100-2001

Field Communication Software Model: CFS100 Instruction Manual (Smart Transmitter Model JTD720A Edition :
CM2-CFS100-2007

Advanced Transmitter(HART Version 5)

Before connecting to this device, be sure to read the operation manual carefully.

3-1 : Operation Preparation

3-1-1 : Communicator Connection

The figure below shows the wiring when connecting a communicator to this device. Connect the communication cables to the transmitter terminals as follows.

Red cable: Supply + terminal

Black cable: Supply - terminal

~Note *External load resistance must be at least 250 Ω for the communication.*

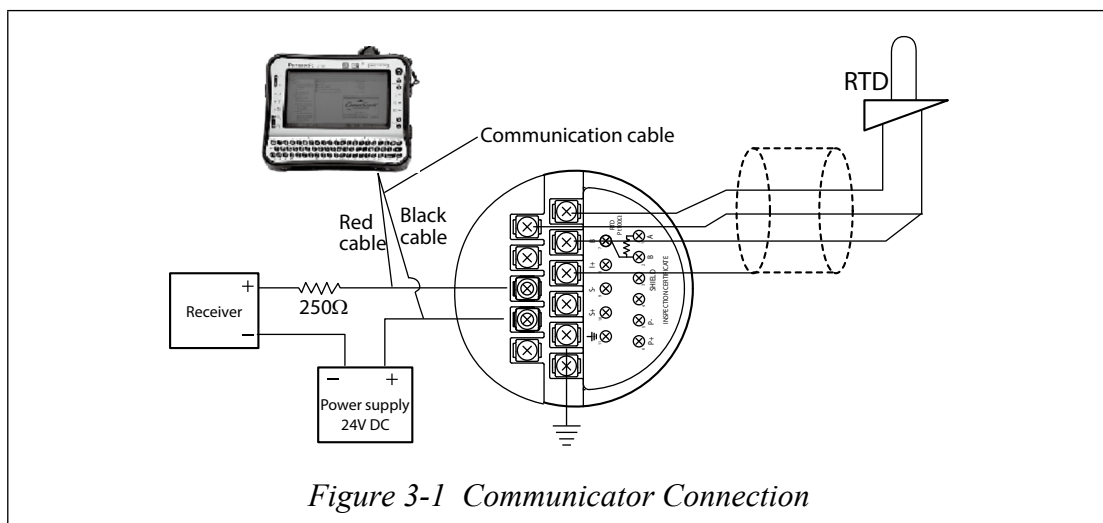

3-2 : Tag Number Configuration and Checking various settings

3-2-1 : Tag Number Configuration

This section explains how to input or change the tag No. In the menu tree in the left pane, select [Device Setup] → [Basic setup] → [Tag].

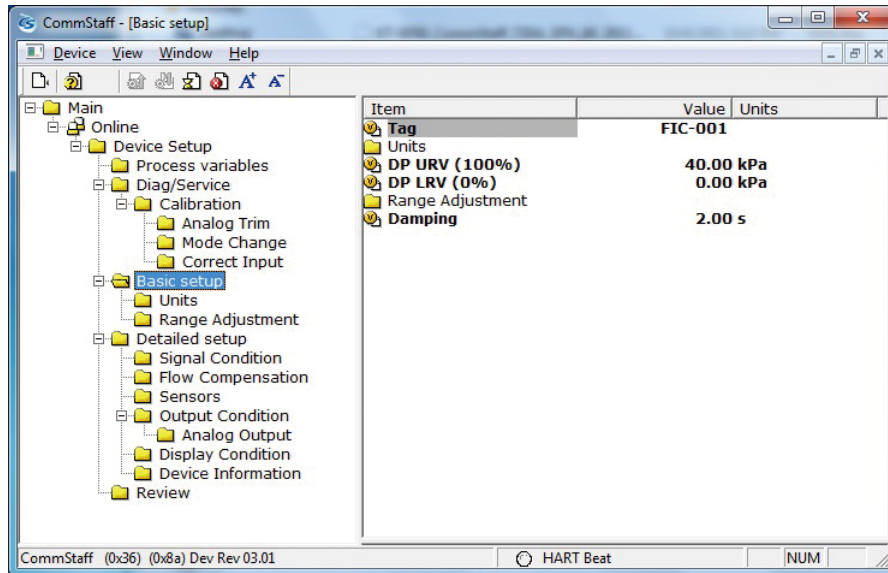

Double-clicking Tag displays the settings screen. On this screen, set the Tag and click the Set button. The tag is highlighted in yellow. Click the Send button to send the new Tag to the transmitter.

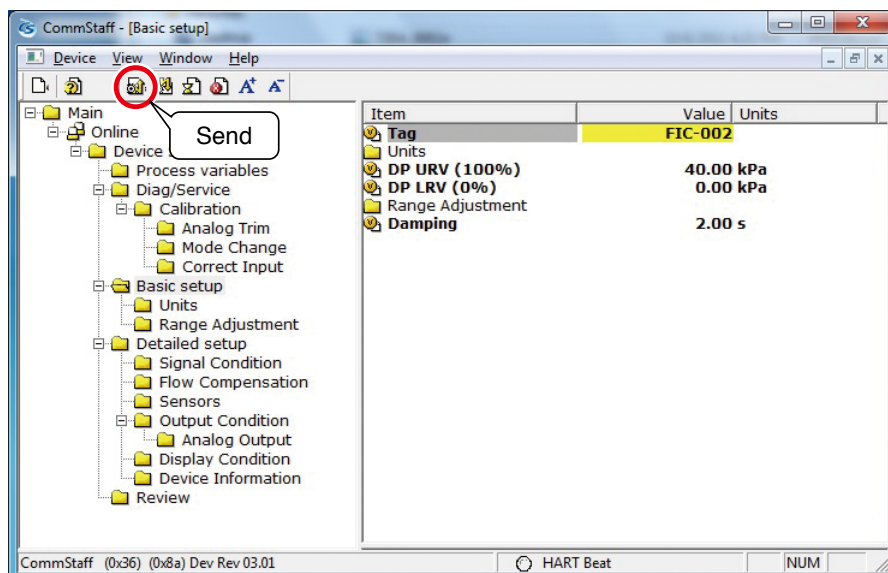

3-2-2 : Output Format Configuration

Checking or setting Linear/ Sq root output

This section explains how to switch between linear and square root output.

Select [Device Setup] → [Detailed setup] → [Signal Condition] → [Conformity].

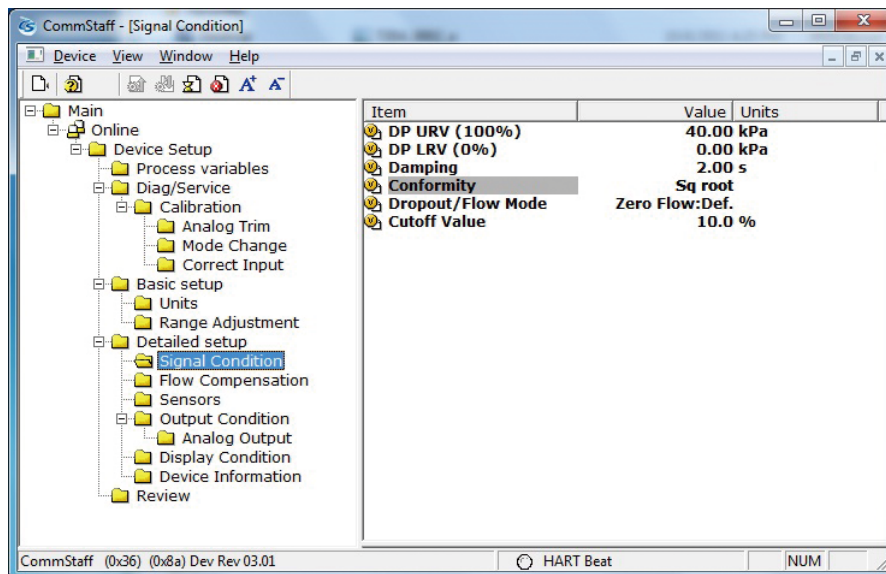

Double-clicking [Conformity] will display a dialog box for selection of one of the following items.

Linear / Sq root

After selecting, click the <Set> button. After the dialog box closes, click the <Send> button.

3-2-3 : Checking or setting the indicator display unit

First, the display unit should be set to either % or engineering unit (Eng. Unit) under the Disp. Unit item.

Select [Device Setup] → [Detailed setup] → [Display Condition] → [Disp. Unit].

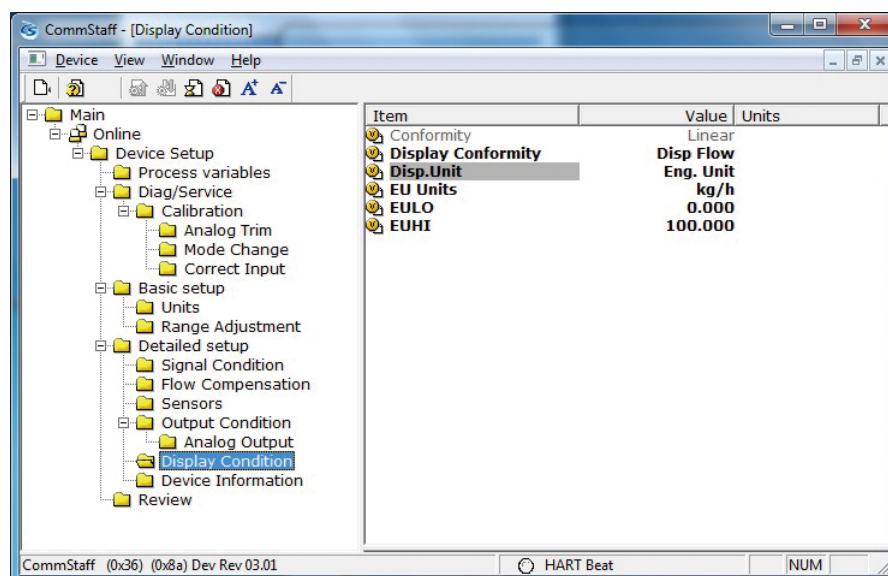

Note: If the software version of the device is Ver.7.7 or earlier then this item is not supported and so is not displayed. To set to % display, configure in EU Units.

If Disp. Unit is set to Eng. Unit, next make a selection for EU Units.

Select [Device Setup] → [Detailed setup] → [Display Condition] → [EU Units].

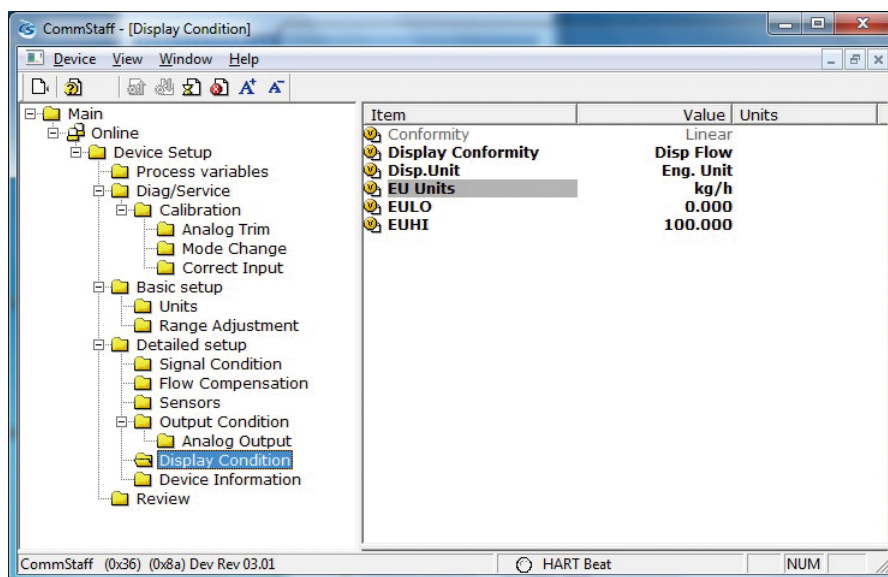

The following units are available. For use in Japan, select an SI unit

gal/s	l/s	Ft ³ /s	m ³ /s	Ft ³ /min
gal/min	l/min	IGPM	m ³ /min	cm ³ /min
m ³ /h	ImpG/h	cm ³ /h	l/h	gal/h
MilG/d	MilL/d	Ft ³ /d	m ³ /d	ImpG/d
BPD	gal/d	kgal/d	l/s	l/min
l/h	l/d	kl/s	kl/min	kl/h
kl/d	m ³ /s	m ³ /min	m ³ /h	m ³ /d
Nm ³ /s	Nm ³ /min	Nm ³ /h	Nm ³ /d	t/s
t/min	t/h	t/d	g/s	g/min
g/h	kg/s	kg/min	kg/h	kg/d
MetT/min	MetT/h	MetT/d	lb/s	lb/min
lb/h	lb/d	ShTon/m	Shton/h	ShTon/d

Note: If the device software version is 7.7 or earlier, select % or engineering unit (Eng. Unit) for “EU Units.”

When set to % display, the device displays 0 to 100% regardless of the EULO and EUHI values.

3-2-4 : Checking or setting the lower and upper limits of indicator

EULO and EUHI values are the upper and lower limits for engineering units (scale readings) displayed on the indicator. They are displayed in the range of -19999 to +19999.

Select [Device Setup] → [Detailed setup] → [Display Condition] → [EULO]/[EUHI].

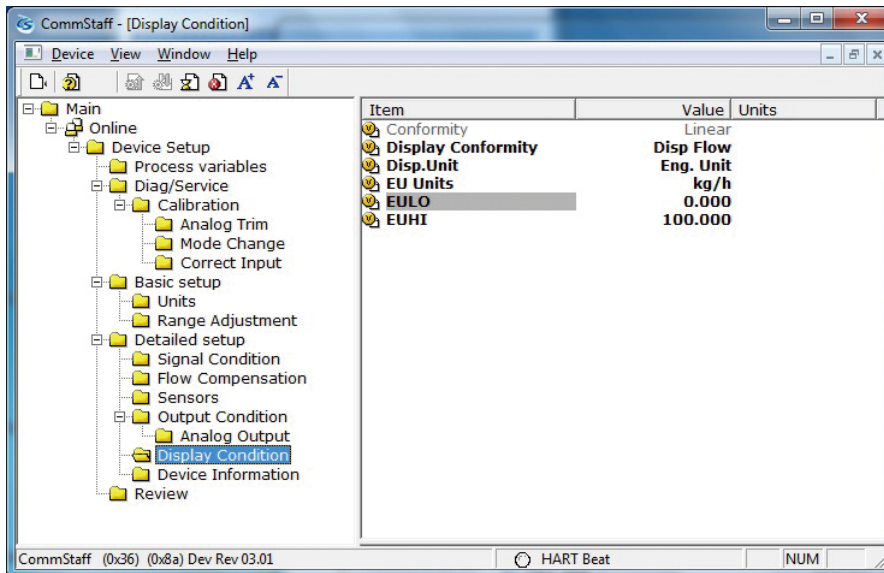

3-2-5 : Damping Time Constant Configuration

This section explains how to configure the damping time constant.

Select [Device Setup] → [Basic setup] → [Damping].

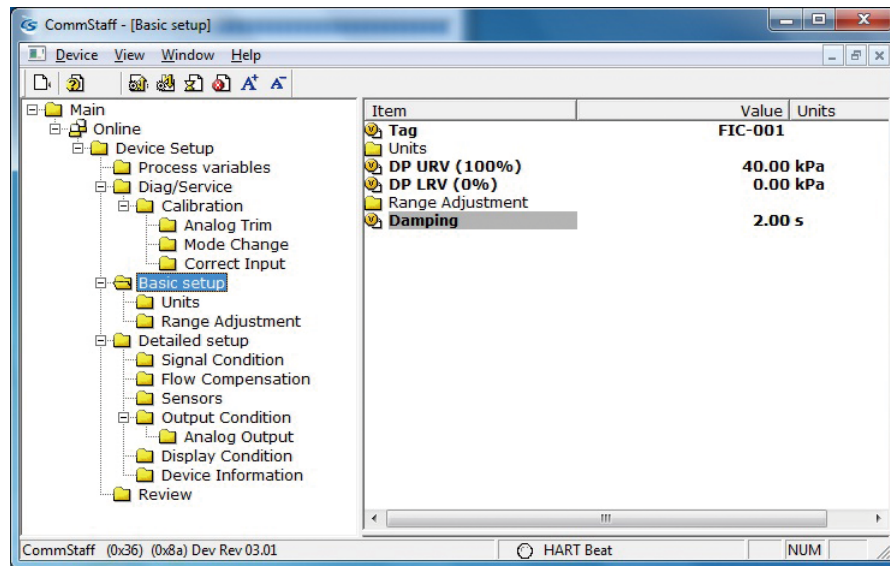

The following values can be input. If a value other than the following is input, the closest value is automatically selected.

Unit:s

0.0
0.16
0.32
0.48
1.00
2.00
4.00
8.00
16.0
32.0

3-2-6 : Checking or setting the design pressure

When Compensation Formula is set at Pressure comp. or Temp. pressure comp., it is effective. It is also effective when the measured gas is set to Saturated Steam.

Select [Device Setup] → [Detailed setup] → [Flow Compensation] → [Ref. PT].

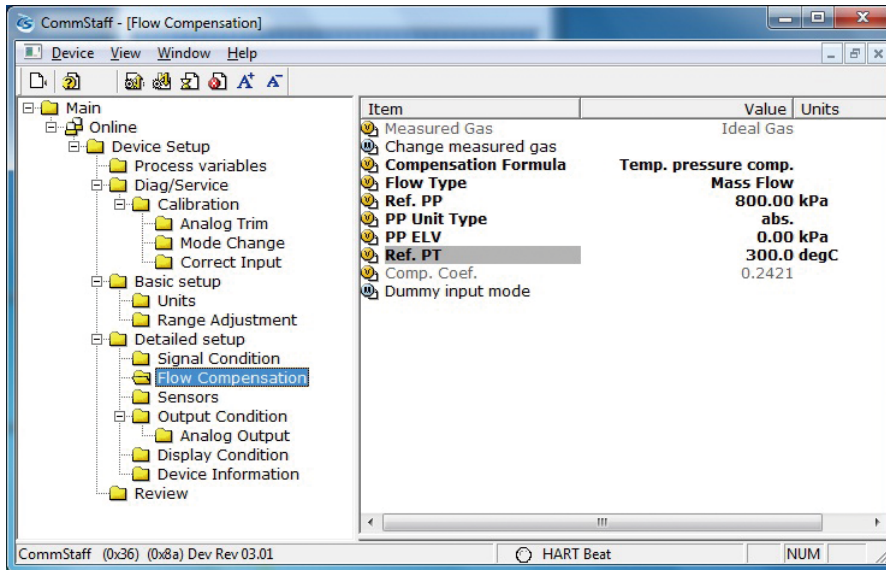

3-2-7 : Checking or setting the design temperature

When Compensation Formula is set at Temp comp. or Temp. pressure comp., it is effective.

Select [Device Setup] → [Detailed setup] → [Flow Compensation] → [Ref. PT].

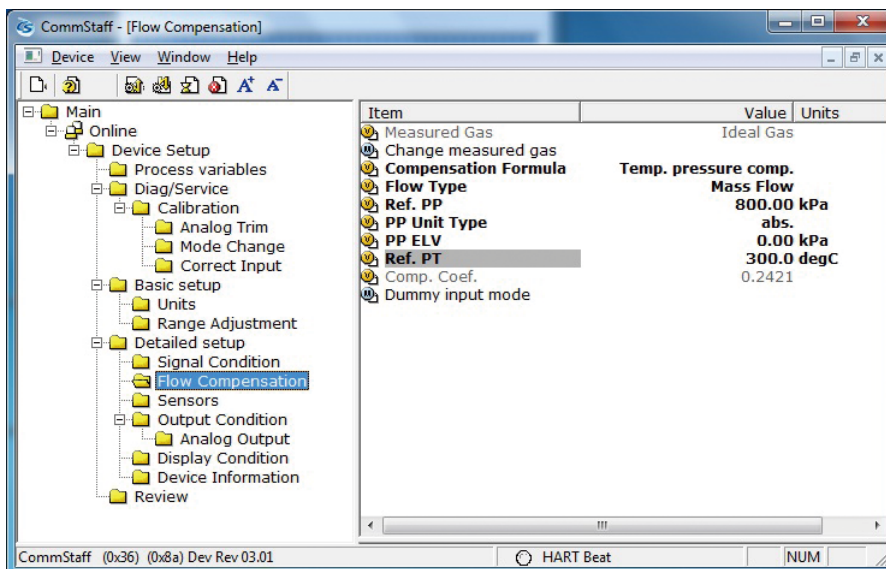

3-2-8 : Setting the temperature-pressure correction

Checking or setting the formula

If the measured gas is an ideal gas, the formula can be changed, but if it is saturated steam, the formula cannot be changed.

Select [Device Setup] → [Detailed setup] → [Flow Compensation] → [Compensation Formula].

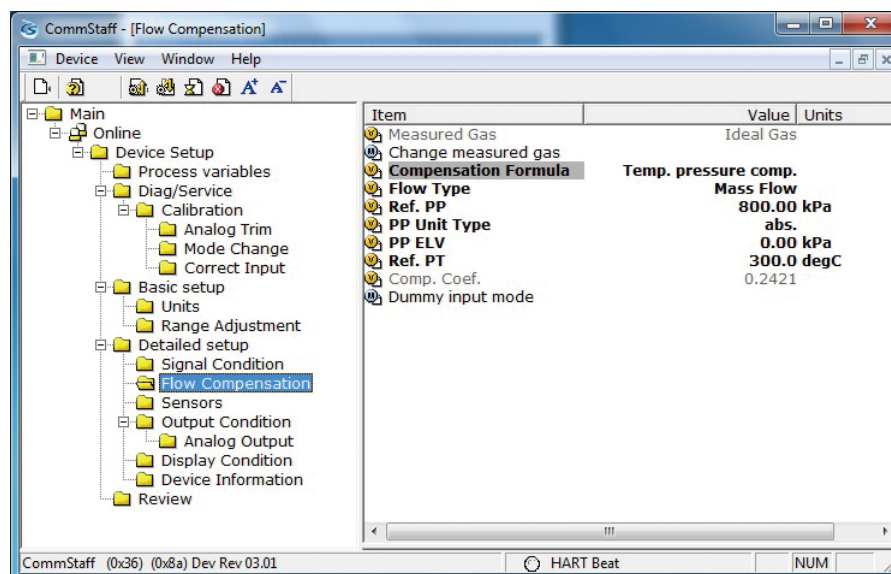

The formula can be selected from the following.

No comp	No correction
Pressure comp.	Pressure correction
Temp. comp.	Temperature correction
Temp. pressure comp.	Temperature and pressure correction

3-2-9 : Checking or setting the static pressure elevation

When Compensation Formula is set at Pressure comp. or Temp. pressure comp., it is effective. It is also effective when the measured gas is set to Saturated Steam.

Select [Device Setup] → [Detailed setup] → [Flow Compensation] → [PP ELV].

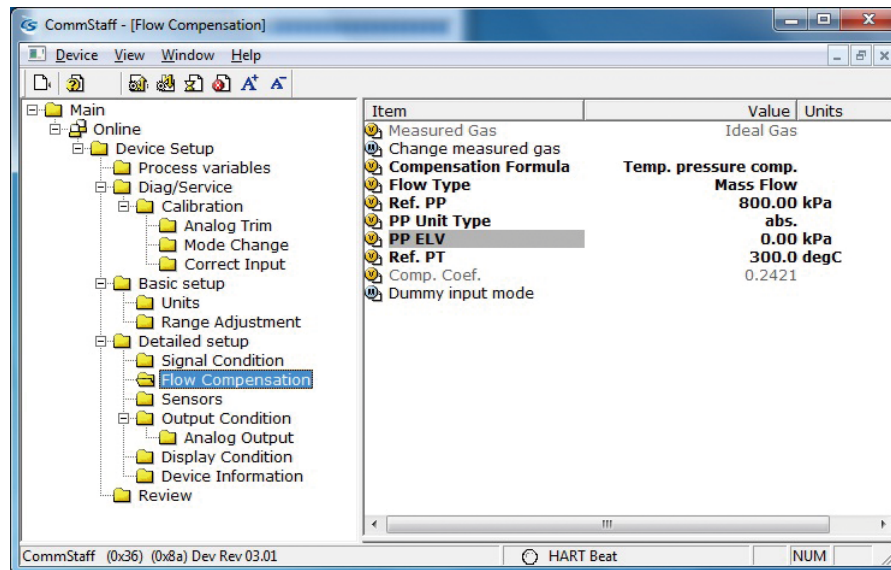

3-3 : Measurement

3-3-1 : Flow Rate Measurement

(1) Preparing for Operation

(i) Important points

Warning



When clearing vents and drains, check the direction in which material will come out in order to avoid any contact with the human body. There is a danger of scalding and other harmful health effects. If the process fluid is harmful to the human body, take safety measures such as wearing goggles or a mask so that it does not adhere to the skin or the eyes, become inhaled, etc.

Caution



Check that the process is in manual control mode. If it is in automatic control mode, be sure to switch it to manual control mode before starting work.



In terms of piping, before commencing operation of this device as shown below, the differential pressure outlet valves (master valves), drain valves, gas vent plugs (see Figures 2-30 and 2-31) and the stop valve of the three-way manifold valve must be closed on both the high pressure and low pressure sides. In addition, check that the equalizer valve of the three-way manifold valve is open.

(ii) Introducing process pressure and checking for leaks

In the following procedure, process pressure is introduced into the pressure-receiving part of this device.

◆ Procedure ◆

- (1) Open the high and low pressure side master valves (see Figures 2-30 and 2-31), and introduce process fluid into the connecting pipe. If the process temperature is high at this point, wait until the connecting pipe cools down.
- (2) Fill the pressure-receiving part of the device with process fluid.
 - (1) Gradually open the stop valve on the high pressure side. When it is filled with process fluid, close the valve.

- (2) Gradually open the stop valve on the high pressure side. When it is filled with process fluid, close the valve.

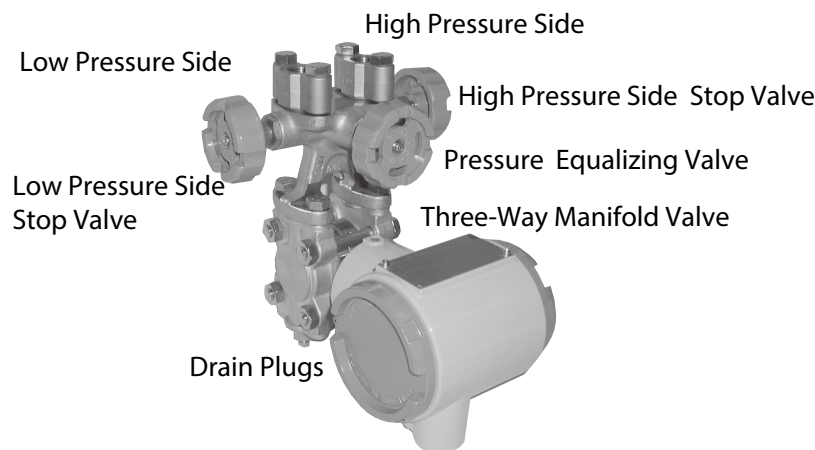

- (3) Set the differential pressure applied to the device to zero.
Gradually open the equalizer valve. Next, gradually open the high pressure side stop valve, and introduce process pressure into the pressure-receiving part of the device. The device will attain a state (the equalized pressure state) in which equal pressure will be applied to the high pressure side and low pressure side of the device.
- (4) Check that there are no pressure leaks in the connecting pipes, the three-way manifold valve, the device itself, etc.

(iii) Zero point check and calibration

◆ Procedure ◆

- (1) Check that, in the previous operation, the equalized pressure state was attained.
- (2) Using the communicator, check the device output. If the output is not zero, calibrate the zero point. For information regarding the zero point calibration procedure, see the operation manual for the communicator.

Note: Have the required equipment on hand before starting zero-point calibration.

(2) Starting Operation

(i) Applying process pressure

In the following procedure, valves are operated to apply the differential pressure of the process to this device, and then the measurement value is checked using the communicator.

◆ Procedure ◆

(1) Check that the valves of the three-way manifold valve are in the following state.

- (1) High pressure side stop valve: fully open
- (2) Low pressure side stop valve: fully closed
- (3) Equalizer valve: fully open

(2) Introduce process pressure into the low pressure side.

- (1) Close the equalizer valve.
- (2) Gradually open the low pressure side stop valve.

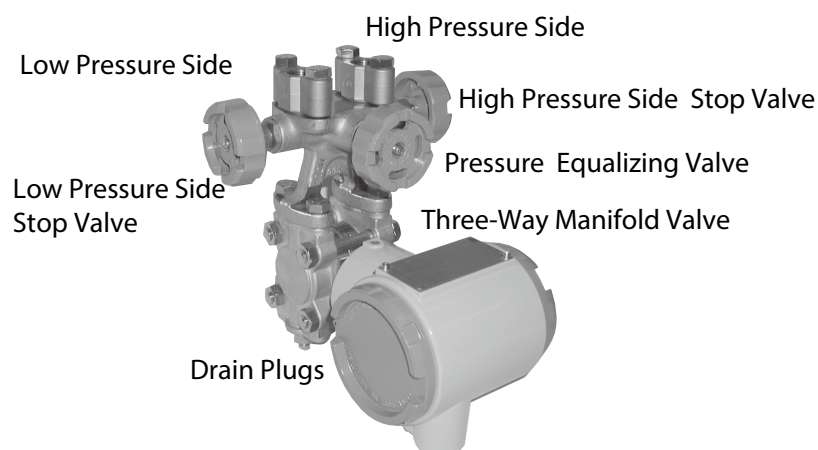

(ii) Checking measured values

- Using the communicator, check the measured values.
- After checking, disconnect the communication cable, attach the device's case cover, and switch the process to normal operation.
- If the analog signal output, the displayed values, etc., do not match the process conditions, recheck the setting range and the like. If this does not solve the problem, carry out the troubleshooting in Chapter 4, or contact us.
- If the measurement output and display do not stabilize, refer to Chapter 4 and adjust the damping time constant.

Note: Transmitter responsiveness varies with each model. When replacing an instrument, adjust the damping time constant as necessary so that it is appropriate for the instrumentation loop.

(iii) Cautions following confirmation of readings

After checking the measured values, confirm that the device's case cover is securely closed. If it is not securely closed, rainwater and the like can enter the device and cause damage to the terminals, electronics modules, etc., located inside.

(3) Stopping Operation

(i) Stopping operation of the device

To stop operation of the device, carry out the following procedure.

◆ Procedure ◆

- (1) Turn off the power to the device.
- (2) Operate the valves of the three-way manifold valve in the following order.
 - (1) Close the low pressure side stop valve.
 - (2) Open the equalizer valve.
 - (3) Close the high pressure side stop valve.

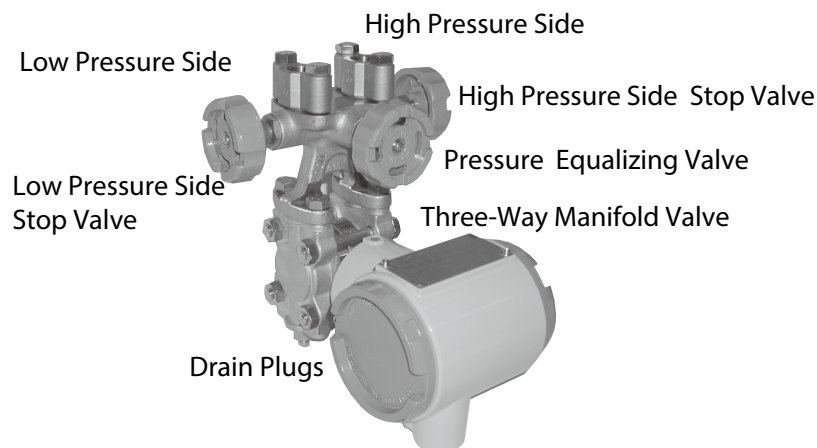

- (3) Close the high and low pressure side master valves (see Figures 2-30 and 2-31).

(ii) Cautions for stopping device operation











- If operation will be stopped for a long period of time, remove the process fluid from inside the connecting pipes and the pressure-receiving part of the device. The process fluid might, for example, adhere to the surface of the diaphragm and impede measurement when operation resumes.
- Leave the equalizer valve open. If it is left closed, output of other than zero can occur when the power is turned on to restart operation.

Chapter 4 : Instrument maintenance and troubleshooting

This chapter describes this device's data storage, assembly and disassembly, output checking, calibration methods, and countermeasures if problems occur.

4-1 : Assembly and Disassembly of this Device

4-1-1 : Cautions During Assembly and Disassembly

 Warning	
	When detaching this product from the process for maintenance and the like, clear vents and drains in order to remove residual pressure and residues in the measurement target. In addition, when clearing vents and drains, check the direction in which material will come out in order to avoid any contact with the human body. There is a danger of scalding and other harmful health effects. If the measured fluid is harmful to the human body, take safety measures such as wearing goggles or a mask so that it does not adhere to the skin or the eyes, become inhaled, etc.
	Particular care must be exercised due to the fact that, for pressure-resistant, explosion-proof transmitters, the pressure-resistant, explosion-proof performance specifications may be lost as a result of corrosion, deformation, or scratching of the case or case cover, or damage to the threaded portions or connecting surfaces.
	Do not open the case cover in the hazardous areas described in 4-1-2 when the device is powered up.
	For pressure-resistant, explosion-proof model transmitters, the pressure-resistant, explosion-proof performance specifications are ensured by locking the case cover. Fasten the case cover completely, and be sure to lock it.
	Replace damaged seal gaskets. If this product is operated in a damaged state, it will not be possible to ensure sufficient performance of the seals, and there is a danger that the measured fluid will spurt out, possibly resulting in scalding and other harmful health effects.
	Use genuine parts as replacements. In particular, for gaskets, adapter flanges, and the like, parts from other manufactures may in some cases fit into place, but they cannot ensure pressure resistance and airtightness. The result may be leakage of the measured fluid, with possible harmful effects on human health.
	Be sufficiently careful of residues from measured fluids which are left behind in the product. If materials which affect the human body are contained in these residues, harmful effects on human health could result. When performing maintenance on a product which has been uninstalled, first clean the pressure-receiving parts adequately.
	If evidence of corrosion is observed in pressure-bearing parts such as through bolts, nuts, and pressure-release rings, replace them. Parts whose pressure-resistance has decreased can break and thus are dangerous. There is also a risk of physical injuries such as bruises and lacerations caused by broken parts.
	When loosening through bolts and nuts to remove the device, hold the drain ring assembly to prevent it from falling off. If it falls because sufficient care is not taken, it can cause injuries or product damage.

4-1-2 : Attaching and Detaching the Case Cover

This product has a locking structure. When detaching the case cover, first loosen the lock using a standard hexagonal wrench. When attaching the case cover, first screw on the case cover tightly, and then fasten the lock using the hexagonal wrench.

When attaching the case cover, first screw on the case cover tightly, and then fasten the lock using the hexagonal wrench. For information on how to install the case cover, see section 2-4-1 (7).

Caution



After detaching the case cover, be careful that dust, rainwater, etc., do not enter the inside of the transmitter case.

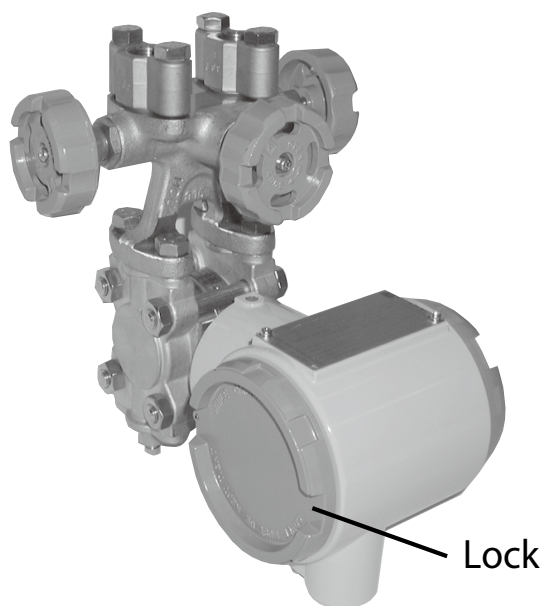

Figure 4-1 Locking the Device

4-1-3 : Attaching and Detaching the Main Unit Cover

(1) Detachment

When detaching the main unit cover, remove the four sets of nuts and bolts shown in the diagram below.

 Caution
 After detaching the main unit cover, be careful not to scratch the diaphragm.

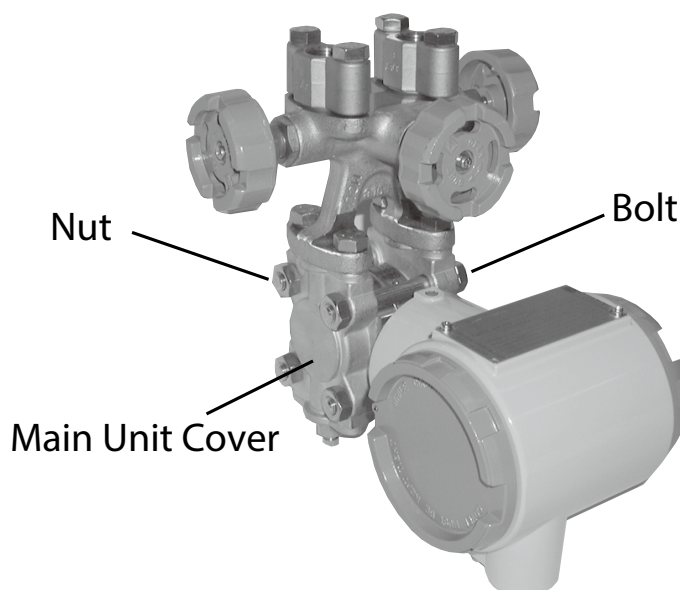

Figure 4-2 Nuts and Bolts Fastening the Main Unit Cover

(2) Attachment

When attaching the main unit cover, fasten the bolts to the appropriate tightening torque below. If the seal gaskets are damaged, replace them with new ones.

Table 4-1 Cover Bolt and Nut Tightening Torques (N·m)

Bolt/Nut	Bolt/Nut Material	Bolt and Nut Tightening Torques (N·m)	
		When Using New Gaskets	When Reusing Gaskets
M10	Carbon steel	22±2	17±1
	SUS304	15±2	10±1

4-1-4 : Cleaning the Device

(1) Introduction

In order to maintain the performance specifications of the transmitter, it is necessary to thoroughly clean the transmitter and pipes. If, for example, sediment accumulates in the pressure chamber of the transmitter, it can cause measurement errors.

(2) Cleaning the Main Unit

(i) Procedure

- (1) Remove the bolts and nuts, and detach the main unit cover.
- (2) Clean the diaphragm, the inside of the main unit cover, etc., using a soft brush and solvent. When doing so, be careful not to deform or scratch the diaphragm.
- (3) During re-assembly, replace cover gaskets with new ones as necessary.
- (4) Fasten bolts and nuts to the prescribed fastening torque (Table 4-1).

When measuring and stopping operation of a device in a cold area in which there is a risk that water (etc.) may freeze, remove the water from the main unit. Loosen the drain plugs.

4-2 : Calibration of the Setting Range and Output Signal

This section describes calibration work which is performed at our company and at designated service stations. Since precise reference input devices and measuring instruments are necessary, this is not work that will typically be carried out by users, but it is described in case it absolutely must be performed.

As shown below, there are two types of calibration.

- Setting range calibration (input calibration) using a reference input device
- Output signal calibration

4-2-1 : Setting Range Calibration Using a Reference Input Device

(1) Preparation

The method for calibrating the lower range value (LRV) and upper range value (URV) of the setting range by inputting a reference pressure into the device is described below. First calibrate the lower range value, and then the upper range value.

(2) Device to Use

For this calibration, have the following devices available. The required performance specifications for each device are provided for reference. It is desirable for the uncertainty of the measuring device to be at least four times the accuracy of the transmitter to be calibrated.

- Standard pressure generator: One that can generate pressures in the measurement range of the device
Accuracy: $\pm 0.05\%$ F.S. or $\pm 0.1\%$ setting.
- Power supply: 24 V DC
- Precision resistor: $250\ \Omega \pm 0.005\%$
- Voltmeter: 10 V DC range $\pm 0.02\% + 1$ digit
- Communicator: Model CFS100

(3) Caution

The accuracy of this device after calibration depends on the performance specifications of the device used here.

(4) Calibration Conditions

Perform real pressure calibration under the following environmental conditions.

- Perform calibration in a windless test chamber. If there is a wind, pressure will be applied to the pressure-receiving part on the side that is open to the atmosphere, which may exert an effect on calibration accuracy.
- Standard operating temperature of 23 °C, humidity of 65%. Provided that there is no rapid fluctuation, there will not be any significant effects even if the temperature is in the 15 to 35 °C range, or if humidity is in the 45 to 75% range.

(5) Wiring and Piping During Calibration

In general, the following wiring and piping should be employed.

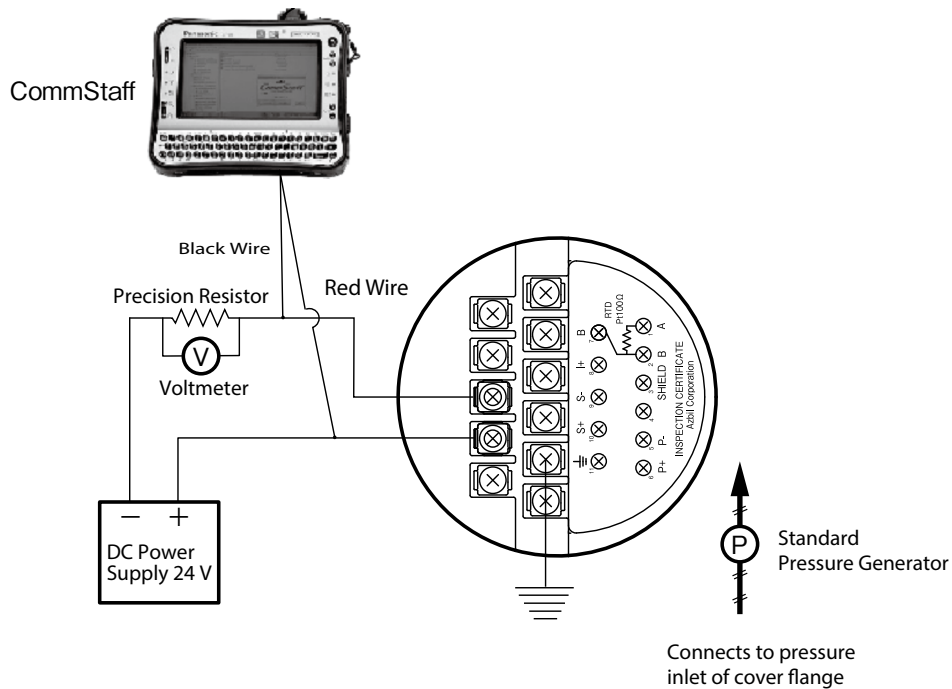

Figure 4-3 Wiring and piping during Calibration

(6) Checking the Setting Range

See the operation manuals for the respective communicators.

Field Communication Software CommStaff Model: CFS100 Instruction Manual
(Smart Transmitter Model JTD720A Edition)

CM2-CFS100-2007

(7) Measurement Range Calibration Procedure

See the operation manuals for the respective communicators.

Field Communication Software CommStaff Model: CFS100 Instruction Manual
(Smart Transmitter Model JTD720A Edition)

CM2-CFS100-2007

•

4-2-2 : Calibrating the differential pressure sensor

This section explains the general procedures for transmitter maintenance.

4-2-2-1 Calibrating the differential pressure

For the JTD720A series smart multivariable transmitters, the measurement range must be calibrated at two points, namely the LRV (input value at 0% output) and URV (input value at 100% output).

This calibration is done when calibrating actual pressures using a standard pressure transmitter.

CAUTION: If the transmitter's process is controlled automatically, this reset action could put the operation at risk by causing output fluctuation. Before resetting, make sure that the control loop for the process is manually controlled.

Select [Device Setup] → [Diag/Service] → [Calibration] → [Correct Input].

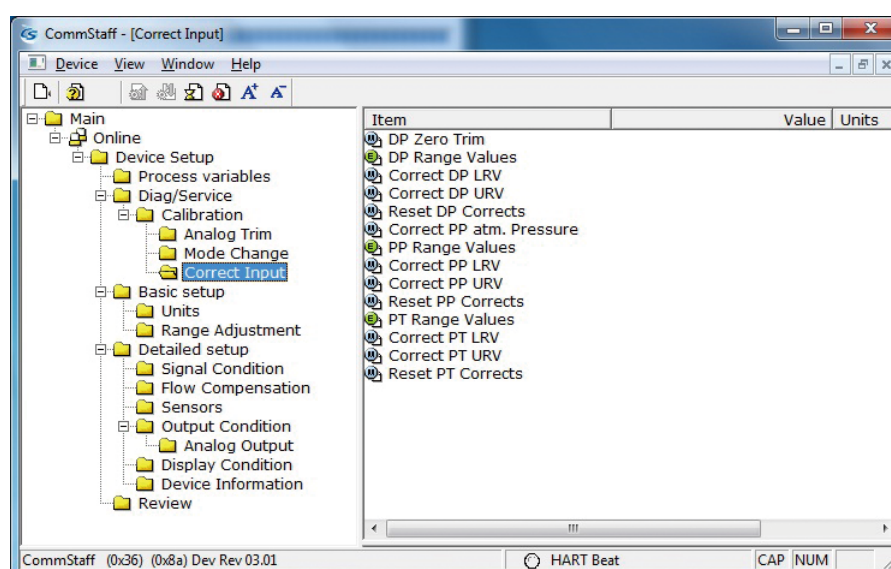

- First, double-click DP Range Values, and check the values for DP LRV and the DP URV. If a change is necessary, change the values.
- To calibrate the DP LRV value, double-click Correct DP LRV. To calibrate the DP URV value, double-click Correct Input DP URV. When changing both the DP LRV and the DP URV, be sure to do the DP LRV first.
- A warning that the loop should be switched from automatic control to manual mode is displayed (WARN - Loop should be removed from automatic control). After switching to manual mode, click OK.
- A warning that this operation will affect the sensor calibration (WARN-This will affect sensor calibration) is displayed. To proceed, click [OK].
- The question “Set DP Mode. OK?” appears in order to confirm configuration of the differential pressure mode. To set the mode, click [OK].
- Either “Apply DP LRV pressure” or “Apply DP URV pressure” is displayed. If the value of the standard pressure generator is equal to DP LRV or DP URV, click OK.

- “Press OK when pressure is stable” is displayed. After confirming that input pressure has stabilized, click OK.
- If the calibration succeeds, [Correct DP LRV succeeded] or [Correct DP URV succeeded] will be displayed. Click [OK].
- After clearing the differential pressure mode, the “Note - Loop may be returned to automatic control” message is displayed to notify you that you can now switch back to automatic control. Click OK.

4-2-2-2 Calibrating when pressure is equalized

The calibration method when the pressure is equalized is as follows.

CAUTION: If the transmitter's process is controlled automatically, this reset action could put the operation at risk by causing output fluctuation. Before resetting, make sure that the control loop for the process is manually controlled.

Select [Device Setup] → [Diag/Service] → [Calibration] → [Correct Input].

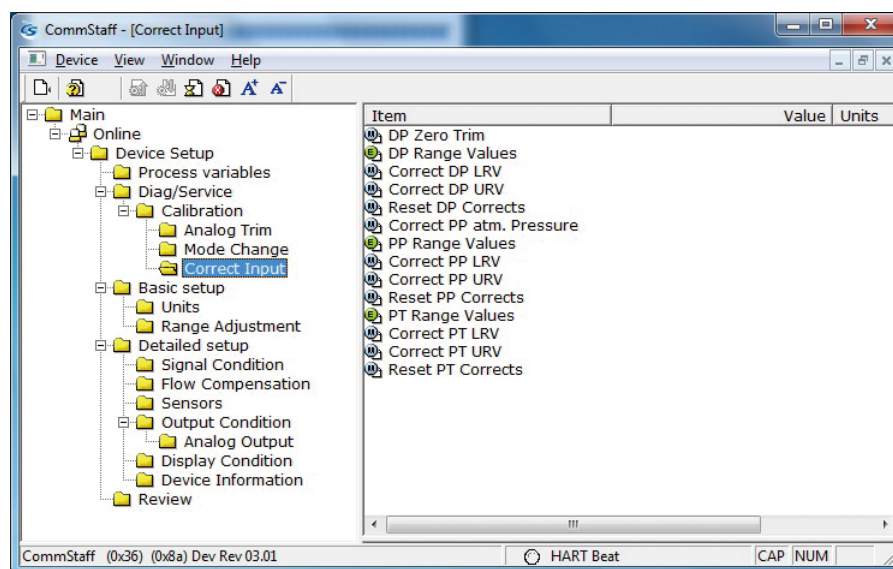

- Double-click DP Zero Trim.
- A warning that the loop should be switched from automatic control to manual mode is displayed (WARN - Loop should be removed from automatic control). After switching to manual mode, click OK.
- A warning that this operation will affect the sensor calibration (WARN-This will affect sensor calibration) is displayed. To proceed, click [OK].
- The question “Set DP Mode. OK?” appears in order to confirm configuration of the differential pressure mode. To set the mode, click [OK].
- When “Apply 0 input to sensor” is displayed and the differential pressure input is equalized, click [OK].
- If the calibration succeeds, [DP zero trim succeeded] will be displayed. Click [OK].
- After clearing the differential pressure mode, the “Note - Loop may be returned to automatic control” message is displayed to notify you that you can now switch back to automatic control. Click OK.

4-2-3 : Calibrating the static pressure sensor

4-2-3-1 Calibrating the atmospheric pressure

Calibrate the pressure to set the pressure on the transmitter as 1 atmospheric pressure (101.3 kPa abs.)

CAUTION: If the transmitter's process is controlled automatically, this reset action could put the operation at risk by causing output fluctuation. Before resetting, make sure that the control loop for the process is manually controlled.

Select [Device Setup] → [Diag/Service] → [Calibration] → [Correct Input].

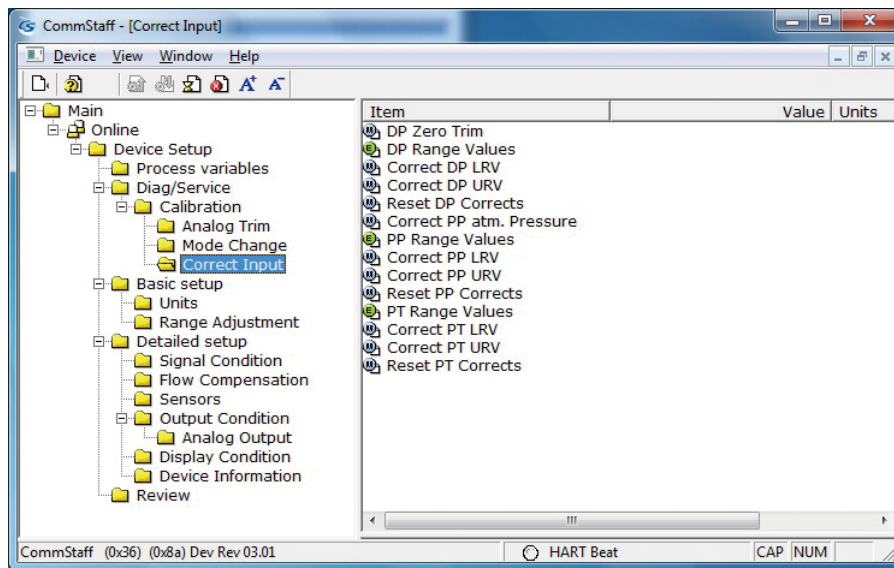

- Double-click PP atm. Pressure.
- A warning that the loop should be switched from automatic control to manual mode is displayed (WARN - Loop should be removed from automatic control). After switching to manual mode, click OK.
- A warning that this operation will affect the sensor calibration (WARN-This will affect sensor calibration) is displayed. To proceed, click [OK].
- The question “Set PP Mode. OK?” appears in order to confirm configuration of the pressure mode. To set the mode, click [OK].
- “Apply 0 input to sensor” is displayed. After input the atmospheric pressure, click OK.
- “Press OK when pressure is stable” is displayed. After confirming that input pressure has stabilized, click OK.
- If the calibration succeeds, [Correct PP atm. pressure succeeded] will be displayed. Click [OK].
- After clearing the pressure mode, the “Note - Loop may be returned to automatic control” message is displayed to notify you that you can now switch back to automatic control. Click OK.

4-2-3-2. Calibrating the pressure

CAUTION: If the transmitter's process is controlled automatically, this reset action could put the operation at risk by causing output fluctuation. Before resetting, make sure that the control loop for the process is manually controlled.

Select [Device Setup] → [Diag/Service] → [Calibration] → [Correct Input].

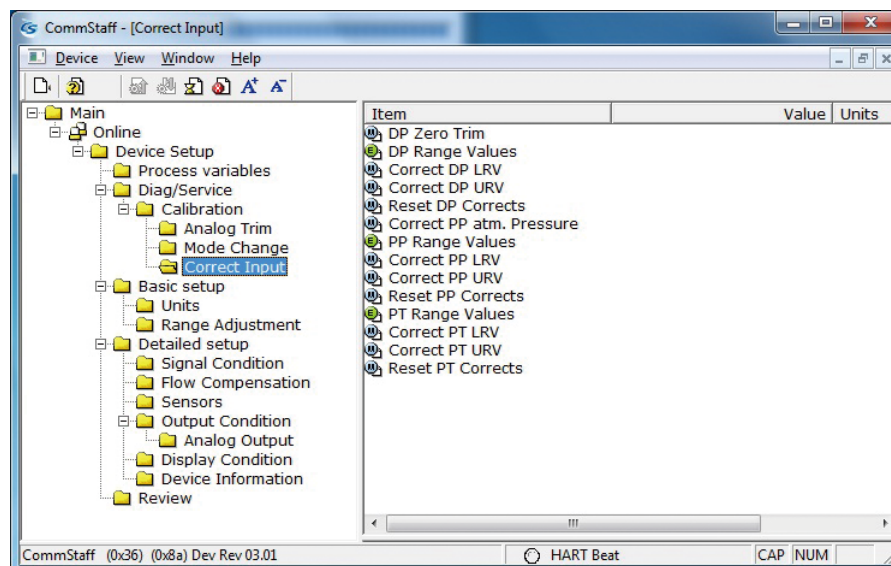

- First, double-click PP Range Values, and check the values for PP LRV and the PP URV. If a change is necessary, change the values.
- To calibrate the PP LRV value, double-click Correct Input PP LRV. To calibrate the PP URV value, double-click Correct Input PP URV. When changing both the PP LRV and the PP URV, be sure to do the PP LRV first.
- A warning that the loop should be switched from automatic control to manual mode is displayed (WARN - Loop should be removed from automatic control). After switching to manual mode, click OK.
- A warning that this operation will affect the sensor calibration (WARN-This will affect sensor calibration) is displayed. To proceed, click [OK].
- The question “Set PP Mode. OK?” appears in order to confirm configuration of the pressure mode. To set the mode, click [OK].
- Either “Apply PP LRV pressure” or “Apply PP URV pressure” is displayed. If the value of the standard pressure generator is equal to PP LRV or PP URV, click OK.
- “Press OK when pressure is stable” is displayed. After confirming that input pressure has stabilized, click OK.
- If the calibration succeeds, [Correct PP LRV succeeded] or [Correct PP URV succeeded] will be displayed. Click [OK].
- After clearing the pressure mode, the “Note - Loop may be returned to automatic control” message is displayed to notify you that you can now switch back to automatic control. Click OK.

4-2-4 : Calibrating a temperature sensor

CAUTION: If the transmitter's process is controlled automatically, this reset action could put the operation at risk by causing output fluctuation. Before resetting, make sure that the control loop for the process is manually controlled.

Select [Device Setup] → [Diag/Service] → [Calibration] → [Correct Input].

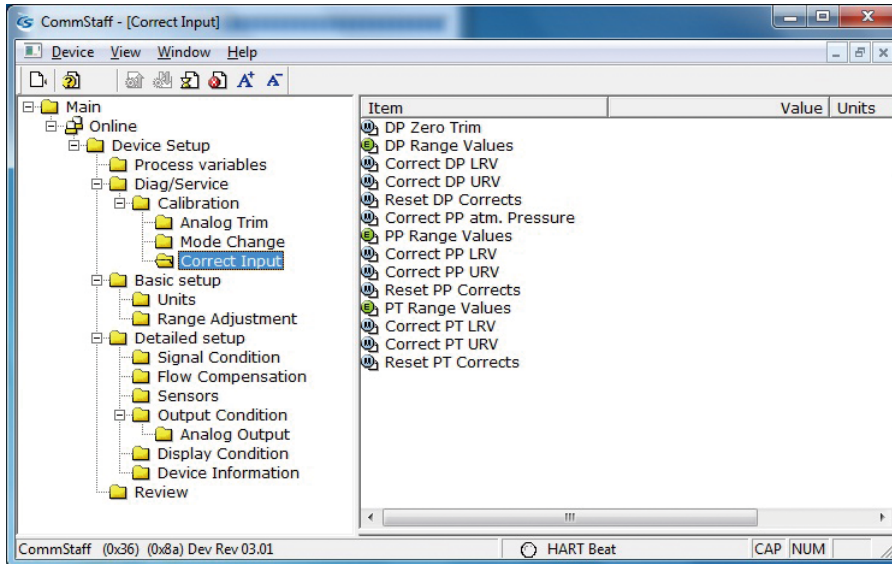

- First, double-click PT Range Values, and check the values for PT LRV and the PTURV. If a change is necessary, change the values.
- To calibrate the PT LRV value, double-click Correct Input PT LRV. To calibrate the PT URV value, double-click Correct Input PT URV. When changing both the PT LRV and the PT URV, be sure to do the PT LRV first.
- A warning that the loop should be switched from automatic control to manual mode is displayed (WARN - Loop should be removed from automatic control). After switching to manual mode, click OK.
- A warning that this operation will affect the sensor calibration (WARN-This will affect sensor calibration) is displayed. To proceed, click [OK].
- The question “Set PT Mode. OK?” appears in order to confirm configuration of the pressure mode. To set the mode, click [OK].
- Either “Apply PT LRV value” or “Apply PT URV value” is displayed. If the value of the reference input temperature is equal to PT LRV or PT URV, click OK.
- “Press OK when pressure is stable” is displayed. After confirming that reference input temperature has stabilized, click OK.
- If the calibration succeeds, [Correct PT LRV succeeded] or [Correct PT URV succeeded] will be displayed. Click [OK].
- After clearing the pressure mode, the “Note - Loop may be returned to automatic control” message is displayed to notify you that you can now switch back to automatic control. Click OK.

4-3 : Output Signal Calibration

(1) Preparation

In normal circumstances, output signal calibration (D/A converter adjustment) is not necessary and should not be done. If performing this operation cannot be avoided, have the following devices on hand.

(2) Required Equipment

- Precision ammeter: 0.03% FS
- Precision resistor: $250\ \Omega \pm 0.005\%$
- Communicator: Model CFS100

(3) Output Signal Calibration Procedure

See the operation manuals for the respective communicators.

Field Communication Software CommStaff Model: CFS100 Instruction Manual
(Smart Transmitter Model JTD720A Edition)

CM2-CFS100-2007

4-4 : Troubleshooting

4-4-1 : Checking this instrument

If the transmitter does not operate, or if it operates erroneously, check the items in Tables 4-4 and 4-5. If the situation does not improve even after performing these checks, stop using the device immediately, turn off the power, and contact one of our branch offices, sales offices, or distributors.

Table 4-2 Troubleshooting

Phenomenon	Countermeasures
Nothing is displayed on the display	<ul style="list-style-type: none"> • Confirm that the correct power supply voltage is being applied. • Confirm that the power supply is connected.
Output is fixed at 0	<ul style="list-style-type: none"> • Confirm that the device's settings are correct. • Confirm that the flow rate is not in the low-flow cutoff range. • Confirm that there are no clogs in the connecting pipes. • Confirm that the manifold valve, stop valves, etc., are in the correct open and closed states.
Output is shifted	<ul style="list-style-type: none"> • Confirm that fluid is not leaking from the pipes. • Confirm that fluid is not flowing in reverse. • Confirm that the respective directions of the high pressure side and low pressure side connections are correct. • Confirm that the transmitter is not tilted significantly.

In addition to the above, check the following.

- Self-diagnostics results using the communicator (Table 4-5)
- Whether there are leaks in the pipe connectors
- Whether the product side bolt fasteners are loose
- Whether any pipes are loose or disconnected
- Whether the power supply voltage, load resistance, etc., are in accordance with the specifications
- Whether the pressure and temperature are in accordance with the specifications
- Whether there are any strong sources of magnetism or electrical noise nearby

4-4-2 : Checking Self-diagnostic Messages

You can check self-diagnostic messages by clicking the Status icon in the below or “Device status” in the “Display” menu.

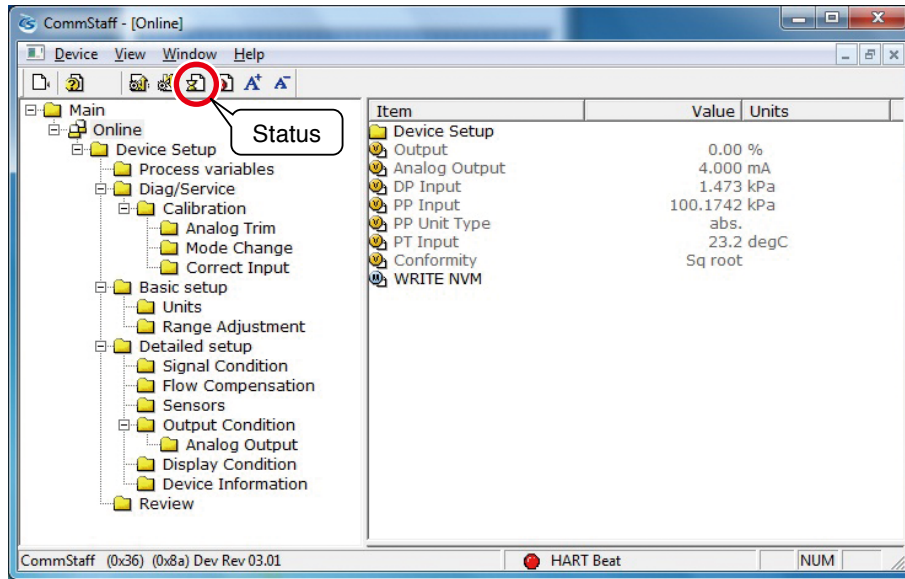

4-4-3 : Status Message

Status message	Meaning	Required action
Internal data inconsistency		
Invalid database	Configuration data and/or calibration data is invalid.	Tap [Exit] and try communicating again. Verify configuration data and recalibrate the device.
Critical failure		
Status 1-0	Unknown error	Contact appropriate personnel.
Chara. PROM Fault	PROM function fault	Invalid device characteristics data. Contact appropriate personnel.
Suspect Input	- Input data error - Problem with the process - Device error	Invalid sensor and/or electronics board. Contact appropriate personnel.
Status 1-3	Unknown error	Contact appropriate personnel.
NVM Fault	Electronic component failure	Bad electronics board. Contact appropriate personnel.
RAM Fault	Electronic component failure	Bad electronics board. Contact appropriate personnel.
ROM Fault	Electronic component failure	Bad electronics board. Contact appropriate personnel.
Status 1-7	Unknown error	Contact appropriate personnel.
Status 7-0	Unknown error	Contact appropriate personnel.
Status 7-1	Unknown error	Contact appropriate personnel.
PT Suspect Input	- Input data error - Problem with the process - Device error	Resistance thermometer wires may be down or connected incorrectly. If the problem persists, electronics board may be invalid. Contact appropriate personnel.
Status 7-3	Unknown error	Contact appropriate personnel.
Status 7-4	Unknown error	Contact appropriate personnel.
Status 7-5	Unknown error	Contact appropriate personnel.
Status 7-6	Unknown error	Contact appropriate personnel.
Status 7-7	Unknown error	Contact appropriate personnel.

Status message	Meaning	Required action
Non-critical status		
Excess sensor temp.	Meter body temperature is too high.	Relocate device to keep temperature within specification limits.
Excess DP Zero Correct	DP Zero correction factor is outside acceptable limits for accurate operation.	Check if the calibration value is suitable for the input pressure value. Recalibrate device.
Excess DP Span Correct	DP Span correction factor is outside acceptable limits for accurate operation.	Check if the calibration value is suitable for the input pressure value. Recalibrate device.
In Special Mode	Device is operating in DP mode, PP mode, PT mode, input mode and/or output mode.	Return to measuring mode to clear message.
DP Overload	The input pressure exceeds two times the upper range limit of the device. In such a case output is at the upper or lower limit.	Check PV value and decrease the differential pressure to within specifications.
Meter Body Fault	The input pressure exceeds two times The upper range limit of The device. Device error	Check PV value and decrease the differential pressure to within specifications.
DP Correct Reset	DP calibration data discarded.	Calibrate the zero point and span of the DP range.
Status 2-7	Unknown error	Contact appropriate personnel.
Status 3-0	Unknown error	Contact appropriate personnel.
Status 3-1	Unknown error	Contact appropriate personnel.
Status 3-2	Unknown error	Contact appropriate personnel.
Status 3-3	Unknown error	Contact appropriate personnel.
Status 3-4	Unknown error	Contact appropriate personnel.
Status 3-5	Unknown error	Contact appropriate personnel.
Status 3-6	Unknown error	Contact appropriate personnel.
Status 3-7	Unknown error	Contact appropriate personnel.
Status 4-0	Unknown error	Contact appropriate personnel.

Status message	Meaning	Required action
Non-critical status		
Excess PP Zero Correct	The PP Zero correction factor is outside the acceptable limits for accurate operation.	Check if the calibration value is suitable for the input pressure value. Recalibrate device.
Excess PP Span Correct	The PP Span correction factor is outside the acceptable limits for accurate operation.	Check if the calibration value is suitable for the input pressure value. Recalibrate device.
Status 4-3	Unknown error	Contact appropriate personnel.
PP Overload	- the Input pressure exceeds two times the upper range limit of the device. - Device error	Check PV value and decrease the static pressure to within specifications.
Status 4-5	Unknown error	Contact appropriate personnel.
PP Correct Reset	PP calibration data discarded.	Calibrate the zero point and span of the PP range.
Status 4-7	Unknown error	Contact appropriate personnel.
In DP Mode	The device is operating in differential pressure mode.	Exit DP Adjustment / DP Calibration screen to clear differential pressure mode.
In PP Mode	The device is operating in process pressure (static pressure) mode.	Exit PP Adjustment / PP Calibration screen to clear process pressure mode.
In PT Mode	The device is operating in process temperature mode.	Exit PT Adjustment / PT Calibration screen to clear process temperature mode.
Status 5-3	Unknown error	Contact appropriate personnel.
In DP Input Mode	The device is operating in differential pressure input mode.	Tap [Clear] to clear differential pressure input mode.
In PP Input Mode	The device is operating in process pressure (static pressure) input mode.	Tap [Clear] to clear process pressure (static pressure) input mode.
In PT Input Mode	The device is operating in process temperature input mode.	Tap [Clear] to clear process temperature input mode.
Status 5-7	Unknown error	Contact appropriate personnel.
Status 6-0	Unknown error	Contact appropriate personnel.
Status 6-1	Unknown error	Contact appropriate personnel.
Status 6-2	Unknown error	Contact appropriate personnel.
Status 6-3	Unknown error	Contact appropriate personnel.

Status message	Meaning	Required action
Non-critical status		
In Output Mode	The device is operating in output mode.	Tap [Clear output mode] to clear output mode.
In PP Output Mode	PV2 is operating in output mode.	Tap [Clear output mode] to clear process pressure output mode.
In PT Output Mode	PV3 is operating in output mode.	Tap [Clear output mode] to clear process temperature output mode.
Status 6-7	Unknown error	Contact appropriate personnel.
Status 8-0	Unknown error	Contact appropriate personnel.
Excess PT Zero Correct	PT Zero correction factor exceeds acceptable limits.	Check if the calibration value is suitable for the input value. Recalibrate device.
Excess PT Span Correct	PT Span correction factor exceeds acceptable limits.	Check if the calibration value is suitable for the input value. Recalibrate device.
Status 8-3	Unknown error	Contact appropriate personnel.
Out of PT Input	- process temperature Input is out of sensor range. - Device error	Temperature may exceed operating limits. Check process temperature. Or, bad resistance thermometer and/or electronics board. Contact appropriate personnel.
Status 8-5	Unknown error	Contact appropriate personnel.
PT Correct Reset	PT calibration data discarded.	Calibrate the zero point and span of the PT range.
Status 8-7	Unknown error	Contact appropriate personnel.
Status 9-0	Unknown error	Contact appropriate personnel.
Status 9-1	Unknown error	Contact appropriate personnel.
Status 9-2	Unknown error	Contact appropriate personnel.
Status 9-3	Unknown error	Contact appropriate personnel.
Status 9-4	Unknown error	Contact appropriate personnel.
Status 9-5	Unknown error	Contact appropriate personnel.
Status 9-6	Unknown error	Contact appropriate personnel.
Status 9-7	Unknown error	Contact appropriate personnel.

Terms and Conditions

We would like to express our appreciation for your purchase and use of Azbil Corporation's products.

You are required to acknowledge and agree upon the following terms and conditions for your purchase of Azbil Corporation's products (system products, field instruments, control valves, and control products), unless otherwise stated in any separate document, including, without limitation, estimation sheets, written agreements, catalogs, specifications and instruction manuals.

1. Warranty period and warranty scope

1.1 Warranty period

Azbil Corporation's products shall be warranted for one (1) year from the date of your purchase of the said products or the delivery of the said products to a place designated by you.

1.2 Warranty scope

In the event that Azbil Corporation's product has any failure attributable to azbil during the aforementioned warranty period, Azbil Corporation shall, without charge, deliver a replacement for the said product to the place where you purchased, or repair the said product and deliver it to the aforementioned place. Notwithstanding the foregoing, any failure falling under one of the following shall not be covered under this warranty:

- (1) Failure caused by your improper use of azbil product (noncompliance with conditions, environment of use, precautions, etc. set forth in catalogs, specifications, instruction manuals, etc.);
- (2) Failure caused for other reasons than Azbil Corporation's product;
- (3) Failure caused by any modification or repair made by any person other than Azbil Corporation or Azbil Corporation's subcontractors;
- (4) Failure caused by your use of Azbil Corporation's product in a manner not conforming to the intended usage of that product;
- (5) Failure that the state-of-the-art at the time of Azbil Corporation's shipment did not allow Azbil Corporation to predict; or
- (6) Failure that arose from any reason not attributable to Azbil Corporation, including, without limitation, acts of God, disasters, and actions taken by a third party.

Please note that the term "warranty" as used herein refers to equipment-only-warranty, and Azbil Corporation shall not be liable for any damages, including direct, indirect, special, incidental or consequential damages in connection with or arising out of Azbil Corporation's products.

2. Ascertainment of suitability

You are required to ascertain the suitability of Azbil Corporation's product in case of your use of the same with your machinery, equipment, etc. (hereinafter referred to as "Equipment") on your own responsibility, taking the following matters into consideration:

- (1) Regulations and standards or laws that your Equipment is to comply with.
- (2) Examples of application described in any documents provided by Azbil Corporation are for your reference purpose only, and you are required to check the functions and safety of your Equipment prior to your use.
- (3) Measures to be taken to secure the required level of the reliability and safety of your Equipment in your use

Although azbil is constantly making efforts to improve the quality and reliability of Azbil Corporation's products, there exists a possibility that parts and machinery may break down. You are required to provide your Equipment with safety design such as fool-proof design,*1 and fail-safe design*2 (anti-flame propagation design, etc.), whereby preventing any occurrence of physical injuries, fires, significant damage, and so forth. Furthermore, fault avoidance,*3 fault tolerance,*4 or the like should be incorporated so that the said Equipment can satisfy the level of reliability and safety required for your use.

*1. A design that is safe even if the user makes an error.

*2. A design that is safe even if the device fails.

*3. Avoidance of device failure by using highly reliable components, etc.

*4. The use of redundancy.

3. Precautions and restrictions on application

3.1 Restrictions on application

Please follow the table below for use in nuclear power or radiation-related equipment.

	Nuclear power quality*5 required	Nuclear power quality*5 not required
Within a radiation controlled area*6	Cannot be used (except for limit switches for nuclear power*7)	Cannot be used (except for limit switches for nuclear power*7)
Outside a radiation controlled area*6	Cannot be used (except for limit switches for nuclear power*7)	Can be used

*5. Nuclear power quality: compliance with JEAG 4121 required

*6. Radiation controlled area: an area governed by the requirements of article 3 of "Rules on the Prevention of Harm from Ionizing Radiation," article 2 2 4 of "Regulations on Installation and Operation of Nuclear Reactors for Practical Power Generation," article 4 of "Determining the Quantity, etc., of Radiation-Emitting Isotopes," etc.

*7. Limit switch for nuclear power: a limit switch designed, manufactured and sold according to IEEE 382 and JEAG 4121.

Any Azbil Corporation's products shall not be used for/with medical equipment.

The products are for industrial use. Do not allow general consumers to install or use any Azbil Corporation's product. However, azbil products can be incorporated into products used by general consumers. If you intend to use a product for that purpose, please contact one of our sales representatives.

3.2 Precautions on application

you are required to conduct a consultation with our sales representative and understand detail specifications, cautions for operation, and so forth by reference to catalogs, specifications, instruction manual, etc. in case that you intend to use azbil product for any purposes specified in (1) through (6) below. Moreover, you are required to provide your Equipment with fool-proof design, fail-safe design, anti-flame propagation design, fault avoidance, fault tolerance, and other kinds of protection/safety circuit design on your own responsibility to ensure reliability and safety, whereby preventing problems caused by failure or nonconformity.

- (1) For use under such conditions or in such environments as not stated in technical documents, including catalogs, specification, and instruction manuals
- (2) For use of specific purposes, such as:
 - * Nuclear energy/radiation related facilities
[When used outside a radiation controlled area and where nuclear power quality is not required]
[When the limit switch for nuclear power is used]
 - * Machinery or equipment for space/sea bottom
 - * Transportation equipment
[Railway, aircraft, vessels, vehicle equipment, etc.]
 - * Antidisaster/crime-prevention equipment
 - * Burning appliances
 - * Electrothermal equipment
 - * Amusement facilities
 - * Facilities/applications associated directly with billing
- (3) Supply systems such as electricity/gas/water supply systems, large-scale communication systems, and traffic/air traffic control systems requiring high reliability
- (4) Facilities that are to comply with regulations of governmental/public agencies or specific industries
- (5) Machinery or equipment that may affect human lives, human bodies or properties
- (6) Other machinery or equipment equivalent to those set forth in items (1) to (5) above which require high reliability and safety

4. Precautions against long-term use

Use of Azbil Corporation's products, including switches, which contain electronic components, over a prolonged period may degrade insulation or increase contact-resistance and may result in heat generation or any other similar problem causing such product or switch to develop safety hazards such as smoking, ignition, and electrification. Although acceleration of the above situation varies depending on the conditions or environment of use of the products, you are required not to use any Azbil Corporation's products for a period exceeding ten (10) years unless otherwise stated in specifications or instruction manuals.

5. Recommendation for renewal

Mechanical components, such as relays and switches, used for Azbil Corporation's products will reach the end of their life due to wear by repetitious open/close operations.

In addition, electronic components such as electrolytic capacitors will reach the end of their life due to aged deterioration based on the conditions or environment in which such electronic components are used. Although acceleration of the above situation varies depending on the conditions or environment of use, the number of open/close operations of relays, etc. as prescribed in specifications or instruction manuals, or depending on the design margin of your machine or equipment, you are required to renew any Azbil Corporation's products every 5 to 10 years unless otherwise specified in specifications or instruction manuals. System products, field instruments (sensors such as pressure/flow/level sensors, regulating valves, etc.) will reach the end of their life due to aged deterioration of parts. For those parts that will reach the end of their life due to aged deterioration, recommended replacement cycles are prescribed. You are required to replace parts based on such recommended replacement cycles.

6. Other precautions

Prior to your use of Azbil Corporation's products, you are required to understand and comply with specifications (e.g., conditions and environment of use), precautions, warnings/cautions/notices as set forth in the technical documents prepared for individual Azbil Corporation's products, such as catalogs, specifications, and instruction manuals to ensure the quality, reliability, and safety of those products.

7. Changes to specifications

Please note that the descriptions contained in any documents provided by azbil are subject to change without notice for improvement or for any other reason. For inquires or information on specifications as you may need to check, please contact our branch offices or sales offices, or your local sales agents.

8. Discontinuance of the supply of products/parts

Please note that the production of any Azbil Corporation's product may be discontinued without notice. After manufacturing is discontinued, we may not be able to provide replacement products even within the warranty period.

For repairable products, we will, in principle, undertake repairs for five (5) years after the discontinuance of those products. In some cases, however, we cannot undertake such repairs for reasons, such as the absence of repair parts. For system products, field instruments, we may not be able to undertake parts replacement for similar reasons.

9. Scope of services

Prices of Azbil Corporation's products do not include any charges for services such as engineer dispatch service. Accordingly, a separate fee will be charged in any of the following cases:

- (1) Installation, adjustment, guidance, and attendance at a test run
- (2) Maintenance, inspection, adjustment, and repair
- (3) Technical guidance and technical education
- (4) Special test or special inspection of a product under the conditions specified by you

Please note that we cannot provide any services as set forth above in a nuclear energy controlled area (radiation controlled area) or at a place where the level of exposure to radiation is equivalent to that in a nuclear energy controlled area.

Document Number:	CM2-DST720-2001
Document Name:	Smart Multivariable Transmitter Model JTD720A User's Manual
Date:	1st edition: Nov. 2004 5th edition: Oct. 2024
Issued/Edited by:	Azbil Corporation

Azbil Corporation