

# Smart Valve Positioner 700 Series with HART Communication Protocol

Model AVP701/702

## User's Manual



Azbil Corporation

## Notice

---

---

- Make sure that this manual is delivered to the user of this product.
  - It is prohibited to copy or reprint this manual in whole or in part without permission.
  - The contents of this manual are subject to change without notice.
  - Although Azbil took all possible measures to ensure the accuracy of this manual, contact us if you find any errors or missing information.
  - Note that we cannot be held responsible for the results of customer operation.
  - HART® is a registered trademark of the FieldComm Group.
- 
-

# Introduction

Thank you for purchasing our AVP702 Smart Valve Positioner. The AVP702 (called “the device” below) is a smart valve positioner that can be connected to the 4 to 20 mA loop.

The auto setup function makes it easy to set up the valve.

All adjustments and setup can be performed from the HART communication. The Local User Interface (LUI), which consists of the LCD (liquid crystal display) and operation buttons, facilitates monitoring of input signals, valve opening, pressure display, and other items as well as basic adjustments.

In addition, the built-in pressure sensor can be used to measure the supply air pressure and output air pressure. As a result, the device can not only perform self-diagnostics but can also be combined with the control valve maintenance support system called “Valstaff” in order to monitor the characteristics, operating status, and other data of the control valve, helping to improve the maintenance efficiency of control valves. This instruction manual describes how to handle the device. Read this manual to make full use of the features of this product.

## Scope of this manual and related documents

This document describes the functions and method of installation and adjustment of this device. For details on HART communication, refer to *Smart Valve Positioner 700 Series with HART Communication Protocol Model AVP701/702 HART Communication Manual* (No. CM2-AVP702-2002\*).

For details on the control valve diagnostic items, refer to the “Smart Valve Positioner 700 Series Control Valve Diagnostic Function Manual” (No. CM2-AVP700-2003\*).

\* If you need the above documents, please contact one of our sales representatives.

# Safety precautions

## ■ Symbols

The purpose of the safety precautions listed here is to ensure the user uses the product safely and correctly, to prevent harm to the user and other people and damage to property.

Make sure to obey the safety precautions.

Many different symbols are used in this manual.

Their appearances and meanings are as described below. Thoroughly understand the explanation before starting to read the main text.



### **Warning**

Wrong handling may cause the death or severe injury of the user.



### **Cautions**





Wrong handling may cause a minor injury to the user or damage to equipment.













## ■ Sample symbols

	This symbol indicates “warnings” and “cautions” that you must pay attention to when handling the device.
	This symbol indicates “prohibited” actions that must not be taken.
	This symbol indicates “instructions” for the action that must be taken.





## Precautions for safe work

 <b>Warning</b>	
	Do not perform wiring with wet hands or while the device is energized. This may lead to electric shock. Turn the power off before starting the work and work with dry hands or use gloves.
	Follow the work procedure defined in the explosion protection guidelines of countries when performing the power distribution work in an explosion-proof area.
	For devices equipped with the pressure-resistant, explosion-proof specifications, open/close the explosionproof enclosure and the cover according to "Chapter 7 Notes on the Explosion-Proof".

 <b>Cautions</b>	
	Do not get on the installed device or use it as a step stool. This is dangerous because the device may tip over.
	Do not touch the device during operation without reason. This is dangerous because the surface may be hot or cold depending on the usage environment.
	Be careful not to touch the edge of the cover or the screw threads of the main unit when opening the cover of the terminal box. You may be injured by these parts.
	Use a DC power supply with overload protection. Overload may cause smoke or fire.
	If a tool or other item touches the glass part of the display, it may break, leading to an injury. Be careful. Wear safety glasses during work.
	This product is heavy. Be careful where you step and wear safety shoes during work.
	Do not touch the feedback lever or other moving part while the device is operating. You may be injured by getting your hand or other body part caught in them.
	Properly use the power supply based on the specifications. Inputting a different power supply may damage the device.
	Use gloves and other protective equipment during work in a hot, cold, or other severe environment.
	Do not move the device close to a magnet or magnetic driver. The control valve may operate.
	Apply the correct supply air pressure in accordance with the specification of the device. The overpressure may cause abnormal actions of the control valve or damage to the pressure gauge.

## Precaution for disposal of Electrical and Electronic Equipment

<p><b>Disposal of Electrical and Electronic Equipment (for Environmental Protection)</b>            This is an industrial product subject to the WEEE Directive.            Do not dispose of electrical and electronic equipment in the same way as household waste.            Old products contain valuable raw materials and must be returned to an authorized collection point for correct disposal or recycling.</p>	 
--	--

# Unpacking, Verification, and Storage of Product

## Unpacking

This device is precision measuring equipment. Carefully handle it to prevent accidents or damage.

After unpacking, check that the items below are included.

- The device
- Feedback lever and hexagon socket bolts x 2
- (4-mm) hexagon wrench x 1 (for feedback lever) (Included only when the device is shipped alone.)
- Regulator (optional)
- Mounting plate set (optional)
- Pressure-resistant packing cable adapter and pressure-resistant elbow (option for explosion-proof specifications)
- Instruction manual (this document) (Included if specified at the time of purchase.)
- Extension lever and hexagon socket bolts x 2 (optional)

## Specifications check

The specifications are shown on the nameplate of the main unit. Check that the specifications are the same as what you specified. In particular, confirm the following points.

- Tag No. (TAG No.)
- Model (MODEL)
- Work No. (PROD.)
- Input current range (INPUT)
- Supply air pressure (SUPPLY)
- Explosion protection certification seal (for explosion-proof specifications)

 <b>WARNING</b>	
	When using the device in an explosion-proof area, be sure to select the model that satisfies the necessary explosion-proof requirements. Non-explosion-proof products cannot be used in an explosion-proof area.

## Contact

For inquiries about this device, please contact us.

When contacting us, let us know the model number and production number.

## Storage

When storing the device after purchase, obey the following precautions.

- When storing the device before it has been used
  1. Store the device as packed at shipment.
  2. Store the device at an indoor location with little vibration or shocks and at normal temperature and humidity (about 25°C, 65%).
- When storing the device after it has been used
  1. Tightly secure the terminal box cover and block the conduit connection port with tape to prevent humidity intrusion.
  2. Block the three pneumatic piping connection ports (SUP , OUT1 and OUT2) with tape to prevent humidity and dust intrusion.
  3. Pack the device in the same way as at shipment.
  4. Store the device at an indoor location with little vibration or shocks where it will not be exposed to rain or water and at normal temperature and humidity (about 25°C, 65%).

# Table of Contents

<b>Chapter 1</b>	<b>Structure of the 700 Series Control System</b>	<b>1-1</b>
1-1	System Configuration	1-1
1-2	System Configuration without Motion Transmission	1-2
1-3	System Configuration with Motion Transmission	1-2
1-4	Structure of the Device and Description of Each Part	1-3
1-4-1	Structure of the Device	1-3
1-4-2	Structure of Terminal Box	1-5
1-4-3	Display on the Local User Interface (LUI)	1-7
<b>Chapter 2</b>	<b>Installation of the 700 Series</b>	<b>2-1</b>
2-1	Usage Conditions	2-1
2-2	Selection Criteria for Installation Location	2-2
2-2-1	Selection Criteria for Installation Location	2-2
2-2-2	Criteria for instrumentation air	2-2
2-3	Installation Procedure	2-4
2-3-1	Mounting the 700 Series onto the Actuator	2-4
2-3-2	Pneumatic Piping Connection	2-11
2-3-3	Electrical Wiring Connection	2-14
2-3-4	Input Signals and Travel Transmission Power	2-16
2-3-5	Cables	2-17
2-4	Cable gland and flameproof universal elbow for TIIS Flameproof apparatus	2-19
<b>Chapter 3</b>	<b>Operation of the 700 Series</b>	<b>3-1</b>
3-1	Local User Interface (LUI)	3-1
3-2	Adjustment before Operation	3-5
3-2-1	Auto Setup	3-5
3-2-2	Zero Span Adjustment	3-9
3-2-3	Supply Bypass	3-12
3-2-4	Control Parameters	3-13
3-2-5	Password	3-15
3-3	Starting Operation	3-16
3-3-1	Preoperation Check	3-16
<b>Chapter 4</b>	<b>Operation with HART Communication</b>	<b>4-1</b>
4-1	Operation with HART Communication	4-1
4-2	Setup and Adjustment of Device	4-2
4-2-1	Process Variables	4-2
4-2-2	Auto Setup	4-3
4-2-3	Input Range	4-5
4-2-4	Valve System	4-5
4-2-5	Control Configuration	4-6
4-2-6	Input Characterization	4-8
4-2-7	Travel Cutoff	4-8
4-2-8	Units	4-9
4-2-9	Travel Calibration	4-10
4-2-10	Input Calibration	4-12
4-2-11	Pressure Sensor Adjustment	4-12
4-2-12	Simulation	4-12
4-2-13	Adjustment of EPM Drive Signal (Pneumatic Modules)	4-13
4-2-14	Restore factory settings	4-13
4-2-15	Operator Action Records	4-13
4-2-16	Real Time Clock	4-13
4-2-17	Password	4-13

4-2-18 Device Information . . . . .	4-14
4-2-19 Option . . . . .	4-16
4-2-20 Diagnostic Messages . . . . .	4-17
4-2-21 Control Valve Diagnostic Messages . . . . .	4-19
<b>Chapter 5 Troubleshooting . . . . .</b>	<b>5-1</b>
5-1 Troubleshooting . . . . .	5-2
5-1-1 The Device Does Not Operate. (There Is No Output Air Pressure.) . . . . .	5-2
5-1-2 The Control Valve Operates Abnormally (There Is Output Air Pressure.) . . . . .	5-2
5-1-3 Failure to communicate with the communicator . . . . .	5-2
5-1-4 Adjustment Procedure When Hunting Occurs . . . . .	5-3
5-1-5 Auto Setup Failure . . . . .	5-4
5-2 Description of Messages. . . . .	5-5
<b>Chapter 6 Maintenance . . . . .</b>	<b>6-1</b>
6-1 A/M Switch . . . . .	6-2
6-2 Replacement of Filter and Maintenance of Flow Restriction. . . . .	6-4
6-3 Cleaning the Flapper. . . . .	6-5
6-4 Adjusting the Pilot Relay . . . . .	6-6
6-5 Insulation Resistance Test . . . . .	6-7
6-6 Adjustment Procedure When Using the Device with the Booster Relay Attached . . . . .	6-8
6-7 List of Default Values for Internal Data . . . . .	6-9
6-8 Internal Block Diagram of the 700 Series . . . . .	6-10
6-9 Resale Parts . . . . .	6-11
6-9-1 Procedure to Change Switch Block . . . . .	6-15
6-9-2 Procedure to Change Pilot Relay . . . . .	6-16
<b>Chapter 7 Notes on the Explosion-Proof 700 Series . . . . .</b>	<b>7-1</b>
7-1 TIIS Flameproof Model . . . . .	7-2
7-2 IECEx Flameproof and Dust Ignition Protection . . . . .	7-3
7-3 FM Explosionproof / Dust Ignition Protection . . . . .	7-5
7-4 FM Intrinsically safe (ic) and Nonincendive . . . . .	7-6
7-5 FMC Explosionproof / Dust Ignition Protection . . . . .	7-11
7-6 CCC Flameproof / Dust Ignition Protection. . . . .	7-12
7-7 KCs Flameproof . . . . .	7-14
7-8 INMETRO Flameproof / Dust Ignition Protection . . . . .	7-15
7-9 EAC Flameproof . . . . .	7-17
7-10 ATEX Intrinsic Safety and Dust Ignition Protection. . . . .	7-19
7-11 IECEx Intrinsic Safety and Dust Ignition Protection . . . . .	7-20
7-12 CCC Intrinsic Safety and Dust Ignition Protection . . . . .	7-21
7-13 CNS Flameproof . . . . .	7-24
7-14 CNS Intrinsic Safety and Dust Ignition Protection. . . . .	7-25
7-15 NEPSI Intrinsic Safety and Dust Ignition Protection . . . . .	7-26
7-16 NEPSI Flameproof . . . . .	7-28
<b>Appendix A LUI Display Example . . . . .</b>	<b>A-1</b>
<b>Appendix B Menu List. . . . .</b>	<b>B-1</b>
<b>Appendix C Specification . . . . .</b>	<b>C-1</b>
<b>Appendix D Model Selection . . . . .</b>	<b>D-1</b>
<b>Appendix E Outline Dimensional Drawing . . . . .</b>	<b>E-1</b>

# Chapter 1 Structure of the 700 Series Control System

This chapter describes the device configuration of the control system that uses the device.

- Description of the configuration of the input/output system in the device
- Description of the structure of the main unit of the device and the name and function of each part

## 1-1 System Configuration

This device is a smart valve positioner that can be connected to the 4–20 mA DC signal lines of the controller output. It makes various adjustments using electricity, so the relationship between input signals and control valve travel can be set to any desired value. In addition, by connecting the device using four lines, the control valve travel is transmitted to the host monitoring system as a 4–20 mA DC analog signal. (Only the AVP701 model supports valve travel transmission.)

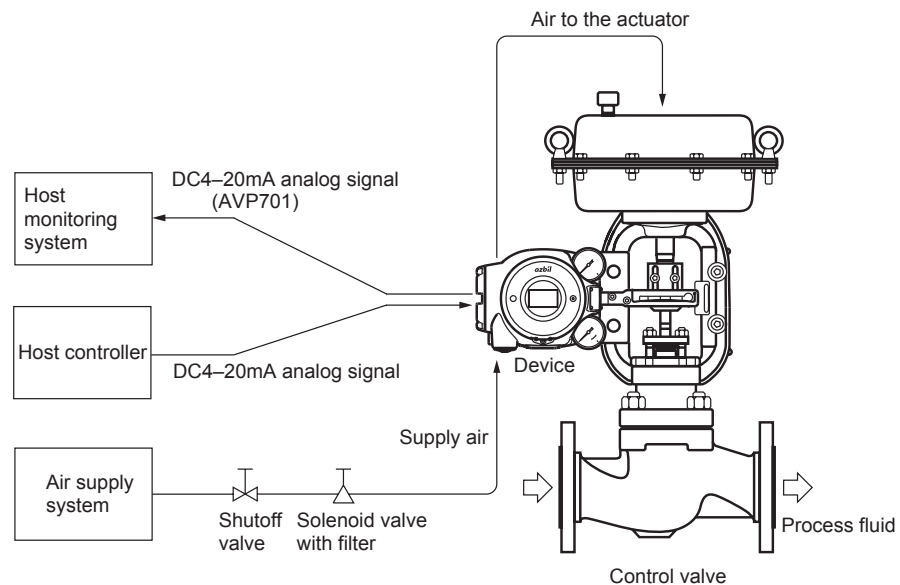

Figure1-1 Concept Diagram of the 700 Series Control System

## 1-2 System Configuration without Motion Transmission

This shows the configuration for a system that does not use the motion transmission function of this device (model AVP702).

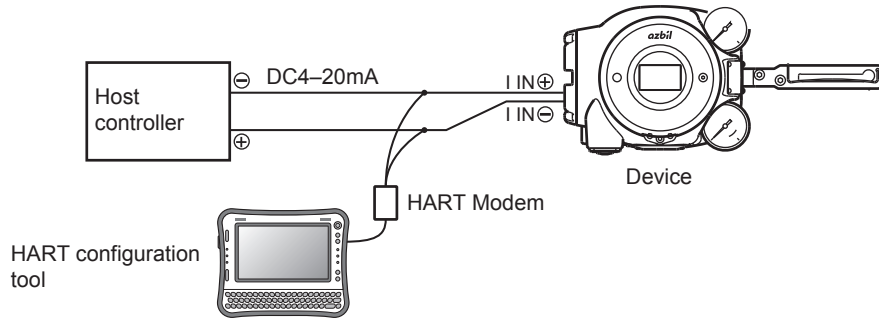

Figure1-2 System Configuration without Motion Transmission (Model AVP702)

## 1-3 System Configuration with Motion Transmission

This device (model AVP701) has a function for motion transmission of the control valve.

To output the travel signal to the host monitoring device using analog values, configure the system with motion transmission. Normally, the travel from fully closed to fully open are output as 4-20 mA DC.

This shows an example of a system configuration for outputting valve travels detected with this device as 4-20 mA DC analog signals.

With this system configuration, analog signals are output directly to the higher-order host monitoring system from this device.

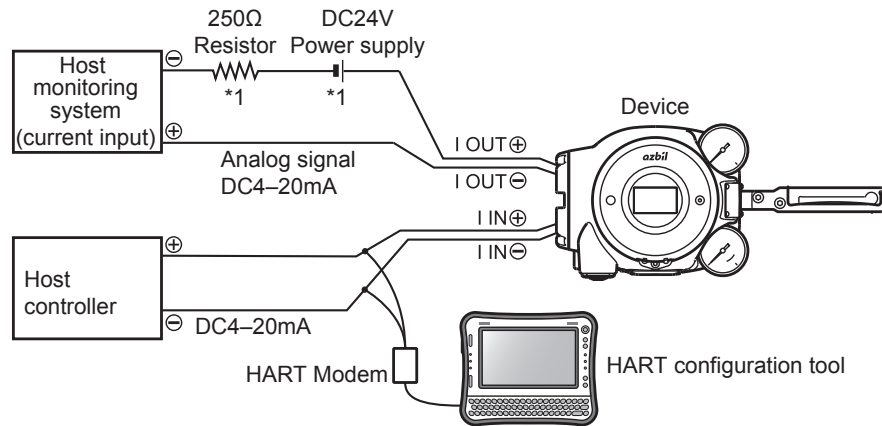

\*1: For the detailed information of the power supply and resistor, please refer to the figure 2-18 of 2-3-4 Input Signals and Travel Transmission Power

Figure1-3 System Configuration with Motion Transmission (Model AVP701)

## 1-4 Structure of the Device and Description of Each Part

### 1-4-1 Structure of the Device

#### 1) Major components

The structure of the main unit of the device is shown in the figure below.

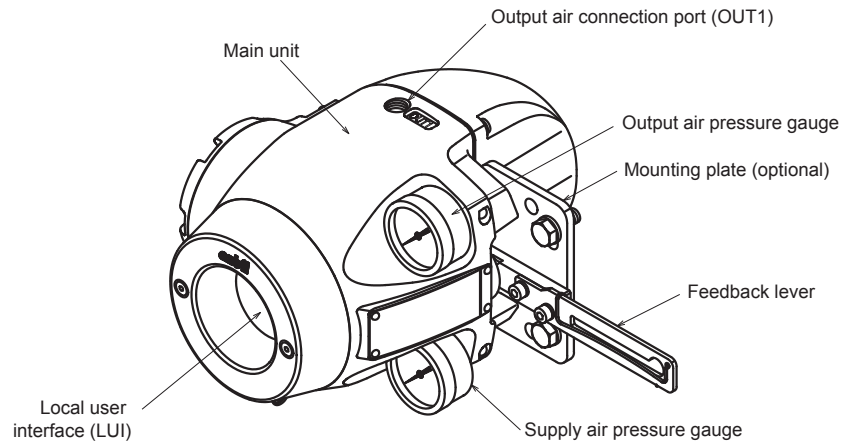

Figure1-4 Structure of the Device (Upper)

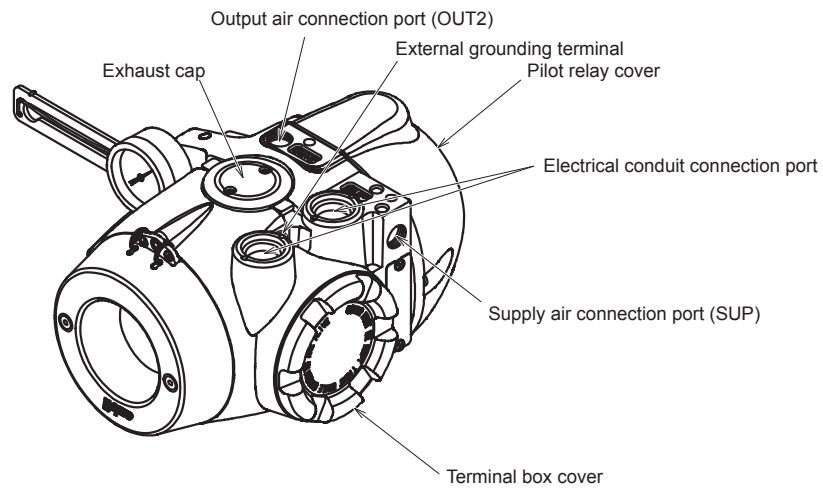

Figure1-5 Structure of the Device (Lower)

## 2) Name and description of each part

The table below describes each part.

Table 1-1 Description of Each Part

Name	Description
Main unit	- Houses electronic circuits, an electro-pneumatic transducer (EPM), a position sensor (VTD), and a pressure sensor.
Pilot relay cover	- Cover of the pilot relay that amplifies the air signal from the EPM (electro-pneumatic transducer) and transduces it into the air signal sent to the actuator. - When you must adjust the balance pressure to switch between the pilot relay for the single-acting actuator and the pilot relay for the double-acting actuator, remove this cover.
Auto/Manual (A/M) switch	- This switch is used to switch how the output air between the auto operation status and the manual operation status is controlled. This switch is built into the pilot relay. This switch can be seen by removing the pilot relay cover.
Feedback lever	- Extracts and transmits the movement of the control valve lift to the VTD (position sensor).
Local user interface (LUI)	- The LUI allows you to adjust the zero span, perform auto setup, and manually operate the device with the LCD (liquid crystal display) and operation buttons without using the communicator.
Supply air pressure gauge	- Indicates the pressure of supply air.
Output air pressure gauge	- Indicates the pressure of output air.
Supply air connection port (SUP)	- Supply air is input to this port. - "SUP" is displayed at this port.
Output air connection port (OUT1)	- Output air is sent out of this port to the actuator. - "OUT1" is displayed at this port.
Output air connection port (OUT2)	- Output air is sent out of this port to the actuator. - This port is blocked with a blind plug in the single-acting actuator. - OUT2 is displayed at the output port for the double-acting actuator.
Mounting plate (optional)	- The mounting plate is used to mount the device onto the actuator. - The shape of the mounting plate differs depending on the specifications (actuator model).



## 1-4-2 Structure of Terminal Box

### 1) Major components

This contains the input signal (controller output) terminal, output signal (motion transmission) terminal, and internal ground terminal.

The structure of the terminal box is as shown below.

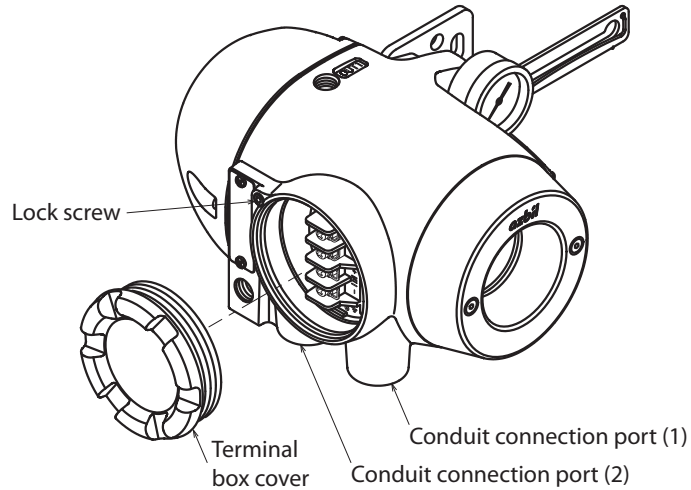

Figure1-6 Structure of Terminal Box

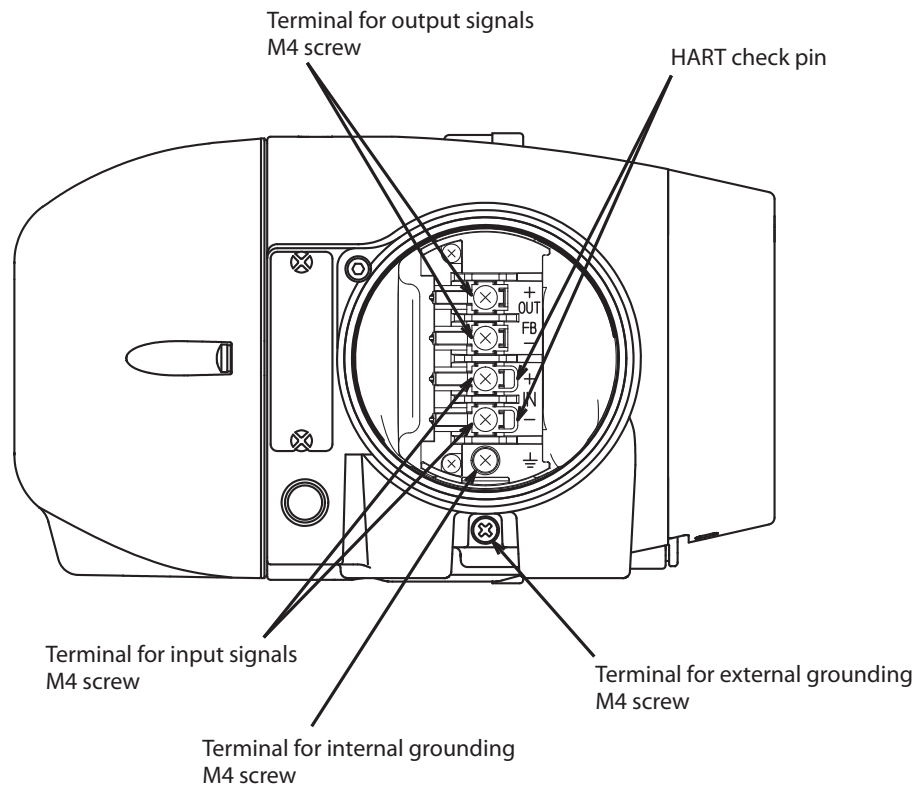

Figure1-7 Terminal Block in the Terminal Box

## 2) Name and description of each part

The table below describes each part of the terminal box.

Table 1-2 Description of Each Part

Name	Description
Terminal box cover	- Lid of terminal box. - This cover has a pressure-resistant explosion-proof structure.
Lock screw	- Used to secure the terminal box cover.
Terminal for input signals	- Shown as IN. - Connects the signal cable from the host controller.
Terminal for output signals	- Shown as OUT. - Connects the signal cable for motion transmission. - The AVP702 model (without motion transmission) does not have the terminal screws.
Internal grounding terminal	- Internal terminal for grounding. The cable for grounding is connected to this terminal.
Conduit connection port (1)	- Service entrance for a cable.
Conduit connection port (2)	- Service entrance for a cable. - This entrance is normally blocked with a blind plug.
Check pin for HART communication	- By connecting the connection hook for the setting device communication cable to this pin, it is possible to communicate with this device.

### **Warning**



When using a pressure-resistant explosion-proof model in a dangerous place, be sure to use the specified cable adapter for pressure-resistant packing for the conduit connection port. Securely close the terminal box cover all the way. Then, rotate the lock screw counterclockwise to secure the terminal box cover.

### **Handling Precautions:**

Ground either the external or internal grounding terminal according to the specifications. Be careful not to ground the device at two points.

### 1-4-3 Display on the Local User Interface (LUI)

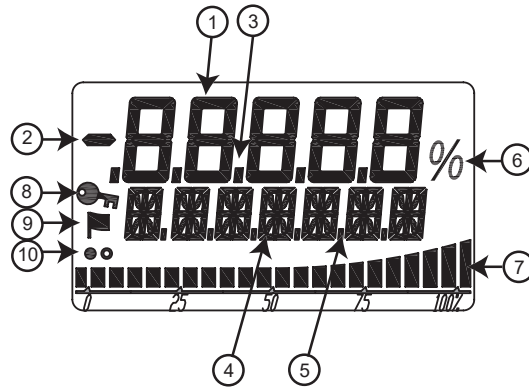

Figure1-8 Segments on the LCD

Table 1-3 Description of Each Part

No.	Displayed element	Main display
(1)	7 segments (5 digits)	Displays the main numerical values such as the specified opening.
(2)	Minus sign	Displays the sign for the 7-segment number.
(3)	Decimal point (five places)	Displays the decimal point for the 7-segment number.
(4)	16 segments (7 digits)	Displays the unit, status, or other data.
(5)	Dot (6 places)	Displays the 16-segment auxiliary display, separator, or other data.
(6)	Percentage	Displays %.
(7)	Bar graph (22 bars)	Displays the bar graph in percentage at a set point, etc.
(8)	Key mark	On: LUI operation is unavailable. Off: LUI operation is available. Blinking: LUI is in operation.
(9)	Flag mark	When the self-diagnostic alarm is activated, the key mark is displayed. For detailed information of the alarms, please refer to the status monitor of page 3-4.
(10)	Display refresh mark	Display during operation White and black circles alternately blink.

For a display example, refer to "LUI Display List" in Appendix A.

#### **!** Handling Precautions:

The LUI buttons may not respond well near an electromagnetic inductor (such as a large transformer or high-frequency furnace).

Remove sand, dust, and other foreign objects from the rubber parts of the operation buttons before operating the LUI. Operating the LUI with foreign objects on it may damage the rubber parts.

Do not pull the rubber parts of the operation buttons. This may deteriorate the sealability, possibly causing malfunction.



# Chapter 2 Installation of the 700 Series

This chapter describes the usage conditions, installation, piping, and wiring of the device.

## 2-1 Usage Conditions

The device must be installed in the location, which satisfies the following conditions.

Also, the device must be used in accordance with its specification.

Table 2-1 Range of Usage Conditions

		Units	Basic operating conditions	Normal operating conditions	Marginal operating conditions	Transportation conditions
Operating temperature range	General model	°C	23 ± 2	-40 to +80	-40 to +80	-40 to +70
	TIIS flameproof model	°C	23 ± 2	-20 to +55	-20 to +55	-40 to +70
	IECEX/FM/FMC/CCC/KCs flameproof model	°C	23 ± 2	-30 to +75	-30 to +75	-40 to +70
	FM Intrinsically Safe (ic) and Nonincendive	°C	23 ± 2	-24 to +75	-24 to +75	-40 to +70
	ATEX/IECEX intrinsically safe model	°C	23 ± 2	-40 to +60	-40 to +60	-40 to +70
	LUI	°C	23 ± 2	0 to 50	-40 to +80	-40 to +70
Input current		mA	4 to 20	3.84 to 21.6	0 to 3.84 <sup>Note 5</sup> 21.6 to 24	—
Vibration	Amplitude <sup>Note 1</sup>	mm <sub>p-p</sub>	0	15/(5 to 8 Hz)	15/(5 to 10 Hz)	15/(5 to 10 Hz)
	Acceleration <sup>Note 1 Note 2</sup>	m/s <sup>2</sup>	0	20/(8 to 400 Hz)	40/(10 to 400 Hz)	40/(10 to 400 Hz)
Friction of applied valve		%	3 to 20	3 to 20	0 to 3 20 to 100	—
Supply air pressure Ps (140 kPa ≤ Ps ≤ 700 kPa)		kPa	Ps ± 1%	140 to 700	0 to 710	—
Installation orientation <sup>Note 3</sup>		°	±1 <sup>Note 4</sup>	±180	±180	±180
Humidity range		%RH	50 ± 10	5 to 100	5 to 100	5 to 100

Each operating condition is defined as follows.

- Basic operating condition: Range in which the accuracy is guaranteed
- Normal operating condition: Range in which the positioner normally operates
- Marginal operating condition: Range in which performance is not guaranteed but the device can be without being permanently damaged
- Transportation condition: Environment condition range in which the non-operating device is not permanently damaged during transportation

Note 1: Vibration conditions when the positioner cover is positioned at the center front.

Note 2: The pressure gauge is not applied.

Note 3: The slope characteristics are not included.

Note 4: The status where the drive shaft of the direct-acting actuator is perpendicular to the ground and that is used as the reference.

Note 5: In the range of 3.5 mA to 3.84 mA, HART communication is possible though the operation of the positioner is not guaranteed. (The output air pressure assumes that the power is cut. The pressure sensor value is not guaranteed.)

## 2-2 Selection Criteria for Installation Location

The device is designed to withstand severe conditions, but the installation location should be selected according to the criteria described below to maximize performance.

### 2-2-1 Selection Criteria for Installation Location

Install the device in a location that satisfies all of the following conditions.

- Operating temperature range that conforms to the explosion protection rules
- Relative humidity: 5 to 100%RH
- Ambient temperature change rate:  $\pm 20^{\circ}\text{C/hr}$  or slower
- Electromagnetic induction: 400 A/m or less (Avoid places near a large transducer, high-frequency furnace, or other such equipment.)
- Do not use a transceiver near the device.
- Vibration:  $20 \text{ m/s}^2$  (5 to 400 Hz) or less  
(The vibration conditions defined for the device are the vibrations at the positioner part.)

### 2-2-2 Criteria for instrumentation air

The device employs a nozzle flapper structure in the electropneumatic transduction section. If instrumentation air is contaminated (includes oil, water, or other substance), the positioner function of the device may not function properly or an irrecoverable failure may occur. Therefore, the quality of instrumentation air supplied to the device is defined as follows.

- Solid material : No particles with a diameter larger than  $3 \mu\text{m}$ .
- Oil : Less than 1 ppm.
- Supply air humidity : The dew point temperature is at least  $10^{\circ}\text{C}$  lower than that of the device.

(This criterion is based on Japanese Industrial Standards JIS C 1805-1(2001).)

Select a compressor and main line or terminal-installation type compressed air purifier by referring to the above specifications.

#### (1) Compressed air purifier for the main line

Select a compressed air purifier for the main line, such as a main line filter or micro-alescer, to satisfy the above specifications.

Domestic compressed air purifier manufacturers of Japan: SMC Corporation and CKD Corporation

#### (2) Compressed air purifier to be installed on the terminal

If an air purifier cannot be installed on the main line due to installation of a control valve or for other reasons, use an compressed air purifier that can be installed on the terminal in order to satisfy the above specifications.

**<Example devices>**

- Products from SMC Corporation

Mist Separator AM150 or AM250 Series

(Filtering level: 0.3  $\mu\text{m}$ , Secondary oil mist concentration: 1.0  $\text{mg}/\text{m}^3$ )

- CKD Corporation

Oil mist filter

M1000 or M3000 Series

Mantle S Type (Filtering level: 0.3  $\mu\text{m}$ , Remaining oil: 1.0  $\text{mg}/\text{m}^3$ )

**! Handling Precautions:**

Select a compressed air purifier with specifications suited to the usage conditions. Even when you install the above oil removal equipment, it is necessary to properly inspect and maintain the air circuit section for long-term stable operation. Install the oil removal equipment before use and perform periodic inspection and maintenance.

The warranty is void if the device fails because the quality of the above instrumentation air was not sufficient.

## 2-3 Installation Procedure

### 2-3-1 Mounting the 700 Series onto the Actuator

The device is a smart valve positioner for use with a control valve that uses a direct-acting or rotary actuator. The main unit of the device weighs approximately 4.2 kg. The basic mounting procedure is the same as that for conventional electropneumatic positioners.

#### Cautions



Be careful not to get injured by sharp parts such as the edge of the main unit or actuator or screw threads during mounting.

The type of mounting plate, mounting method, and mounting procedure differ depending on the actuator model to be mounted in the device.

If the device is not properly mounted, not only will the device not be able to operate at its true performance but it may be damaged or fail. Pay attention to the following points.



- The mounting plate and its accessories differ depending on the specifications (actuator model). Be sure to use the appropriate mounting plate and accessories for the actuator to be mounted.
- When installing the control valve, ensure as much surrounding space as possible and put the device in the correct orientation taking maintainability (such as piping, wiring, and adjustment) into consideration.
- Deliver the device to the installation location in the packaged state if possible.
- Do not apply excessive force to the feedback lever during mounting.
- Do not bend the feedback pin.
- Do not block the exhaust port located underneath.
- Install the device so that the electrical conduit connection port does not face upward.
- Securely tighten bolts.
- If the pressure regulator with filter is installed with the device, install with the drain of the pressure regulator with filter facing downward. If the pressure regulator with filter cannot be attached vertically (with the drain facing downward), install it separated from the AVP with the proper orientation.
- In order to avoid the possibility of rainwater entering the pressure gauge, install the gauge such that it does not face upward or downward. In addition, the pressure gauge has a rainwater drain on its underside, so install the gauge with this hole facing downward.
- If you install this device with the LCD facing upwards, use the LCD cover and pressure gauge elbows as necessary, depending on the circumstances. For details, refer to 6) below, "Installing the device with the LCD facing upwards."



## 1) Mounting the feedback lever

Assemble the feedback lever from the front of the main unit of the device using the two included hexagon socket bolts.

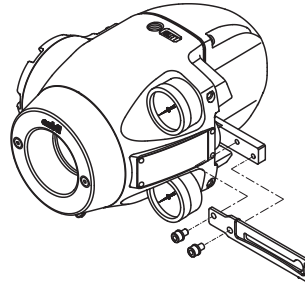

Figure 2-1 Mounting Procedure for Feedback Lever

Assemble the extension lever as shown in the figure below if necessary.

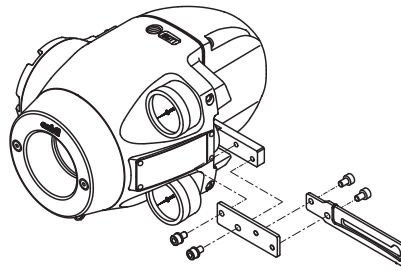

Figure 2-2 Mounting Procedure for Extension Lever

## 2) Mounting example

A typical mounting method is shown in the figure below. If your actuator is not shown in the figure below, refer to the assembly diagram included with the device.

**[Direct-Acting Actuator HA2 to 4, PSA1 to 4, 6, VA1 to 6 from Azbil Corporation]**

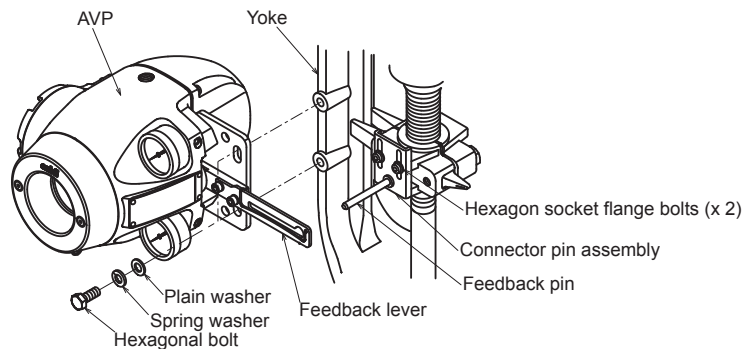

Figure 2-3 Mounting Procedure for Direct-Acting Actuator HA2 to 4, PSA1 to 4, 6, VA1 to 6 from Azbil Corporation

**[RSA1, 2, VR3 actuator from Azbil Corporation]**

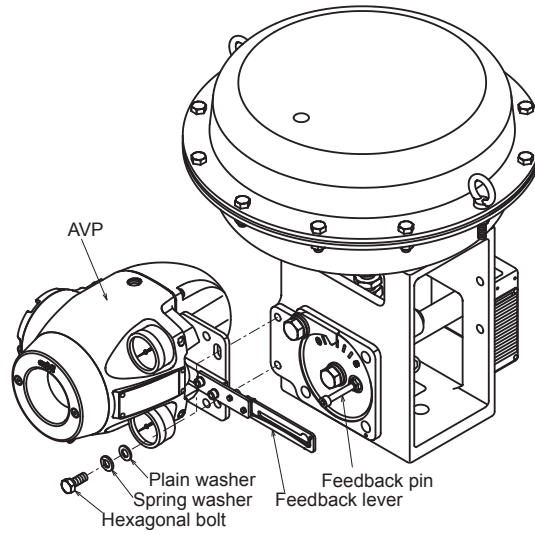

Figure 2-4 Mounting Procedure for RSA1, 2, VR3 Actuator from Azbil Corporation

**[Example of double-acting rotary cylinder actuator]**

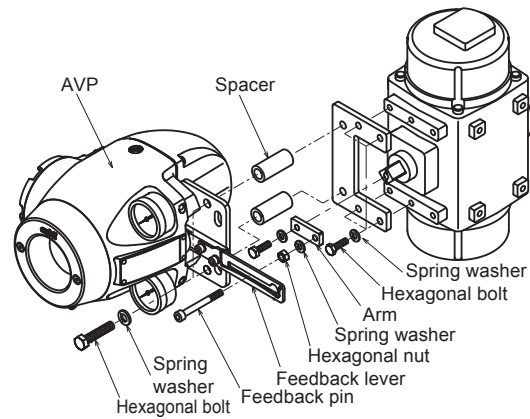

Figure 2-5 Mounting Procedure for Double-Acting Rotary Cylinder Actuator

3) Mounting procedure

The procedure for mounting the feedback lever onto the actuator is shown below.

Step	Work
1	Tightly secure the mounting plate by inserting hexagonal bolts (M8×20) with spring washers into the (two) screw holes at the rear of the device.
2	Tightly secure the device (mounting plate) onto the mounting seat of the actuator by using bolts and washers. At this time, insert the actuator feedback pin into the slotted hole of the feedback lever in the device.

#### 4) Connection of feedback pin and feedback lever (1)

There are several points to be careful of when connecting the feedback lever to the device and the actuator feedback pin. Connect correctly.

- Only a pin with a diameter of 6 mm can be used.
- Insert the pin between the guide and the spring.

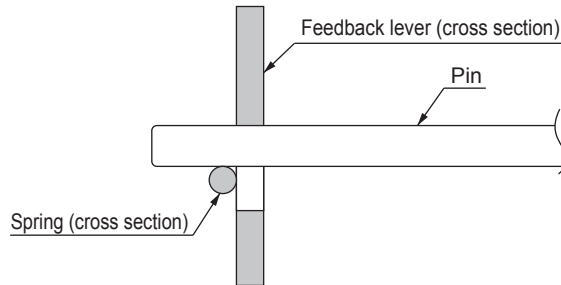

Figure 2-6 Connection of Feedback Lever and Feedback Pin

- Make the feedback lever perpendicular to the pin when viewed from the above.

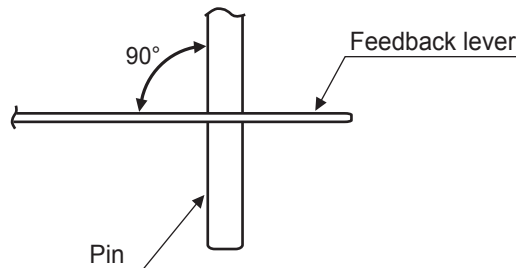

Figure 2-7 Angle between Feedback Lever and Pin

- Mount the lever so that it is horizontal when opened by 50%.
- The allowable rotation angle of the feedback lever is horizontal  $\pm 30^\circ$ . If the angle exceeds  $\pm 30^\circ$ , the self-diagnostic function detects Valve Travel Detector Out of Range and the device will not operate normally. (The accuracy is guaranteed when the rotation angle is between  $\pm 4^\circ$  and  $\pm 20^\circ$ .)

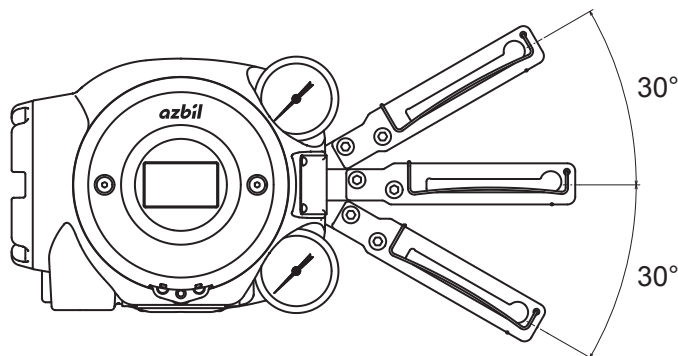

Figure 2-8 Operation Angle of Feedback Lever

- When assembling the lever onto a rotary cylinder so that the shaft of the rotary cylinder is positioned between the feedback pin and the 700 Series as shown in the figure below, select Rotary/90° (for 90°) or Rotary/other (for angles other than 90°) as the Actuator Type according to the rotation angle.

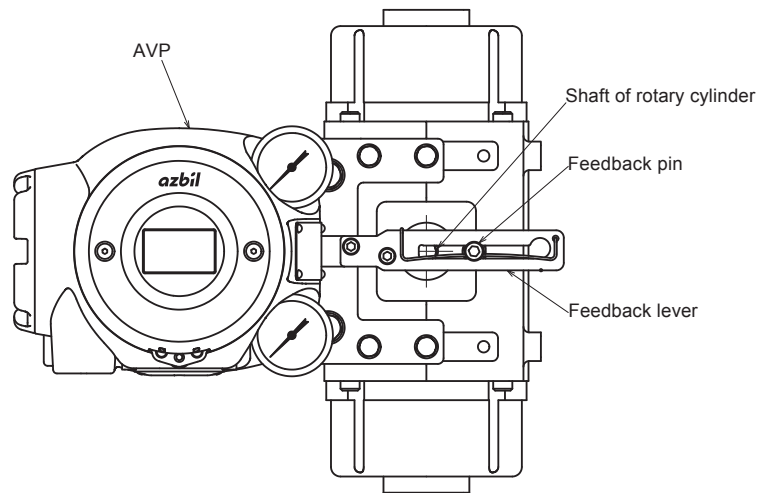

Figure 2-9 Connection of the Rotary Cylinder to the Feedback Pin and Feedback Lever

- When the rotary cylinder is large and the lever is assembled so that the feedback pin is positioned between the 700 Series and the shaft of the rotary cylinder as shown in the figure below, select Rotary (sub)/90° (for 90°) or Rotary (sub)/other (for angles other than 90°) as the Actuator Type according to the rotation angle.

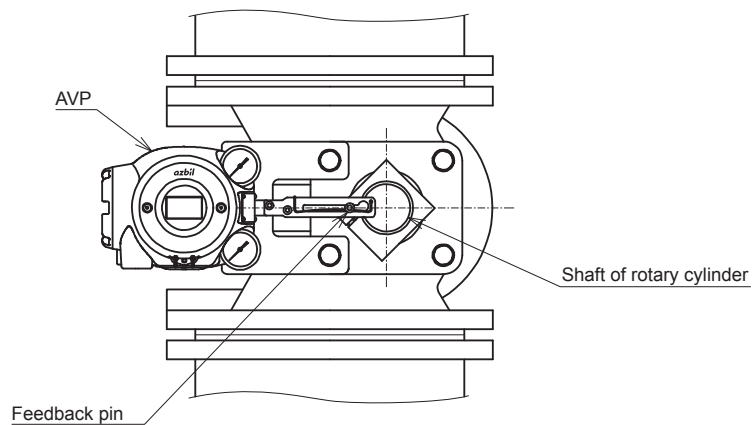

Figure 2-10 Feedback Pin and Feedback Lever Connection for Rotary Cylinder (Large Cylinder)

## 5) Maintenance space behind the device

The device has a nozzle flapper mechanism in the back of the main unit. When cleaning the flapper, you must remove the pilot relay cover secured to the back with three screws. Design the clamp and feedback mechanism to ensure maintenance space for cleaning.

## 6) Installing the device with the LCD facing upwards

If you install the device with the LCD facing upwards, use the accessories below as required depending on the circumstances. (Refer to 6-9, "Resale Parts.")

- LCD cover (material: silicone rubber)

This cover reduces deterioration of the LCD due to sunlight (ultraviolet radiation). Use the cover if the device is used in a place with strong sunlight (outdoors, etc.).

### Cautions



Before mounting or removing the LCD cover, it is necessary to remove the face cover from the main unit. Take care as you work not to touch sharp parts of the face cover, such as the rim. You might be injured.

### Handling Precautions:

Remove the face cover when checking the LCD.

- Pressure gauge elbows

The elbows are for mounting the pressure gauges if the device is installed in a place with direct exposure to rainwater (outdoors, etc.). (If the pressure gauges are installed facing upward, they will be damaged by rainwater.)

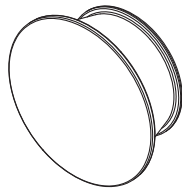

Front

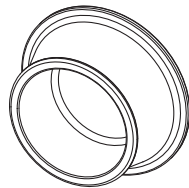

Back

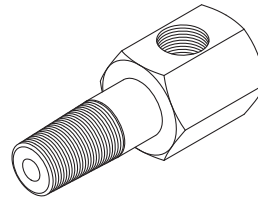

Figure2-11 LCD cover

Figure2-12 Pressure gauge elbow

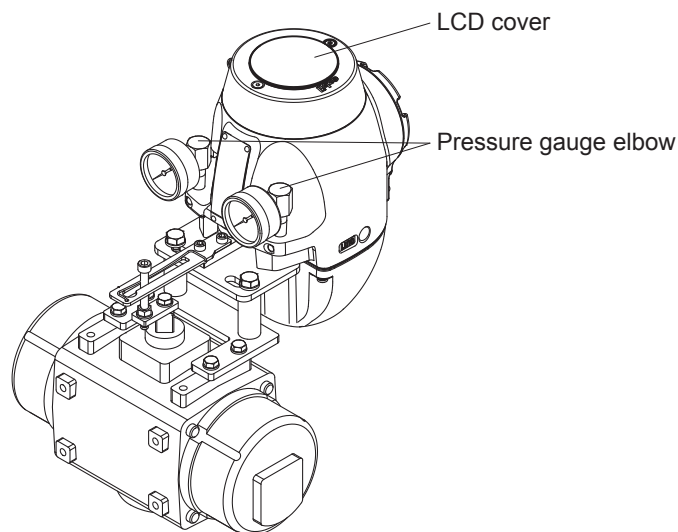

Figure2-13 Example of LCD cover and pressure gauge elbow mounting

## 2-3-2 Pneumatic Piping Connection

This section describes how to supply the air for the device to drive the actuator.

### 1) Air supply system

Supply air must be clean and dry to stably use the device for a long time. A typical example of an air supply system is shown in the figure below.

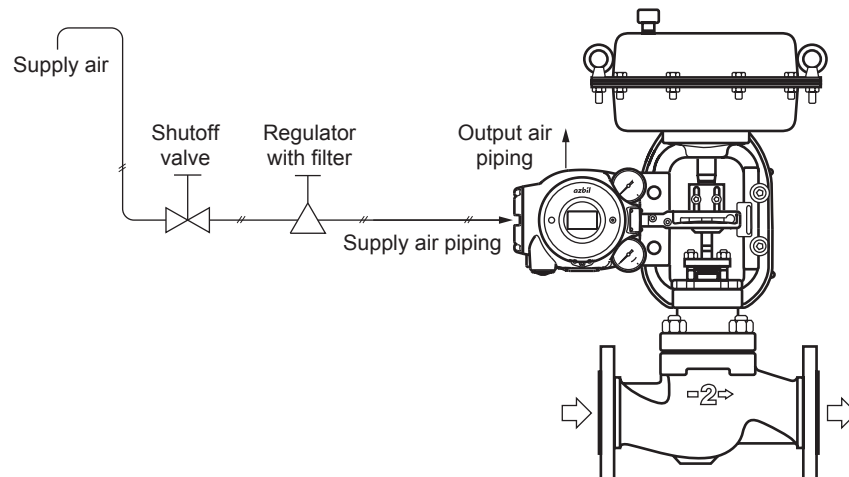

Figure2-14 Air Supply System

### 2) Supply air

Use supply air that conforms to the instrumentation air standards (on page 2-2).

### 3) Regulator with filter

- The regulator with filter is used to adjust the pressure of the supply air to the device.
- Install this valve as close to the main unit of the device as possible.
- The control valve can be manually operated by using the A/M switching function. (The double-acting actuator does not support manual operation.)
- Use a 3- $\mu$ m or finer filter.
- The filter removes solid materials from supply air.
- If the filter is not equipped, separately insert a (3- $\mu$ m or finer) filter immediately before the regulator.
- Install the regulator so that the drain faces downward.
- If you select the built-in Azbil regulator, the filter is built into the device before shipment.

### 4) Shutoff valve

- The shutoff valve is used to temporarily stop supplying air to the device.
- With this valve, the device or control valve can be removed without having to stop the whole air supply system during maintenance or other operations.

## 5) Piping

- Use piping with an inside diameter of 6 mm.
- When using the device in a corrosive atmosphere, select piping appropriate to the environment of the installation location. For example, you may use the vinyl-coated copper pipe.
- To prevent air leaks, be sure to use a fitting that is appropriate for the pipe.

## 6) Connection positions

The positions of the supply air connection port and output air connection port are shown in the figure below. Select the dimensions of the connection port screws according to the specifications.

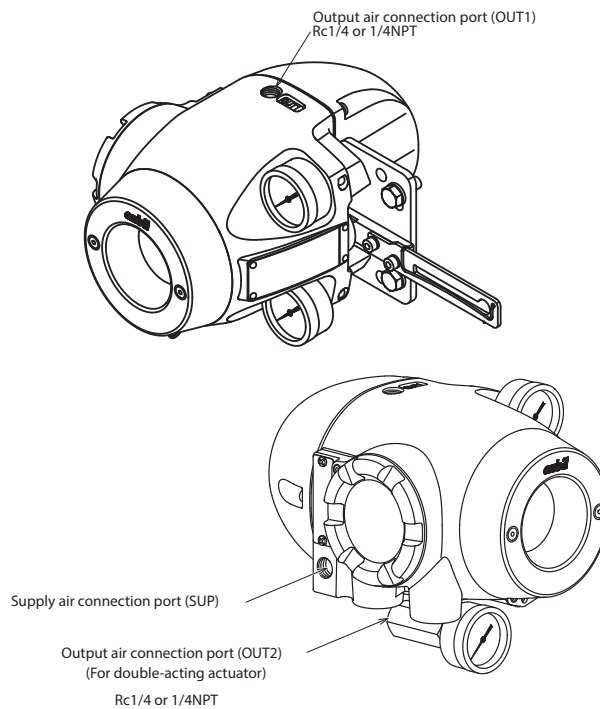

Figure 2-15 Pneumatic Piping Connection

### **!** Handling Precautions:

When connecting the electromagnetic valve for emergency shutoff, air valve, or other part, install it between the output air connection and the actuator rather than the supply air connection side of the device.





## 7) Mounting procedure

The procedure for connecting pneumatic piping to operate the device is shown below.

Step	Work
1	<p>Connect the joint for piping to the connection port using seal tape.</p> <p><b>! Handling Precautions:</b></p> <ul style="list-style-type: none"> <li>- Use seal tape as the seal material. Avoid using solid or liquid seal material if possible.</li> <li>- Do not let the seal tape get in the piping.</li> <li>- If you do use a liquid seal, make sure that no drops of the seal material get in the piping.</li> </ul>
2	<p>Connect the supply and output pipes to each joint in consideration of the arrangement of the piping.</p> <p><b>! Handling Precautions:</b></p> <ul style="list-style-type: none"> <li>- For the double-acting actuator, the connection between output air connection ports OUT1 and OUT2 and the actuator is determined by the valve operation. Check the valve operation before connecting pipes.</li> <li>- Sufficiently flush piping before connection to prevent burrs on the piping or other foreign objects from getting in the piping.</li> <li>- Keep the output air piping as short as possible.</li> </ul>
3	<p>After all piping is complete, make sure that air does not leak.</p>

### 2-3-3 Electrical Wiring Connection

This section describes the methods for electrical wiring for signal input from the controller and signal output to the monitoring system.

<b>⚠ Warning</b>	
	Turn the power off before starting wiring work. Otherwise, electric shock may occur.
	When using the explosion-proof 700 Series in a dangerous place, be sure to connect the wiring while following "Chapter 7 Precautions for the Explosion-Proof 700 Series."
<b>⚠ Cautions</b>	
	Be sure to perform grounding work following the electrical work guidelines in each region.

#### Handling Precautions:

Be sure to attach a blind plug to the unused conduit connection port so that it is completely covered.

#### 1) Connection positions

The figure below shows the terminal block in the terminal box.

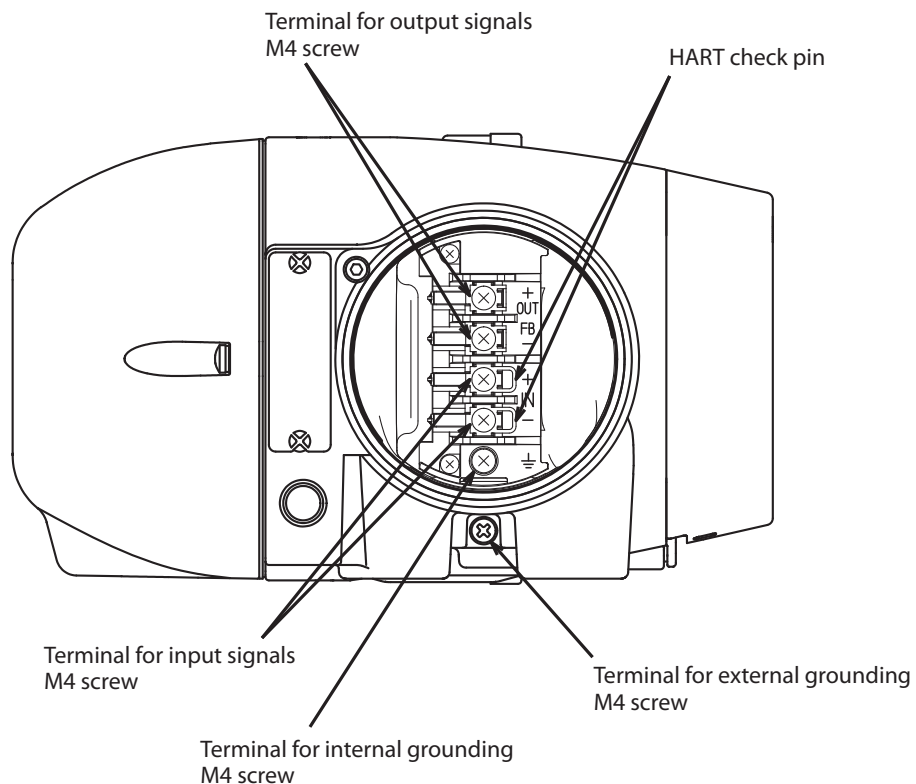

Figure 2-16 Terminal Block in the Terminal Box

## 2) Terminal for external grounding

Connect the external grounding terminal to the case with two washers as follows.

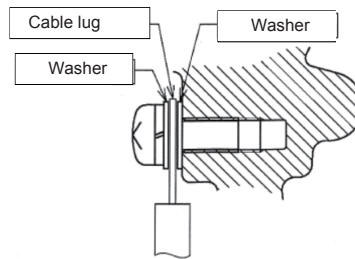

Figure2-17 Connection of External Grounding Terminal

## 3) Without motion transmission (model AVP702)

Remove the terminal box cover and connect the wires as shown in the figure below.

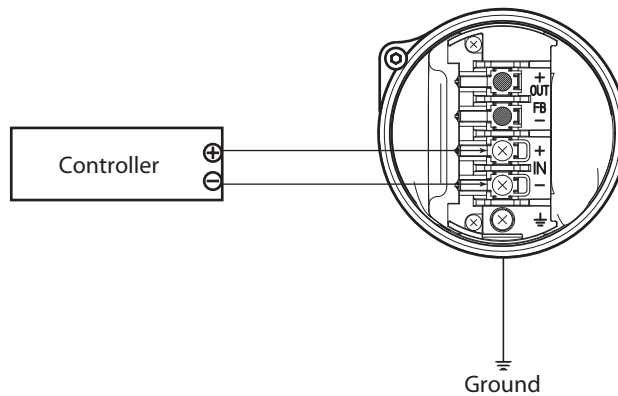
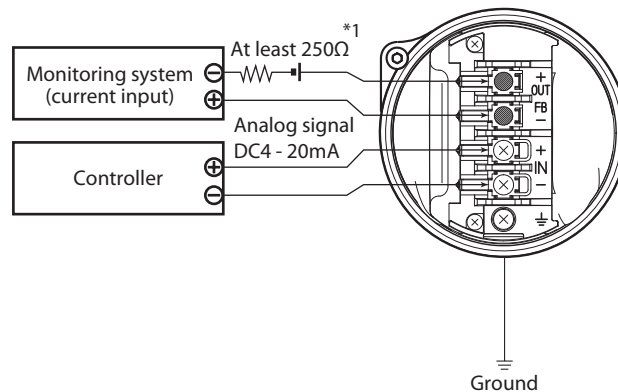

Figure2-18 Electrical Wiring without Motion Transmission (2-conductor cable)

Use only one of the two ground terminals (internal or external) and perform the ground work according to all local laws and ordinances governing electrical work.

## 4) With motion transmission (model AVP701)

Remove the terminal box cover and connect the wires as shown in the figure below.



\*1: For the detailed information of the power supply and resistor, please refer to the figure 2-18 of 2-3-4 Input Signals and Travel

Figure2-19 Electrical Wiring with Motion Transmission (4-conductor cable)

- Use the following wiring method if the monitoring system is a voltage input (1 to 5 V) device.

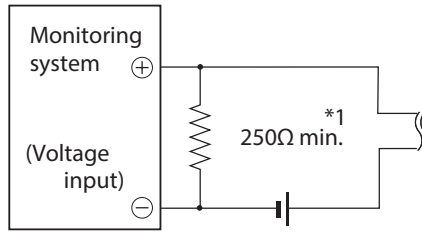

\*1: Refer to the figure 2-18

Figure 2-20 Wiring when the Monitoring System Is a Voltage Input Device

- Use only one of the two ground terminals (internal or external) and perform the ground work according to all local laws and ordinances governing electrical work.

## 2-3-4 Input Signals and Travel Transmission Power

### 1) Input signal

The input signals to this device are 4–20 mA DC. These input signals are also used as the power source to drive the internal circuit.

#### ! Handling Precautions:

- Do not use any more than 24 mA DC.
- It will not operate properly with less than 3.85 mA DC.

<b>! Cautions</b>
<div style="display: flex; align-items: center;"> <div style="border: 1px solid black; border-radius: 50%; width: 20px; height: 20px; margin-right: 5px; display: flex; align-items: center; justify-content: center;"> <div style="border-top: 1px solid black; border-bottom: 1px solid black; width: 5px; height: 10px; margin: 0 auto;"></div> </div> <div> <p>Do not apply the overvoltage to the terminals for the input signal. The overvoltage may cause the failure of the device due to fire damage of the printed wiring boards.</p> </div> </div>

### 2) Travel Transmission Power

The travel transmission power is 17.9–45 V DC.

The load resistance of connections to the travel transmission loop should fall within the operating range shown below for the power voltage to be used.

#### ! Handling Precautions:

Do not apply the travel transmission power than 45 V DC.

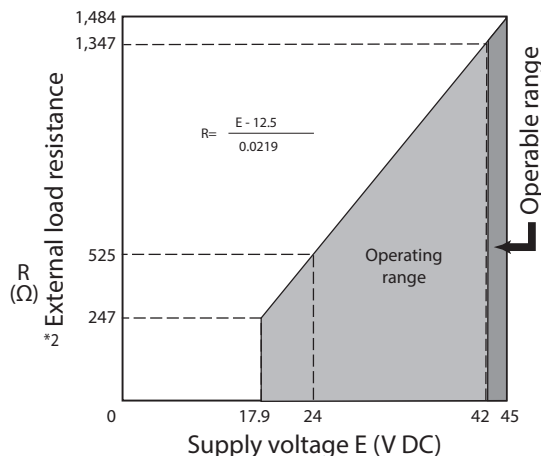

Figure 2-21 Supply Power Voltage/Load Resistance Features

## 2-3-5 Cables

### 1) Selection and conditions of cables

The criteria for selection and the conditions of cables for wiring are described below.

- We recommend using 600-V plastic insulated sheath electric wire CVV (JIS C 3401 by Japanese Industrial Standards) for control with a conductive cross-section of 1.25 mm<sup>2</sup> or a stranded cable with equivalent or higher performance.
- When routing cable in a place subject to electromagnetic noise, use shielded wire CVVS (JCS 4258 by the Japanese Electric Wire & Cable Makers' Association) and metal conduits.
- Select a sheath material that withstands the cable installation environment (including the ambient temperature, corrosive gas, and corrosive liquid).
- Use cable with an outside diameter of 7 to 12 mm. When using a pressure-resistant packing cable adapter, be sure to use packing appropriate for the outside diameter of the cable.
- A crimping terminal with insulated sleeve (for M4 screw) is recommended for terminals.
- The maximum permissible cable length is 1500 m.

### 2) Cable installation

Comply with the following when installing cables between this device and the actuator.

- Avoid installing cables near devices that generate noise such as large capacity transformers, motors, or driving power sources.
- Do not install cables in the same tray or duct with other driving power cables.
- We recommend the use of electrical metal conduits and ducts to prevent water and mechanical damage to electrical lines. Also, always use water-tight glands at conduit connection ports.
- Use electrical metal conduits and ducts for locations exposed to electromagnetic noise.
- When using shielded cable, the cable must be connected to a single point ground on the DCS side.

#### **Handling Precautions:**

Model AVP701/702 are intended for use in industrial locations defined in CE marking directive (EN 61326-1).

### 3) Wiring procedure

The procedure for electrical wiring to operate the device is shown below.

Step	Work
1	Loosen the locking bolts (M4) on the terminal box cover with a hex wrench (3). (Rotate the screw clockwise.)
2	Rotate the terminal box cover counterclockwise to remove it. <b>!</b> <b>Handling Precautions:</b> Be careful not to damage the paintwork with a tool or other object.
3	Remove the dust-proof plug from the conduit connection port.
4	Insert the cable into the conduit connection port. <b>!</b> <b>Handling Precautions:</b> Be careful not to damage the sheath of the cable.
5	Wire the cable to the relevant terminal in the terminal box. <b>!</b> <b>Handling Precautions:</b> <ul style="list-style-type: none"> <li>- Be careful of the polarity.</li> <li>- Sufficiently tighten the terminal screw. The recommend tightening torque is 1.5 N·m.</li> </ul>
6	Apply sufficient waterproof treatment to the conduit to prevent rainwater or other liquid from entering inside. <b>!</b> <b>Handling Precautions:</b> We recommend using silicon non-hardening seal material.
7	Mount the terminal box cover, tighten it securely, and then secure the cover by rotating the lock screw counterclockwise. <div style="border: 1px solid black; padding: 5px; margin: 5px 0;"> <div style="text-align: center; background-color: #cccccc; padding: 2px;"><b>! Cautions</b></div> <div style="padding: 2px;"> <b>!</b> Be careful not to get your finger caught in the clamp.         </div> <div style="padding: 2px;"> <b>!</b> Be careful not to hurt your finger with the edge of cover or the screw threads of the main unit.         </div> </div> <b>!</b> <b>Handling Precautions:</b> Be careful not to damage the paintwork of the device with a tool or other object.

#### **!** Handling Precautions:

The input resistance for the AVP701/702 models must be the equivalent of 475 Ω (600 Ω if equipped with overvoltage protection)/20 mA DC and the inter-terminal voltage must be at least 9.5 V (12 V if equipped with overvoltage protection). Check the controller's allowable load resistance and the output voltage. Note that when the controller's allowable load resistance is less than 475 Ω (600 Ω if equipped with overvoltage protection), an isolator or similar device should be used.

## 2-4 Cable gland and flameproof universal elbow for TIIS Flameproof apparatus

TIIS Flameproof SVP model is provided with a certified cable gland.

The cable gland seals the cable entering the SVP enclosure to withstand an internal explosion and protects the cable from being damaged mechanically and electrically.

Use the dedicated elbow if it is necessary to change the direction of the cable with these models.

### **!** Handling Precautions:

If the device is to be used under the authorization other than that for the TIIS Flameproof standards, the wiring of cables must be performed according to local regulations for electrical installations in explosive atmospheres.

### 1) Structure of the flameproof cable gland

The Flameproof cable gland is shown below in assembled and exploded views.

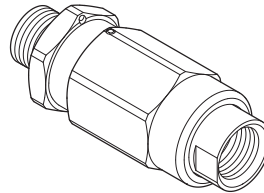

Figure 2-22 Flameproof cable gland

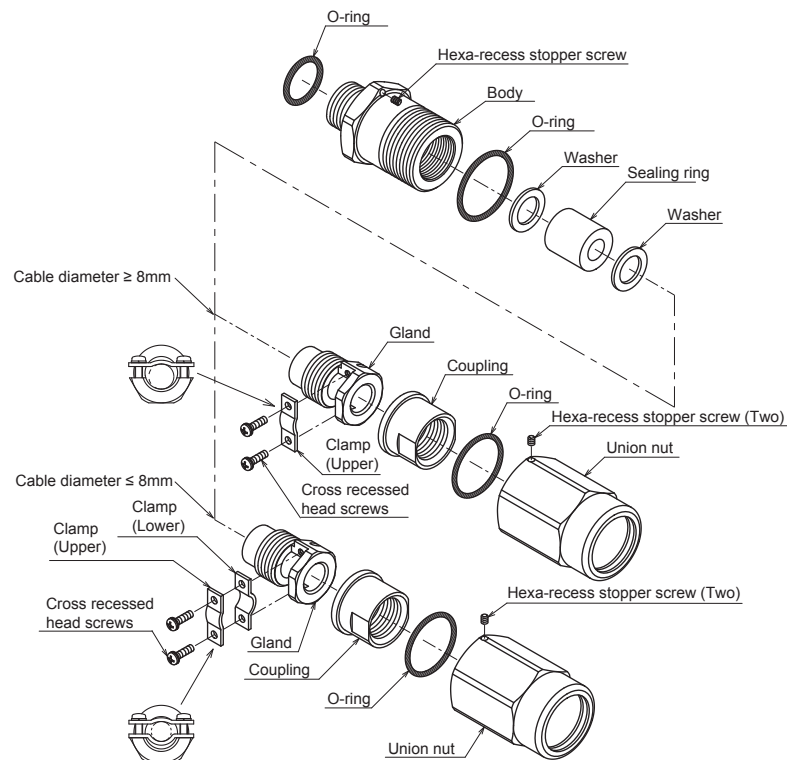

Figure 2-23 Constituent elements of flameproof cable gland

## 2) Structure of the flameproof universal elbow

The figure below shows the universal elbow.

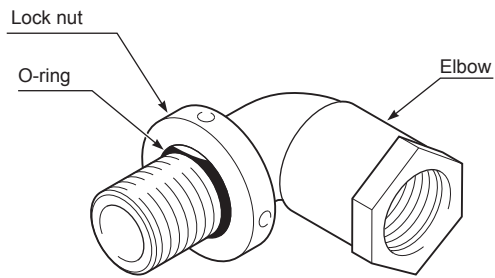
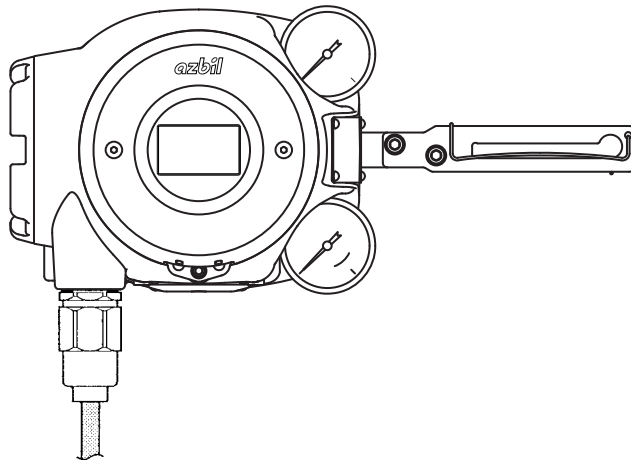

Figure 2-24 Flameproof elbow

## 3) Mounting example

The flameproof cable gland and the universal elbow are used to connect the field wiring cable to the device enclosure, as shown below.

### a) Use of flameproof cable gland



### b) Use of flameproof cable gland and elbow

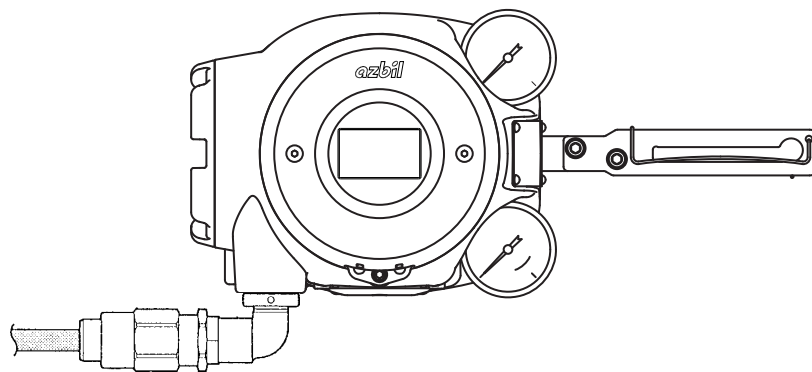

Figure 2-25 Mounting example of flameproof cable gland and elbow



#### 4) Mounting procedure for flameproof cable gland

The procedure for mounting the flameproof cable gland is shown below.

Step	Procedure												
1	<p>Securely screw the main unit of the adapter into the conduit connection port of the terminal box or into the flameproof universal elbow, and fasten the hexagon socket bolt.</p> <p><b>! Handling Precautions:</b> Apply adequate waterproofing to these parts. We recommend the use of silicone resin based non-hardening seal materials.</p>												
2	<p>Refer to the illustrations and insert the cable carefully.</p> <div style="border: 1px solid black; padding: 5px;"> <p style="text-align: center;"><b>! Warning</b></p> <p>If the diameters of the cable and the packing do not match each other, the propagation of flame cannot be prevented. Refer to the table below and select a packing adaptor whose internal diameter matches the outer diameter of the cable.</p> <table border="1" style="margin-left: 20px;"> <thead> <tr> <th data-bbox="775 969 951 1077">Cable outer diameter (mm)</th> <th data-bbox="951 969 1121 1077">Packing inner diameter (mm)</th> <th data-bbox="1121 969 1305 1077">Notes</th> </tr> </thead> <tbody> <tr> <td data-bbox="775 1077 951 1131">7.0 ~ 8.0</td> <td data-bbox="951 1077 1121 1131">8</td> <td data-bbox="1121 1077 1305 1131">Provided</td> </tr> <tr> <td data-bbox="775 1131 951 1184">8.0 ~ 10.0</td> <td data-bbox="951 1131 1121 1184">10</td> <td data-bbox="1121 1131 1305 1184">Built in</td> </tr> <tr> <td data-bbox="775 1184 951 1238">10.0 ~ 12.0</td> <td data-bbox="951 1184 1121 1238">12</td> <td data-bbox="1121 1184 1305 1238">Provided</td> </tr> </tbody> </table> <p><b>! The cable outer diameter is 8mm max., fix the cable gland with the clamps.</b></p> </div> <p><b>! Handling Precautions:</b> Pay attention to the surface of the device. Tools may cause damage the surface.</p>	Cable outer diameter (mm)	Packing inner diameter (mm)	Notes	7.0 ~ 8.0	8	Provided	8.0 ~ 10.0	10	Built in	10.0 ~ 12.0	12	Provided
Cable outer diameter (mm)	Packing inner diameter (mm)	Notes											
7.0 ~ 8.0	8	Provided											
8.0 ~ 10.0	10	Built in											
10.0 ~ 12.0	12	Provided											
3	<p>Screw the gland into the main unit of the adapter to secure it in place.</p> <div style="border: 1px solid black; padding: 5px;"> <p style="text-align: center;"><b>! Warning</b></p> <p><b>! To prevent injuries due to a spark travel, be sure to tighten down the packing adequately.</b></p> </div>												
4	<p>Pass the cable through the body and insert it into the terminal box.</p>												
5	<p>Screw the union nut onto the body and tighten it down securely to hold it in place. Then, tighten the union nut's recess screw.</p>												

## 5) Mounting procedure for flameproof universal elbow



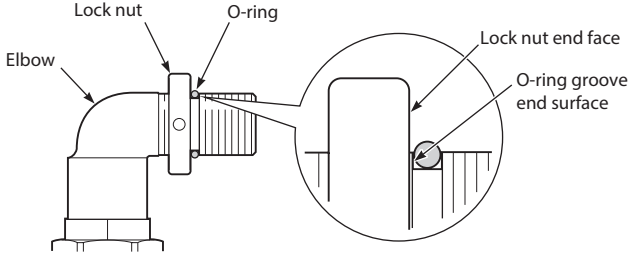

The procedure for mounting the flameproof universal elbow is shown below.

Step	Procedure
1	<p>Align the end surface of the lock nut with the end surface of the O-ring groove as shown below.</p>  <p>Figure 2-26 Arrangement of lock nut and O-ring</p>
2	<p>Screw the flameproof universal elbow into the terminal box conduit connection port until the lock nut end surface hits the connection port end surface.</p> <p>When two elbow are used, at first, screw the first elbow into the terminal box. Next, screw the second elbow into the terminal box in the reverse direction to the first elbow.</p> <p><b>⚠ Handling Precautions:</b> Apply adequate waterproofing to these parts.</p>
3	<p>Turn the flameproof universal elbow to loose in the desired direction.</p> <p><b>⚠ Handling Precautions:</b> Do not loosen it more than 1 turn.</p>
4	<p>Lock the flameproof universal elbow in place by tightening down the lock nut using the special tool.</p>

# Chapter 3 Operation of the 700 Series

This chapter describes how to start operating the device and adjust the device using the local user interface (LUI). When you purchase the device alone, be sure to read “Installation of the 700 Series” before reading this chapter.

## 3-1 Local User Interface (LUI)

Four push buttons on the LUI (with , , , and  symbols) can be operated by removing two screws ((2.5-mm) hexagonal socket bolts) from the front cover of the device.

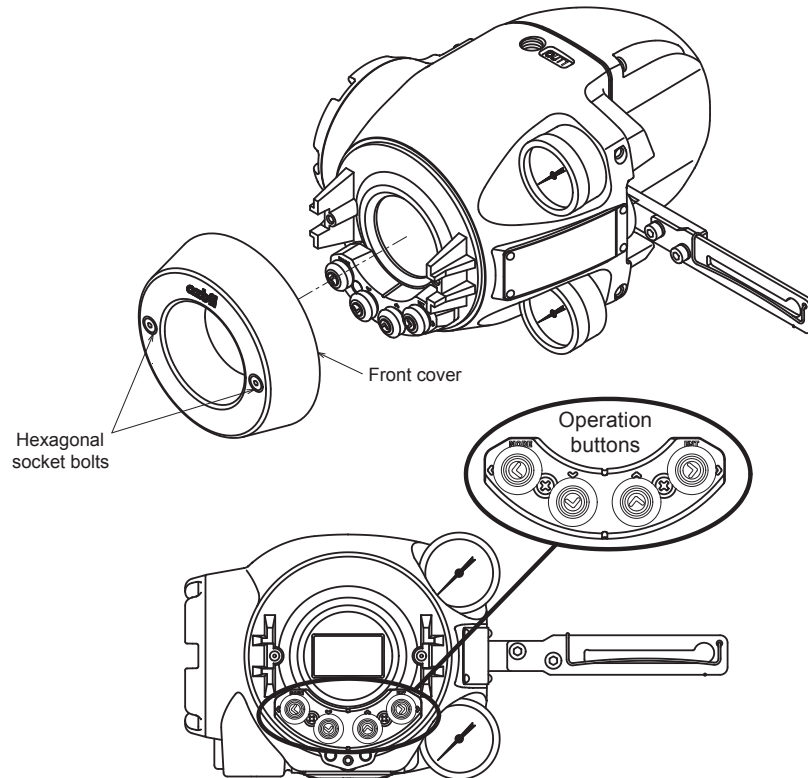









Figure 3-1 LUI Structure with the Front Cover Removed

Table 3-1

Key input	Monitor mode	Setup mode
	Switches between display categories.	Goes to the next display.
	Selects the next item.	
	Selects the previous item.	
	Switches between display categories.	Goes back to the previous display.
 Hold down	Switches between setup mode and monitor mode.	
 Hold down		Executes the function.

The LUI supports the monitor and setup modes.

In monitor mode, the normal, detailed and status are available. The normal monitor can be used to monitor data such as opening and input signals and it displays alarm information if a self-diagnostic alarm is issued.

To change from monitor mode to setup mode, hold down the  button. In setup mode, operations such as auto setup and zero span adjustment can be performed. Figure 3-2 shows a diagram of the LUI screen transition.

The LUI displays the dynamic values in the device and can be used to adjust and set up the following five functions.

- Auto setup function
- Zero span adjustment
- Supply pressure bypass function
- Specification of control parameters
- Setup of the control valve system

This section explains adjustment and setup using the LUI.

### **!** Handling Precautions:

- Operations cannot be performed from the host when you are using the LUI to make adjustments or change settings.
- If there is an object near the operation button, remove it before operation.
- Please return display to the normal monitor when you want to let you display alarm.  
Because you can not display alarm when let you display the monitor except the normal monitor.
- Alarm and the present value are displayed at that time of the alarm outbreak in turn.
- If you have made adjustments, make sure to verify them by checking device operation. If you have also modified settings, make sure that they were modified correctly.



Enter the password if a password has been set.

If you use another host or communicator for communication during setup, this screen is displayed and the setup mode cannot be started.

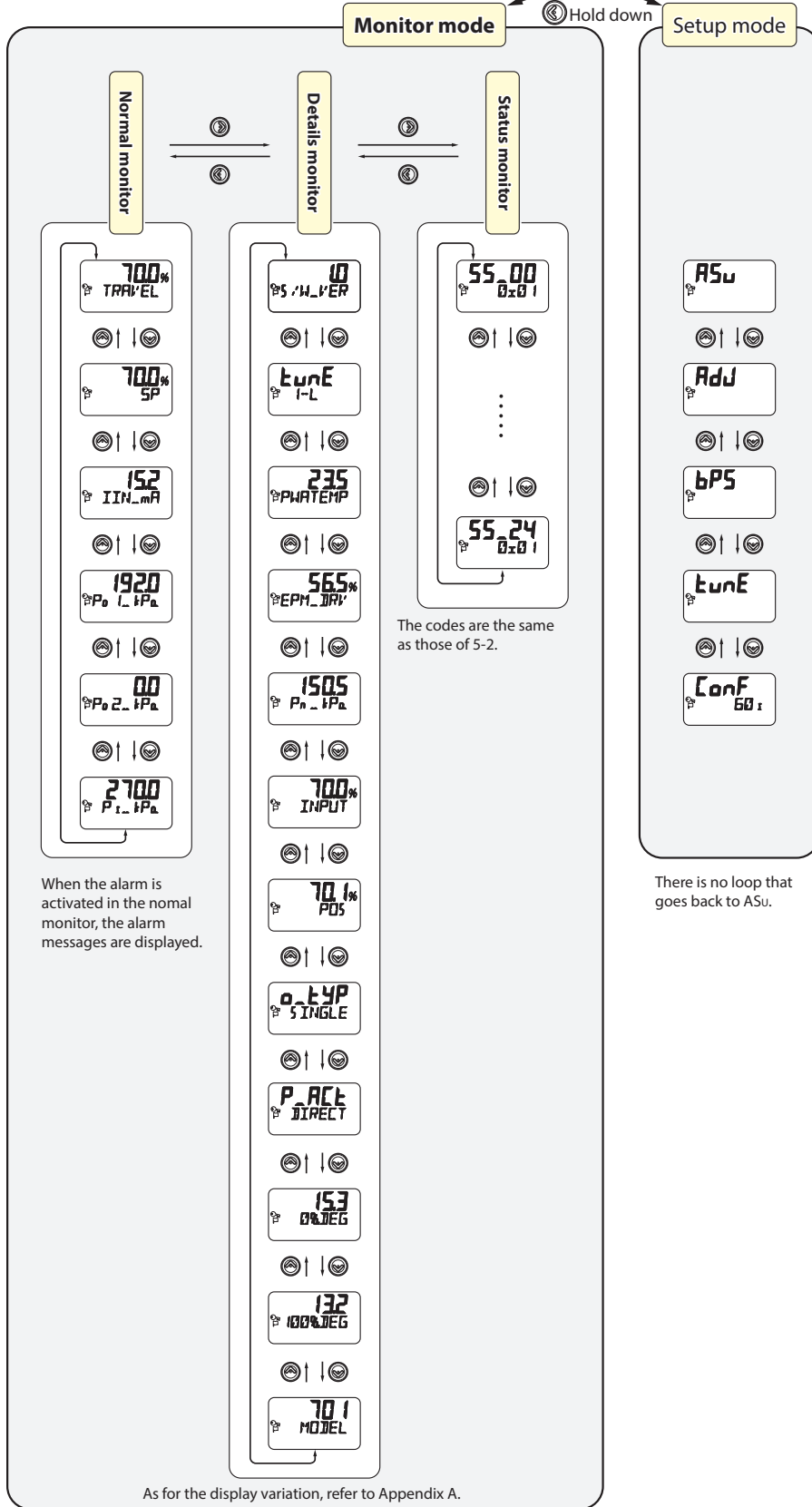

Figure 3-2

## 3-2 Adjustment before Operation

Perform auto setup before using the device. Then, adjust the zero span if necessary.

The zero span adjustment function in the device electrically sets the fully closed and fully open positions of the valve independently of each other. Therefore, you can adjust each of these positions without interfering with the other one.

### 3-2-1 Auto Setup

There are two auto setup methods.

- Method using the LUI
- Method through HART communication

This section describes the method using the LUI. For the method through HART communication and the details of auto setup, refer to Chapter 4.

#### Handling Precautions:

- The input signal should be 5 mA or more. If it is less than 5 mA, auto setup may not operate normally.
- If any of the self-diagnostic messages shown in Table 4-5 in 4-2-20, "Diagnostic Messages" appears, auto setup cannot be executed.
- Once auto setup and zero span adjustment are completed, always remember to change the input signal and to check the opening, valve travel, and other valve operations.
- Correctly set the actuator type and feedback lever position when fully closed before starting auto setup.
- In some cases, the dynamic characteristic is not set correctly with the actuator capacity, operation stroke, inner diameter of pneumatic piping and piping length. If this occurs, refer to '4-2-5 Control Configuration' and adjust the dynamic characteristic manually.
- When the actuator size is Custom, the size is not changed with the Auto setup. When selecting the actuator size with the Auto setup, set the size as below.
  - Param 1 to 6 or
  - Param A to C.
- In some cases, the initial setting is not same even though the actuator and valve size is same. Please perform the operation check and configuration of the device if necessary.
- There is a possibility that the forced open value described on page '4-2-7 Travel Cutoff' may change after performing the Auto-setup operation. Please reconfigure the forced open value if necessary.
- If the booster relay is on, and is operating the Auto-setup function, there might be a possibility of hunting. In this case, adjust the booster's sensitivity, or refer to '4-2-5 Control Configuration and adjust the dynamic characteristic manually.
- If a speed controller is incorporated, set it to full open and execute auto-setup. Afterwards, adjust the speed with the speed controller.
- When the device is purchased separately, its initial settings are set to those in the list of default values in '6-7 List of Default Values for Internal Data' of this manual. Because the default actuator direction is reverse, if you mount the device on the direct actuator the device will not work. Please be sure to execute the auto setup program before operation and be sure that appropriate settings are created in the device.

## Cautions



It is dangerous during auto setup because the fully closed valve moves to fully open. Be prepared in advance to prevent injury and effects on the process when the valve moves.

The Actuator Type is set to Linear and the Valve Closed Position is set to Down when the valve is fully closed at the time of shipment unless there are other shipment setup instructions. If factory setting (initial setup) is requested, check the settings at the time of shipment. Configure settings as needed.

If auto setup fails, refer to 5-1-5, "Auto Setup Failure."

The reverse action actuator fully closes, fully opens, and fully closes the valve when auto setup starts. The direct action actuator fully opens, fully closes, and fully opens the valve. Then, it is opened to between 20% and 25% and between 80% and 85%.

After auto setup, the valve moves to the opening appropriate to the input signal.

Check the following points before starting auto setup.

- Actuator Type

- Linear (standard): Direct-acting actuator

- Rotary/90°: When the distance between the feedback lever of the rotary actuator (90°) and the pin is longer than the distance from the valve shaft

- Rotary/Other: When the distance between the feedback lever of the rotary actuator (around 60°) and the pin is longer than the distance from the valve shaft

- Rotary(sub)/90°: When the distance between the feedback lever of the rotary actuator (90°) and the pin is shorter than the distance from the valve shaft

- Rotary(sub)/Other: When the distance between the feedback lever of the rotary actuator (around 60°) and the pin is shorter than the distance from the valve shaft

- Valve Closed Position

- DOWN (standard)

- UP



**(1) Procedure for performing auto setup**

Step	Work	LUI display
1	Loosen two (2.5-mm) hexagonal socket bolts and remove the front cover. (A sample initial setup status of the LUI screen is shown.)	
2	Press and hold the  button to enter Settings mode. Enter the password if prompted to do so. For how to set the password, refer to "3-2-5 Password". To change Actuator Type or Valve Closed Position, refer to step (3).	
3	Wait until the input signal becomes at least 5 mA and press the  button once. Check that the screen on the right is displayed and press and hold the  button again to perform auto setup.	 
4	The valve, which is initially fully closed, is fully opened and fully closed again. Then, it is opened to between 20% and 25% and between 80% and 85%. After the valve operation ends, the LUI screen changes and the opening appropriate to the input signal is set.	
5	When you press the  button, the initial screen of the auto setup is displayed again.	

The 'FAIL' signs in the auto setup operation are as follows.

FAIL00: The auto setup is failed. (The valve does not move, etc.)

FAIL01: The input signal is low level.

FAIL02: A function except for the auto setup is in operation.

















FAIL90: The auto setup is forcibly shut down. (Auto setup was stopped from the LUI.)

For countermeasures for these problems, refer to 5-1-5, "Auto Setup Failure."

**(2) Procedure for aborting auto setup**

Step	Work	LUI display
1	To abort auto setup during execution, press the  button.	
2	Holding down the  button aborts the execution. If auto setup is aborted, data is not saved.	
3	When you press the  button, the screen on the right is displayed again.	

**(3) Procedure for specifying Actuator Type and Valve Closed Position**

Step	Work	LUI display
1	Display the screen on the right by repeatedly pressing the  and  button.	
2	Press the  button.	
3	Select an appropriate actuator type with the  and  buttons and press the  button.	
4	Select an appropriate feedback lever position when the valve is fully closed with the  and  buttons and hold down the  button to set that position.	
5	The specified actuator type and feedback lever position when the valve is fully closed are displayed. Check the settings.	
6	Go back to the desired menu with the  and  buttons.	

### 3-2-2 Zero Span Adjustment

After auto setup, check the 0% and 100% positions. If adjustment is required, adjust the zero span.



The following two zero span adjustment methods are available.

- Method using the LUI
- Method using HART communication (This method is further broken down into the following four methods.)
  - Auto Travel Calibration
  - Angle Correction
  - Manual Setting
  - Change Travel Angle





This section describes the method using the LUI. For the method using HART communication, refer to Chapter 4.











#### Handling Precautions:

If you adjust the span after auto setup, the forced fully opening value is automatically changed to the value calculated by subtracting 1% from the overstroke percentage.













 <b>Cautions</b>	
	Then zero span adjustment is dangerous because of valve action. Take measures in advance to prevent injury to personnel and effects on the process in case the valve operates.

#### **(1) Procedure for adjusting the zero span**



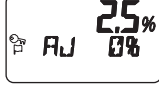



Step	Work	LUI display
1	Loosen two hex socket bolts (2.5 mm) to remove the front cover.	
2	Press and hold the  button to enter Settings mode. Enter the password if prompted to do so. For how to enter the password, refer to "3-2-5 Password".	
3	Press the  button to display the screen on the right (ADJ).	

Step	Work	LUI display
4	Press the  button, select whether to adjust the angle for 100% or 0% opening with the  and  buttons, and press the  button. (Refer to “(2) Procedure for adjusting the angle.”)	 (100% opening angle adjustment)
		 (0% opening angle adjustment)
	To manually adjust each opening rather than using the opening adjustment function, select manual adjustment for 100% opening (0% opening) with the  and  buttons and press the  button. (Refer to “(3) Procedure for manual adjustment.”)	 (100% opening manual adjustment)
		 (0% opening manual adjustment)

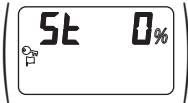
**(2) Procedure for adjusting the angle**

Step	Work	LUI display
1	Select the angle (COARSE, MID, FINE) for 100% opening adjustment (0% opening adjustment) with the  and  buttons and press the  button.  <div style="display: flex; align-items: center; gap: 20px;"> <div style="border-left: 1px solid black; border-right: 1px solid black; padding: 0 10px;">           COARSE:    Angle 1°            MID:            Angle 0.1°            FINE:           Angle 0.01°         </div> </div>	  
2	Adjust the angle by pressing the  button to increase the opening and pressing the  button to decrease the opening.	  
3	Pressing the  button displays the current opening and output air pressure (Pout1). Check that the angle is properly adjusted.  If further adjustment is required, go back to the adjustment screen with the  button.	  

**(3) Procedure for manual adjustment**

Step	Work	LUI display
1	Manually specify the desired position for 100% opening (0% opening).	 
2	Press the  button.	 
3	Check that the desired position is selected and then hold down the → button. This adjusts the 100% opening (0% opening).	 



















### 3-2-3 Supply Bypass

Supply bypass allows the valve to be fully closed and opened and enables operation with the regulator.

(For double-acting actuators, the valve can only be fully opened or closed.)

 <b>Cautions</b>	
	When the supply bypass operates, it is dangerous because the valve moves. Be prepared in advance to prevent injury and effects on the process when the valve moves.

#### (1) Procedure for supply bypass

Step	Work	LUI display
1	Loosen two (2.5-mm) hexagonal socket bolts and remove the front cover.	
2	Hold down  to enter setting mode. If a password is required, enter the password. For details on password entry refer to 3-2-5, "Password."	
3	Press the  button to display the screen shown on the right.	
4	Press the  button to go to the screen shown on the right. To set the output air pressure to 0, hold down the  button.  (If the output air pressure is already 0 or it is set to the supply air pressure at the supply bypass, go to the screen of step 7 where the supply bypass can be operated.)	
5	To change the output air pressure to the supply air pressure, press the  button to display the screen on the right and hold down the  button.	
6	If supply bypass conditions (e.g. the input signal is less than 5 mA) are not satisfied, the screen on the right is displayed.	
7	If supply bypass conditions are satisfied, the screen shows that each bypass operates.	 
8	To clear supply bypass operations, press the  button to display the screen shown on the right.	
9	Holding down the  button clears the supply bypass.	

The 'FAIL' signs in the supply bypass operation are as follows.

FAIL01: The input signal is low level.

FAIL02: A function except for the supply bypass is in operation.

FAIL90: The auto setup is forcibly shut down.

### 3-2-4 Control Parameters

Control parameters are determined by Actuator Size (Param 1 to 6, A, B, C) and Friction Level (Light(L), Medium(M), Heavy(H)).

Table 3-2 Actuator size

Actuator Size	Stroke Speed[s]	Actuator Model	Actuator Diaphragm capacity[cm <sup>3</sup> ]
PARAM C	to 0.25	-	200
PARAM B	to 0.35	-	300
PARAM A	to 0.45	-	400
PARAM 1	to 0.85	PSA1, PSK1	600
PARAM 2	to 2.0	PSA2, HA2	1400
PARAM 3	to 6.5	PSA3, HA3	2700
PARAM 4	to 8.15	PSA4, HA4	6600
PARAM 5	to 12	PSA6	8100
PARAM 6	to 99	VA5	25300
Custom	-	-	*

\* Consult an Azbil Corp. service representative.













Table 3-3 Friction Level

Friction Level	Gland packing material example
HEAVY	Graphite packing
MEDIUM	Yarn packing
LIGHT	Type V PTFE packing

\* This is not decided with the materials in a parameter to be decided by frictional force of the grand packing.

 <b>Cautions</b>	
	It is dangerous because the valve moves when control parameters are changed. Be prepared in advance to prevent injury and effects on the process when the valve moves.

**(1) Procedure for specifying control parameters**

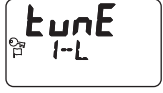







Step	Work	LUI display
1	Loosen two (2.5-mm) hexagonal socket bolts and remove the front cover.	
2	Hold down the  button to start the setup mode. Enter the password if prompted to do so. For how to enter the password, refer to "3-2-5 Password".	
3	Press the  button to display the screen shown on the right (tune).	
4	Press the  button to display the screen on the right and select Param 1 to 6, A, B, or C for Actuator Size by operating the  button, and press the  button.	
5	Select L (Light), M (Medium), or H (Heavy) for Friction Level and set it by holding down the  button. To return the setting to its original value, reset the value with  before holding down the  button.	
6	Check the specification result when it is displayed.	



### 3-2-5 Password

The password consists of four letters. Use alphanumeric characters for the password.

#### ***How to enter the password***

Step	Work	LUI display
1	Check that the password screen (screen on the right) is displayed and that the rightmost digit is blinking. Select the alphanumeric character of the specified password with the  or  button and press the  button.	
2	The second digit from the right starts blinking. Specify all four digits in the same way. To return to and specify a digit to the left of the current digit, use the  button.	
3	After specifying the fourth digit, press and hold the  button.	
4	If the password matches, it changes to Settings mode. If not, the error screen shown on the right is displayed. In this case, enter the password again.	

## 3-3 Starting Operation

### 3-3-1 Preoperation Check

Check the following points before starting operation.

- The device is properly installed and the feedback lever, feedback pin and other parts are not damaged or fractured.
- The pneumatic piping is completely connected and an appropriate supply air pressure is supplied. (Air is not leaking.)
- Is the input signal (4 to 20 mA DC) being applied.

#### 1) Procedure for checking the device operation

The procedure for checking the device operation is shown below.

Step	Work
1	Check that the control valve travel is being changed to suit the preset characteristics by changing the input signal from the controller (constant current source). If operation is not normal, refer to "Chapter 5 Troubleshooting."
2	After confirming normal operation, tightly secure the terminal cover.

# Chapter 4 Operation with HART Communication

This chapter describes the operations performed using HART communication. For the basic operations, the relationship between the mode and data settings, the specification and modification of data, how to save each type of data, and other descriptions, refer to this chapter.

## 4-1 Operation with HART Communication

This section describes the menu configuration and functions for adjustment and setting items using HART communication. The HART communication tool is used to adjust, set, and read data for this device. For details, see the operation manual for the HART communication tool.

### ■ HART communication tool and wiring

Wire it as shown in the following diagram.

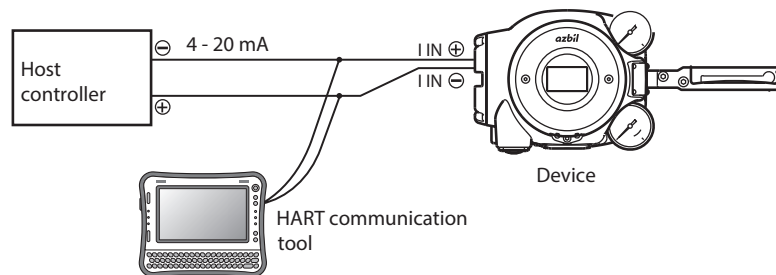

Figure4-1

### ■ Before starting HART communication

Check the following before starting communication.

- The wiring connections with this device are completed.
- The input signal (4–20 mA DC) from the controller (constant current source) is correctly applied.
- 

#### ⚠ Handling Precautions:

- If there is no input signal from the controller, connect the constant current source to the input signal terminal (IN). The lines from the controller must be removed in this case.
- Please download the latest DD (Device Description) when using the HART communication tool.  
(Download from <http://www.azbil.com/products/bi/iap/index.html>)

## 4-2 Setup and Adjustment of Device

Set up and adjust the functions required for the device to operate properly.

This section describes the menu of the 475 communicator.

To change settings and make adjustments, select [Device] → [Configuration] → [Operator Action Setting] → [Allow operation action].

This allows you to change settings and make adjustments, and also restricts settings changes and adjustments from LUI and the other HART master\*.

\* HART communication master stations are configured for either the primary or secondary. In most cases, the host system is the primary and the 475 communicator is the secondary.

Once the settings and adjustments are complete, select [Device] → [Configuration] → [Operator Action Setting] → [Forbid operation action]. The LUI becomes inoperable if you do not perform this operation. (When there has been no HART communication for more than 10 minutes, this operation will be performed automatically and the LUI becomes operable.)

### 4-2-1 Process Variables

The measurement value data present when the device is operating can be viewed.

Select [Process Variables].

#### ■ Checking measured values

Selecting [Process Variables] allows the following items to be checked.

Table 4-1 Description of Each Part

Item	Description
Input (mA)	Displays the current input value.
Input (%) *1	Displays the input signal (%).
Set Point (SP) *2	Displays the input signal (%) following flow type conversion.
Travel	Displays the valve travel (%).
Position *1	Displays the valve travel following flow type conversion.
Drive Signal	Displays the EPM (electric-pneumatic converter) drive signal (%).
Po1	Displays the output air pressure (OUT1).
Po2	Displays the output air pressure (OUT2).
Ps	Displays the supply air pressure (SUP).
Pn	Displays the nozzle back pressure.
Temperature	Displays the temperature inside the positioner.

\*1: This is not displayed if flow type conversion was not performed.



\*2: The set point during forced closure is fixed at 0 %.

The set point during forced opening is equal to the travel cutoff high +1 %.

## 4-2-2 Auto Setup

Auto setup is a function that automatically performs basic adjustments and setup after the device is assembled onto the actuator.

Select [Device]→[Basic Setup]→[Auto Setup].

 <b>Cautions</b>	
	It is dangerous during auto setup because the fully closed valve moves to fully open. Be prepared in advance to prevent injury and effects on the process when the valve moves.

### Handling Precautions:

- The input signal should be 5 mA or more. If it is less than 5 mA, auto setup may not operate normally.
- If any of the self-diagnostic messages shown in Table 4-5 in 4-2-20, "Diagnostic Messages" appears, auto setup cannot be executed.
- When auto setup and zero span adjustment are complete, change the input signal and be sure to check valve operations such as opening and shutoff.
- Before the Auto setup operation, set the position of the actuator type and the forced close feedback lever correctly.
- In some cases, the dynamic characteristic is not set correctly with the actuator capacity, operation stroke, inner diameter of pneumatic piping and piping length. If this occurs, refer to '4-2-5 Control Configuration' and adjust the dynamic characteristic manually.
- When the actuator size is Custom, the size is not changed with the Auto setup. When selecting the actuator size with the Auto setup, set the size as below.
  - Param 1 to 6 or
  - Param A to C.
- In some cases, the initial setting is not same even though the actuator and valve size is same. Please perform the operation check and configuration of the device if necessary.
- There is a possibility that the forced open value described on page '4-2-7 Travel Cutoff' may change after performing the Auto-setup operation. Please reconfigure the forced open value if necessary.
- If the booster relay is on, and is operating the Auto-setup function, there might be a possibility of hunting. In this case, adjust the booster's sensitivity, or refer to '4-2-5 Control Configuration and adjust the dynamic characteristic manually.
- If a speed controller is incorporated, set it to full open and execute auto-setup. Afterwards, adjust the speed with the speed controller.
- When the device is purchased separately, its initial settings are set to those in the list of default values in '6-7 List of Default Values for Internal Data' of this manual. Because the default actuator direction is reverse, if you mount the device on the direct actuator the device will not work. Please be sure to execute the auto setup program before operation and be sure that appropriate settings are created in the device.

Check the Actuator Type and Valve Closed Position before starting auto setup.

The Actuator Type is set to Linear and the Valve Closed Position is set to Down when the valve is fully closed at the time of shipment unless there are other shipment setup instructions. If factory setting (initial setup) is requested, check the settings at the time of shipment. Configure settings as needed.

If auto setup fails, refer to 5-1-5, "Auto Setup Failure."

The reverse action actuator fully closes, fully opens, and fully closes the valve when auto setup starts. The direct action actuator fully opens, fully closes, and fully opens the valve. Then, it is opened to between 20% and 25% and between 80% and 85%.

After auto setup, the valve moves to the opening appropriate to the input signal.

The following items are automatically adjusted and set during auto setup.

(1) Zero span adjustment

The zero point is set to the travel when the valve is fully closed. The span point (100 % travel) is set in such a way that the travel when the valve is fully opened is Travel Cutoff High + 1 %. (If Travel Cutoff High is 99 %, the fully opened position is the span point.) If the span is adjusted after auto setup, Travel Cutoff High will be automatically changed and saved.

(2) Input signal range (Input Range), Input Range Low (Close) and Input Range High (Open) settings

The input range settings are changed so that the valve operation direction (close or open) when the input current is lowered from 20 mA to 4 mA is the same as the direction for power-off (input current: 0 mA).

Example: If Valve Closed Position is set to DOWN (normal)

When the actuator action is reversed:

Input Range Low (Close) = 4mA, Input Range High (Open) = 20mA

When the actuator action is forwarded:

Input Range Low (Close) = 20mA, Input Range High (Open) = 4mA

(3) Specification of Actuator Size

Select the actuator size from among Param 1 to Param 6, Param A, B, and C.

(4) Specification of Friction Level

Select the friction level of the gland packing from among LIGHT, MEDIUM, and HEAVY.

(5) Specification of Feedback Lever Motion

Specify UP or DOWN as the operation of the feedback lever when output air pressure OUT1 increases.

(6) Specification of Positioner Action

When the input signal is "Disconnected," the positioner operation is forward operation (Direct) if the output air pressure is 0.



When the input signal is "Disconnected," the positioner operation is reverse operation (Reverse) if the output air pressure is the supply air pressure.

(7) Specification of Pilot Relay Type

Select Single Acting or Double Acting as the operation of the actuator.

### 4-2-3 Input Range

Sets the current input value when the valve travel is at 0% (Input Range Low (Close)) and the current input value when the valve travel is at 100% (Input Range High (Open)). An input in the 4–20 mA range can be used.  
Select [Device] → [Configuration] → [Input Range].

 <b>Cautions</b>	
	Changing the input signal range will move the valve, which is dangerous. Ensure ahead of time that there will be no injuries or effects on the processes if the valve is moved.

Input Range High (Open/100%): Set the input signal at 100% travel.



Input Range Low (Closed/0%): Set the input signal at 0% travel.

#### Handling Precautions:

- Set the current input span to not exceed 4 mA for (Input Range High (Open) - Input Range Low (Close)). If the current input span is less than 8 mA, the precision will be  $\pm 1.5\%$  of full scale.
- Set the value so that the operation direction is the same when the input signal is 0 mA and 4 mA. The following conditions must be satisfied.  
If the valve is fully closed at power-off :  
Input Range High (Open/100%) > Input Range Low (Closed/0%)  
If the valve is fully open at power-off :  
Input Range High (Open/100%) < Input Range Low (Closed/0%)

### 4-2-4 Valve System

Specify the operation of the control valve (actuator and valve) and the positioner.  
Select [Device] → [Configuration] → [Valve System].

 <b>Cautions</b>	
	It is dangerous because the valve moves when the settings are changed. Be prepared in advance to prevent injury and effects on the process when the valve moves.

- Actuator Type
  - Linear  
Linear motion valve
  - Rotary/90°  
When the distance between the feedback lever of the rotary actuator (90°) and the pin is longer than the distance from the valve shaft
  - Rotary/Other  
When the distance between the feedback lever of the rotary actuator (around 60°) and the pin is longer than the distance from the valve shaft
  - Rotary sub/90°  
When the distance between the feedback lever of the rotary actuator (90°) and the pin is shorter than the distance from the valve shaft

- Rotary sub/Other

When the distance between the feedback lever of the rotary actuator (around 60°) and the pin is shorter than the distance from the valve shaft

- Valve Closed Position

Feedback lever position of fully closed

- Down (Standard)
- Up

- Feedback Lever Motion

Specify UP or DOWN as the operation of the feedback lever when output air pressure OUT1 increases. This setting is automatically set by the auto setup.

- Pilot Relay Type

Pilot Relay Type (Single Acting or Double Acting) is indicated. The type is automatically determined by auto setup.

- Positioner Action

The EPM moving direction that is automatically determined by auto setup is indicated.

### **!** Handling Precautions:

The positioner operation direction is determined by the hardware of the main unit. This function cannot be used to switch the operation direction. If you want to switch the operation direction, contact one of our service representatives.

- Electrical Fail To

Open or Closed is automatically set as the fail safe direction when the electrical signal is “Disconnected” based on the settings for Valve Closed Position, Feedback Lever Motion, and Positioner Action.

- Air Fail To

Open or Closed is automatically set as the fail safe direction when the supply air pressure is “Disconnected” based on the settings for Valve Closed Position and Feedback Lever Motion.

This item is not displayed when Pilot Relay Type is Double Acting.

## **4-2-5 Control Configuration**

Control parameters are PID operation parameters for controlling the control valve and are selected based on Actuator Size and Friction Level.

Select [Device] → [Configuration] → [Control Configuration].

- Actuator Size

Specify Param 1 to 6 or Param A to C depending on the operation speed and capacity of the actuator.

To specify every PID operation parameter, select Custom. (For details, consult with one of our service representatives.)



Table 4-2 Actuator Size

Actuator Size	Operating speed [s]	Typical actuator model	Actuator capacity (Typical value) [cm <sup>3</sup> ]
PARAM C	Up to 0.25	-	200
PARAM B	Up to 0.35	-	300
PARAM A	Up to 0.45	-	400
PARAM 1	Up to 0.85	PSA1, PSK1	600
PARAM 2	Up to 2.0	PSA2, HA2	1400
PARAM 3	Up to 6.5	PSA3, HA3	2700
PARAM 4	Up to 8.15	PSA4, HA4	6600
PARAM 5	Up to 12	PSA6	8100
PARAM 6	Up to 99	VA5	25300

- Friction Level

Select Heavy, Medium, or Light depending on the gland packing. (It is not necessary to specify this item when Custom is selected for Actuator Size.)

Table 4-3 Friction Level

Friction Level *	Example of gland packing material
HEAVY	Graphite packing type
MEDIUM	Yarn packing type
LIGHT	V-type PTFE packing type

\* This value differs depending on the friction of the gland packing rather than the material.

- Control Deadband

Specify the deadband. Although deadband may be effective in preventing hunting, when the friction of the gland packing is especially large, for example, we recommend keeping this value within 1%.

- Replace Control Parameters

Replace the PID parameters selected in Actuator Size and Friction Level with the values in Control Parameters. The setting can be changed only if Actuator Size is set to Custom.

- Control Parameters

When Actuator Size is Custom, each PID must be specified individually.

The control algorithm employs dual GAP PID control, which switches PID parameters between three levels depending on the control deviation size. There are 11 parameters as shown below. Set a value larger than the dual width to the gap width. The integration operation is disabled when 9999 is set as the value of the integral.

P Outside of Gap:	Proportional gain outside the gap width [1/%]
I Outside of Gap:	Integral time outside the gap width [s]
D Outside of Gap:	Differential time outside the gap width [s]
Gap Band:	Gap width [±%]
P Inside Gap:	Proportional gain within the gap width [1/%]
I Inside Gap:	Integral time within the gap width [s]
D Inside Gap:	Differential time within the gap width [s]
Dual Gap Band:	Dual gap width [±%]
P Inside of Dual Gap:	Proportional gain within the dual gap width [1/%]
I Inside of Dual Gap:	Integral time within the dual gap width [s]
D Inside of Dual Gap:	Differential time within the dual gap width [s]

## 4-2-6 Input Characterization

Specify the flow amount characteristic.

Select [Device] → [Configuration] → [Input Characterization] → [InputCharacterization].

- Characterization

Select Linear, Equal Percent, Quick Open, or Custom Curve.

The concept of each characteristic is shown below.

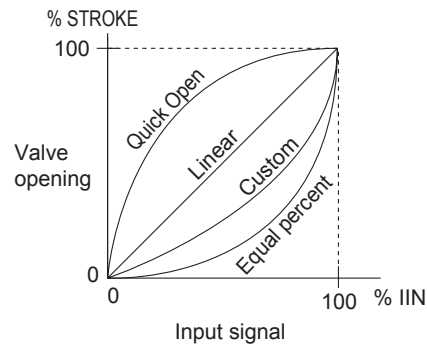

Figure4-2 Concept of Flow Characteristics

- Custom Curve Data

When selecting Custom Curve, individually specify the input signal (Custom Data X1 to 21) and the opening (Custom Data Y1 to 21) to specify a polygonal line consisting of 21 points.

### **!** Handling Precautions:

- Specify both Custom Data IN and Custom Data OUT so that they monotonically increase.
- The setting range is between 0% and 100%. The linear characteristic is set from both edges outside this range.

## 4-2-7 Travel Cutoff

Specify the input signal (%) to forcibly fully open or close the valve. The valve is fully closed when the input signal is less than or equal to the forced fully closed value. The valve is fully opened when the input signal is greater than or equal to the forced fully open value. These values can be independently specified.

Select [Device] → [Configuration] → [Travel Cutoff], then set forced fully closed value (TravelCutoff Low) and forced fully open value (Travel Cutoff High).

The concept of input/output characteristics when the forced fully open and closed values are specified is shown below.

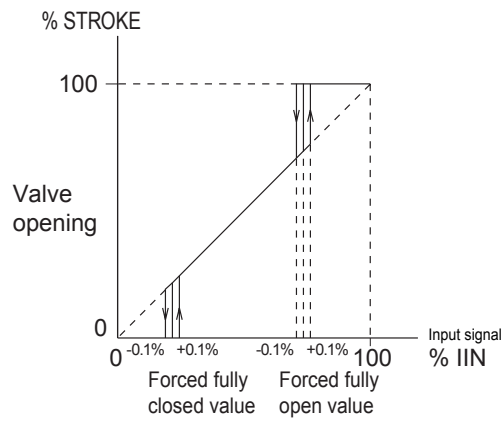

Figure4-3 Forced Fully Open and Closed Values

### ! Handling Precautions:

- Specify values such that the forced fully closed value is smaller than the forced fully open value.  
If the forced fully closed value is equal to the forced fully open value, the valve performs the ON/OFF operation.
- The settable range is between -200% and 50% for the forced fully closed value and between 50% and 200% for the forced fully open value.
- If you adjust the span after auto setup, the forced fully open value is automatically changed to the value calculated by subtracting 1% from the overstroke percentage.
- The forced fully closed and open values each have a hysteresis difference of 0.1%.
- When the valve is forced fully closed (open), Working Setpoint shows the value for the fully closed (open) status.

## 4-2-8 Units

Specify the units for pressure.

Select [Device] → [Configuration] → [Unit].

Initial setting of SI system unit and non-SI system unit is as follows. You can not change the initial setting.

If the non-SI system unit is needed, order kg/cm<sup>2</sup> or psi at the time of purchase.

SI system: kPa, MPa, Bar

Non-SI system: kPa, MPa, Bar, kg/cm<sup>2</sup>, PSI

This unit setting is invalid in the LUI display. Only the kPa is valid in the LUI display.

## 4-2-9 Travel Calibration

Adjust zero and span of valve opening.

Select [Device]→[Maintenance]→[Travel Calibration].

The following four types of zero span adjustment methods are available.

- (1) Auto Travel Calibration
- (2) Angle Correction
- (3) Manual Setting
- (4) Change Travel Angle

### Handling Precautions:

If you adjust the span after auto setup, the forced fully open value is changed to the value calculated by subtracting 1% from the overstroke percentage.

- (1) Auto Travel Calibration

When you select [Device]→[Maintenance]→[Travel Calibration]→[Auto Travel Calibration], the valve, which is initially fully closed, is fully opened and then fully closed, and the zero point and span point are automatically set.

### Cautions



It is dangerous during automatic opening adjustment because the fully opened valve moves to fully closed. Be prepared in advance to prevent injury and effects on the process when the valve moves.

### Handling Precautions:

- Set the input signal 5 mA min. If the input signal is below 5 mA, the device may not operate properly.
- If any of the self-diagnostic messages shown in Table 4-5 in 4-2-20, "Diagnostic Messages" appears, auto travel calibration cannot be executed.
- After device operation is performed, make sure Travel Cutoff of the valve with changing input signals.

- (2) Angle Correction

Adjust the angles of the zero and span points.

Select [Device]→[Maintenance]→[Travel Calibration]→[Angle Correction].

- 0% Travel

Set 0% to Final Valve.

Set a value less than 0% to Final Value Lo Cutoff, select the angle increment and decrement values, and adjust the zero point. (To increase the value by 0.01°, select Increment/0.01.)

After adjustment, return Final Value Lo Cutoff to the original value.

- 100% Travel

Set 100% to Final Valve.

If Final Value Hi Cutoff is less than 100%, set a value larger than 100%, select the angle increment and decrement values, and adjust the span point. After adjustment, return Final Value Hi Cutoff to its original value.

### **!** Handling Precautions:

If the angle after adjustment changes by more than  $\pm 30^\circ$ , the operation is disabled.

#### (3) Manual Setting

Manually fix the 0% or 100% opening and set the zero and span points.

Select [Device]→[Maintenance]→[Travel Calibration]→[Manual Setting].

- 0% Travel

Move the valve to the 0% opening position by operating the input signal, actuator pressure, manual handle, or other factor and set the zero point.

- 100% Travel

Move the valve to the 100% opening position by operating the input signal, actuator pressure, manual handle, or other factor and set the span point.

### **!** Handling Precautions:

If the angle after adjustment changes by more than  $\pm 30^\circ$ , the operation is disabled.

#### (4) Change Travel Angle

Set the angles of 0% opening and 100% opening.

The angle is  $0^\circ$  when the feedback lever is horizontal. The angle is negative if the lever is lower than the horizontal position. The angle is positive if the lever is higher than the horizontal position.

Select [Device]→[Maintenance]→[Travel Calibration]→[Change Travel Angle].

- 0% Travel Angle

Set the angle of the 0% opening position.

- 100% Travel Angle

Set the angle of the 100% opening position.

### **!** Handling Precautions:

Specify an angle within  $\pm 30^\circ$ . Accuracy is guaranteed between  $\pm 4^\circ$  and  $\pm 20^\circ$ .

## 4-2-10 Input Calibration

Calibrates the input signal (4 mA, 20 mA).

Select [Device] → [Maintenance] → [Input Calibration].

- Calibrate the 4 mA signal  
Set after making the current input (controller output) 4 mA.
- Calibrate the 20 mA signal  
Set after making the current input (controller output) 20 mA.

## 4-2-11 Pressure Sensor Adjustment

Adjust the zero point of the pressure sensor.

Select [Device] → [Maintenance] → [Pressure Sensor Adjustment] → [ZeroAdjustment].

Shut off the supply air pressure before zero adjustment.

## 4-2-12 Simulation

The following two operations can be changed.

### Handling Precautions:

The input signal should be 5 mA or more. If it is lower than 5 mA, the device does not operate normally.

#### (1) Dummy Input Signal

Specify the pseudo input signal (0% to 100%) and operate the valve. Regardless of the actual input current, the desired input signal can be sent to the device.

Select [Device] → [Maintenance] → [Simulation] → [Dummy Input Signal].

#### (2) Dummy Drive Signal

Specify the pseudo EPM drive signal (0% to 100%). Regardless of the actual input current and travel, the desired EPM drive signal can be output from the device.

Select [Device] → [Maintenance] → [Simulation] → [Dummy Drive Signal].

### Cautions



When a simulation is running, it is dangerous to leave it unused for more than 10 minutes, as this will cancel out the setting, and the valve may start moving. Ensure ahead of time that there will be no injuries or effects on process if the valve is moved.

### 4-2-13 Adjustment of EPM Drive Signal (Pneumatic Modules)

This function is used to adjust the EPM drive signal if the signal has shifted or if Positioner Action has changed.

Select [Device] → [Maintenance] → [Pneumatic Modules] → [EPM Adjustment].

#### Handling Precautions:

Ask our service representative for the operation not to damage a device by erroneous operation..

### 4-2-14 Restore factory settings

Restore the data that was set when the device was shipped from the factory.

Select [Device]→[Maintenance]→[Restore factory settings].

(It may be necessary to restart the communication tool after restoring the factory data.)

#### Handling Precautions:

This operation does not change the HART communication settings such as Device Tag and Long Tag, diagnostics-related settings, and history information.

### 4-2-15 Operator Action Records

Save the history of setting modification operations.

The operation item, operation method, and time of the last 10 modifications are saved.

Simulation operations are not saved.

Select [Device]→[Maintenance]→[Operator Action Records].

### 4-2-16 Real Time Clock

Checks and sets the current time.

Select [Device] → [Maintenance] → [Real Time Clock].

#### Handling Precautions:

The current time set with this operation is reset when the power is cut.  
(2012/04/01 00:000)

### 4-2-17 Password

Sets whether to use the password function and sets the password.

Select [Device] → [Maintenance] → [Password].

## 4-2-18 Device Information

Select [Device] → [Device Information].

The following information can be checked and the settings can be changed.

- **Manufacturer**  
Displays Azbil Corporation as the device manufacturer.
- **Model**  
Displays AVP700 as the name and model number of the device.
- **Device ID**  
Displays the unique ID information of the device.
- **Device Tag**  
Displays and changes the Tag No. assigned to the device.
- **Long Tag**  
Displays and changes the Tag No. assigned to the device.
- **Date**  
Displays and changes specific dates such as the final settings date of the device.
- **Descriptor**  
Displays and changes the various information required to manage the device.
- **Message**  
Displays and changes the messages registered in the device.  
Config Change Counter  
Displays and changes the messages registered in the device.
- **Serial Number**  
Displays the unique serial number of the device.
- **Final Assembly Number**  
Displays and changes specific management numbers such as the final settings date for the device and system.
- **Distributor**  
Displays the name of the company selling the device.
- **Config Change Counter**  
Displays the number of changes made to the set device.
- **Operating Time**  
Displays the time the device has been operating.
- **Polling Address**  
Displays and changes the device address. Specifies the device address when multiple devices are connected to the same loop (split range, multi-drop connection, etc.).



- Number of Request Preambles

Displays the number of preambles requested from the device to the host.

- Number of Response Preambles

Displays the number of preambles returned from the device to the host.

- Revision Numbers

HART Version:

Displays the revision number of the HART universal command supported by this device.

Device Revision:

Displays the revision number of the device-specific command supported by this device.

Software Revision:

Displays the revision number of the software in a given Device Revision.

Hardware Revision:

Displays the revision number of the hardware for this device.

- Factory Setting Information

Production Number:

Displays the production number.

Model Number:

Displays the model number.

Valve Model Number:

Displays the valve model number.

Factory Setting Date:

Displays the factory shipping date.

## 4-2-19 Option

Additional functions include the following.

### ■ Travel transmission signal output

Selecting [Device] → [Option] → [Travel Transmission (AO)] → [TravelTransmission] allows the travel signal output to be monitored.

Selecting [Device] → [Option] → [Travel Transmission (AO)] → [Dummy TravelTransmission] allows the travel signal output to be changed freely.

Selecting [Device] → [Option] → [Travel Transmission (AO)] → [Fail SafeDirection] allows the failsafe direction (High or Low) for the travel signal to be checked.

This setting is set at the time of factory shipment, and the setting change after the delivery is not possible.

If a self-diagnostic message pertaining to fail-safe operation (Table 4-5 in section 4-2-20) appears, the travel transmission signal is sent according to the specified fail safe direction.

Selecting [Device] → [Option] → [Travel Transmission (AO)] → [D/A Trim] calibrates the travel signal output (4 mA, 20 mA). Connect to an ammeter to calibrate the current value.

## 4-2-20 Diagnostic Messages

The device has a self-diagnostic function.

Select [Device]→[Diagnostics]→[Diagnostic Status]→[Positioner Diagnostic].

### 1) Self-Diagnostic Messages

Table 4-4 Self-Diagnostic Messages List

	Message
Failure	Valve Travel Detector Failure
	Valve Travel Detector Out of Range
	CPU Failure
	RAM Failure
	ROM Failure
	A/D Conversion Module 1 Failure
	A/D Conversion Module 2 Failure
	Non-Volatile Memory Failure
	Po 1 Pressure Sensor Failure
	Po 2 Pressure Sensor Failure
	Ps Pressure Sensor Failure
	Pn Pressure Sensor Failure
	Input Circuit Failure
	Temperature Sensor Failure
	Internal Program Execution Error
Function Check	In Use by Local User I/F
	Dummy Input Signal simulation is running
	Dummy Drive Signal simulation is running
	Dummy Travel Transmission simulation is running
	Auto Setup is running
	Auto Travel Calibration is running
	Step Responce Test is running
	Valve Signature is running
Out of Specification	VTD Angle Span Out of Range
	Input Signal Low
	Insufficient Input Signal Range
	Temperature Out of Range
	Supply Pressure Out of Range
	VTD Temperature Out of Range
	Incorrect Setting of Input Range High/Low
Maintenance Required	Restriction is clogged *
	Deposits on the Nozzle-Flapper *
Information	Travel Cutoff High
	Travel Cutoff Low
	Factory Settings Restored
	In Use by an Operator
	Local User I/F Abnormal
	Failure Output (AO)
	Local User I/F was used in past 10 min.

\* This message can be enabled or disabled by changing the setting of [Diagnostics] → [Diagnostic Setup] → [Positioner Air Circuit] → [Positioner Air Circuit Alarm Enabled]. The factory default setting is “Enabled.” (“Enabled” is recommended.)  
 In addition, you can set the threshold value of this message with [Diagnostics] → [Diagnostic Setup] → [Positioner Air Circuit] → [Drive Sig Shift Threshold +] or [Drive Sig Shift Threshold -]. The factory default setting is “±25 %.” (“±25 %” is recommended.)

**Self-diagnostic messages pertaining to fail-safe operation**

If the device judges, based on the result of self-diagnosis, that it cannot control the valve properly, the device executes fail-safe operation.

The output air pressure and Travel Transmission during fail-safe operation are as follows.

<Output air pressure>

Positioner Action	Pilot Relay Type	Output Air Pressure
Direct action	single acting	zero
	double acting	Po1: zero Po2: Supply Pressure
Reverse action	single acting	Supply Pressure
	double acting	double acting Po1: Supply Pressure Po2: zero

<Travel Transmission>

The travel transmission signal is output in accordance with the fail-safe direction (UP or DOWN) specified by a switch. (For how to check the setting, refer to 4-2-19, "Option.")

UP: 21.0 mA minimum

DOWN: 3.6 mA maximum

Fail-safe operation is executed if any of the following self-diagnostic messages appear.

Table 4-5 Self-diagnostic messages leading to fail-safe operation

Message
Valve Travel Detector Failure
Valve Travel Detector Out of Range
CPU Failure
RAM Failure
ROM Failure
A/D Conversion Module 1 Failure
Non-Volatile Memory Failure
Input Circuit Failure

## 4-2-21 Control Valve Diagnostic Messages

The device has a control valve diagnostic function. Select [Device]→[Diagnostics]→[Diagnostic Status]→[Valve Diagnostic].

Table 4-6 Control Valve Diagnostic Messages List

	Message
Out of Specification	Supply Pressure High Alarm
	Supply Pressure Low Alarm
	Temp High Alarm
	Temp Low Alarm
	Deviation + Alarm
	Deviation - Alarm
	Zero Travel + Alarm
	Zero Travel - Alarm
	Maintenance Required
Cycle Count Alarm	
Shut Count Alarm	
Max Tvl Speed + Alarm	
Max Tvl Speed - Alarm	
Po Validity + Alarm	
Po Validity - Alarm	
Max Friction Alarm	
Stick-Slip High Alarm	
Stick-Slip Medium Alarm	
Stick-Slip Low Alarm	



# Chapter 5 Troubleshooting

This chapter describes how to address problems in case of troubles.

The following three types of problems may occur when you start up and start operating the device.

- Problems that occur because the specifications of the device are not suitable for the actual use conditions
- Problems due to setup or operation errors
- Problems due to failure of the device

If a problem occurs, take appropriate actions according to the troubleshooting guidelines described in this chapter.

## 5-1 Troubleshooting

If a problem occurs when operation starts or during operation, address the problem according to the procedure below. If the problem cannot be solved after taking the actions described below, the device may be malfunctioning. Please contact us.

### 5-1-1 The Device Does Not Operate. (There Is No Output Air Pressure.)

1. Check that setup has been properly completed (e.g. allowable rotation angle of feedback lever).
2. Check that an appropriate supply air pressure is supplied (e.g. air leak).
3. Check that an appropriate input signal (power supply) is input (e.g. whether electrical wiring is correct).
4. When communication is possible, have the device perform self-diagnostics and take actions according to the displayed messages. Please refer to 5-2, "Description of Messages."
5. Check whether the internal data in the device is properly specified.

### 5-1-2 The Control Valve Operates Abnormally (There Is Output Air Pressure.)

1. Activate the manual operation status with the A/M switch, adjust air with the regulator, and check that the valve shaft moves smoothly. (Check whether galling or packing solidification has occurred.)
2. Check whether the internal data in the device is properly specified (actuator size and hysteresis, among other data).
3. If the symptoms of the problem can be found in the table below, take the corresponding actions according to the table.

Problem	Point to be checked and action
Hunting Overshoot	<ul style="list-style-type: none"><li>- Check that the allowable rotation angle of the feedback lever is obeyed.</li><li>- Change the friction level from Light to Medium to Heavy. If this does not solve the problem, change the actuator size setting to a smaller parameter with the friction level set to Heavy. (For the work procedure, refer to "Adjustment Procedure when Hunting Occurs" on the next page.)</li></ul>
The device does not complete a full stroke. The response speed is too slow.	<ul style="list-style-type: none"><li>- Check that the fully closed and open positions (zero and span) of the valve are properly adjusted.</li><li>- Check that the EPM drive signal is within the range of <math>50 \pm 25\%</math>.</li></ul>

### 5-1-3 Failure to communicate with the communicator

1. Check whether the electrical wiring is correct.
2. Check whether the communicator is correctly connected with the device.
3. Check whether both input and output devices have power sources.
4. Check whether the relationship between the power supply voltage and external load meets the specifications.
5. Check whether the wiring is correct for the Models without the motion transmission function (model AVP702) and with the motion transmission function (model AVP701)



### 5-1-4 Adjustment Procedure When Hunting Occurs

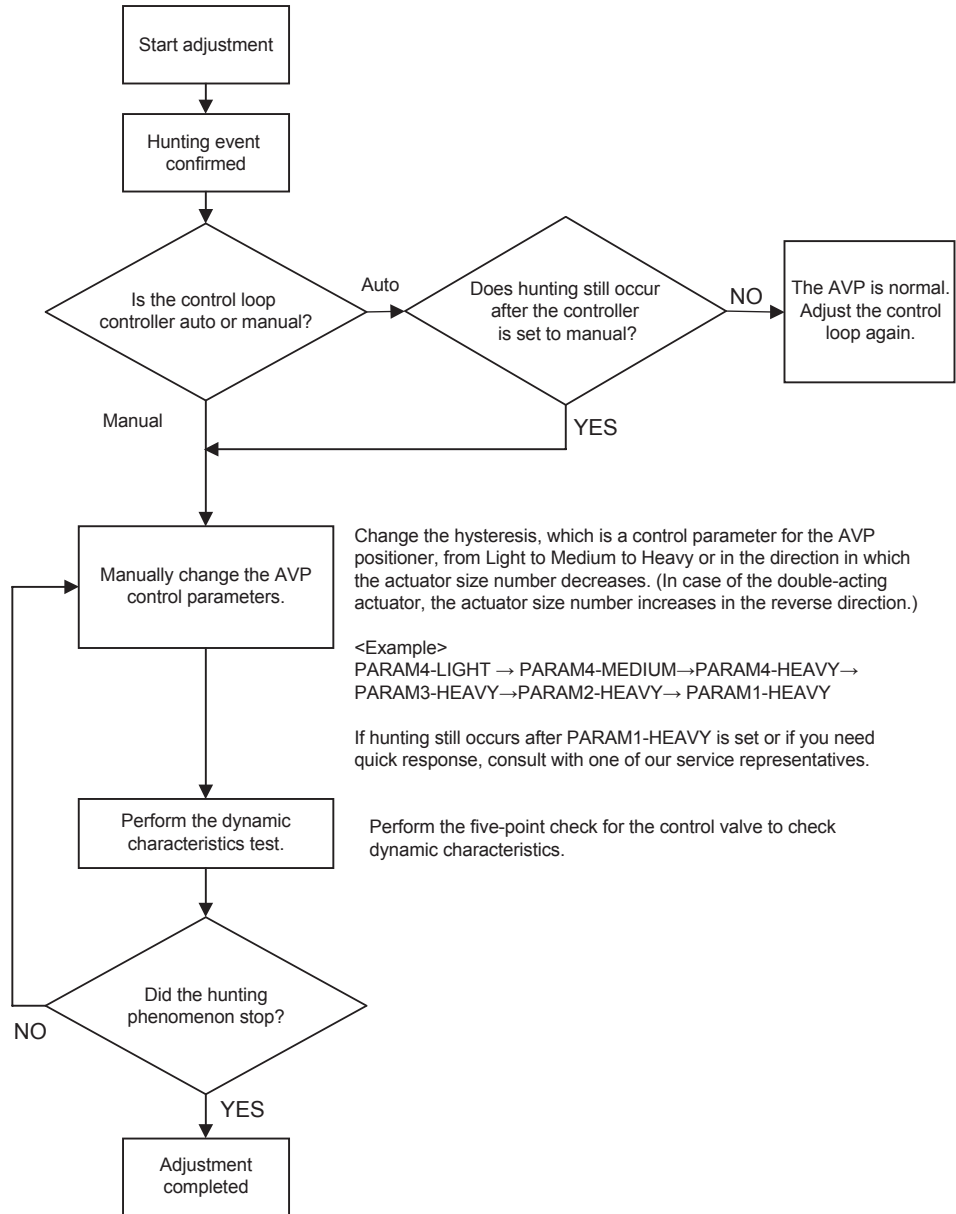

Figure 5.1

## 5-1-5 Auto Setup Failure

Check the following:

- The supply air pressure is appropriate.
- The A/M switch is in the AUTO position.
- The feedback pin and feedback lever are properly connected.
- The output air pressure is properly supplied to the actuator.
- Valve motion is not obstructed by a handle, etc.
- The input signal is 5 mA or more.
- Valve Signature and Step Response Test are not running.

If there is no problem with the above, there is a possibility that the attached actuator cannot be set up using the auto setup function for some reason. For example, the actuator may take too long before starting to operate. In this case, the user can set up the device manually in order to control valve travel properly. However, some functions will be unavailable.

- Some types of valve diagnosis cannot be used. (For details, contact our service staff.)
- Deviation diagnosis when the valve is forced to open might not work properly.









### **Settings necessary for travel control**









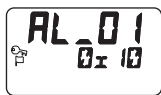



Specify the parameters in the table below, referring to the indicated sections of the manual.

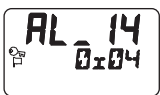





Type	Parameter	Reference	
		LUI	HART Communication
Control valve system settings	Valve Closed Position	3-2-1 (3)	4-2-4
	Actuator Type	3-2-1 (3)	4-2-4
	Feedback Lever Motion	Cannot be specified using the LUI.	4-2-4
Zero/span adjustment	Travel Angle 0 %	3-2-2 (3)	4-2-9 (3) or 4-2-9 (4)
	Travel Angle 100 %		
Control parameter settings	Actuator Size	3-2-4	4-2-5
	Fricition Level		
Input signal range settings*	Input Range Low	Cannot be specified using the LUI.	4-2-3
	Input Range High		



\* These parameters must be changed if their magnitude relationship is not correct.

## 5-2 Description of Messages

Message	LUI display example *1	LUI display		Description and cause	Action
		Upper part	Lower part [*: Optional]		
ROM Failure		AL_00	0x01,0x03,0x05,0x07 0x09,0x0b,0x0d,0x0F	ROM error.	Contact Azbil group.
RAM Failure		AL_00	0x02,0x03,0x06,0x07 0x0A,0x0b,0x0E,0x0F	RAM error.	Contact Azbil group.
Non-Volatile Memory Failure		AL_00	0x04,0x05,0x06,0x07 0x0c,0x0d,0x0E,0x0F	Non-volatile memory error.	Contact Azbil group.
CPU Failure		AL_00	0x08,0x09,0x0A,0x0b 0x0c,0x0d,0x0E,0x0F	CPU error.	Contact Azbil group.
Valve Travel Detector Failure		AL_01	0x*1,0x*5,0x*9,0x*d	VTD (angle sensor) error. - The VTD connector is disconnected. - VTD signal line is disconnected or short-circuited.	Contact Azbil group.
Valve Travel Detector Out of Range		AL_01	0x*2,0x*6,0x*A,0x*E	VTD (angle sensor) output error. - The allowable rotation angle of feedback lever ( $\pm 30^\circ$ ) is exceeded. - The feedback lever is disengaged.	Check that the feedback lever is not disengaged and that the allowable rotation angle ( $\pm 30^\circ$ ) is obeyed. If the error message does not disappear even after you check these points, contact us.
A/D Conversion Module 1 Failure		AL_01	0x*4,0x*5,0x*6,0x*c 0x*d,0x*E	Error in the AD conversion section (operation part).	Contact Azbil group.
A/D Conversion Module 2 Failure		AL_01	0x*8,0x*9,0x*A,0x*c 0x*d,0x*E	Error in the AD conversion section (pressure sensor).	Contact Azbil group.
Input Circuit Failure		AL_14	0x*1,0x*3,0x*5,0x*7 0x*9,0x*b,0x*d,0x*F	Input Circuit Failure	Contact Azbil group.
Po 1 Pressure Sensor Failure		AL_01	0x1*,0x3*,0x5*,0x7* 0x9*,0xb*,0xd*,0xF*	Error in the Po1 pressure sensor.	Contact Azbil group.

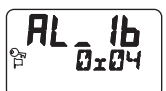
Message	LUI display example *1	LUI display		Description and cause	Action
		Upper part	Lower part [: Optional]		
Po 2 Pressure Sensor Failure		AL_01	0x2*,0x3*,0x6*,0x7* 0xA*,0xB*,0xE*,0xF*	Error in the Po2 pressure sensor.	Contact Azbil group.
Ps Pressure Sensor Failure		AL_01	0x4*,0x5*,0x6*,0x7* 0xc*,0xd*,0xE*,0xF*	Error in the Ps pressure sensor.	Contact Azbil group.
Pn Pressure Sensor Failure		AL_01	0x8*,0x9*,0xA*,0xB* 0xc*,0xd*,0xE*,0xF*	Error in the Pn pressure sensor.	Contact Azbil group.
Temperature Sensor Failure		AL_14	0x02,0x03,0x06,0x07 0x0A,0x0b,0x0E,0x0F	Temperature sensor error.	Contact Azbil group.
Internal Program Execution Error		AL_14	0x04,0x05,0x06,0x07 0x0c,0x0d,0x0E,0x0F	Program execution error.	Contact Azbil group.
Local User I/F Active	—	—	—	The LUI is operating (in setup mode).	Exit the LUI setup mode by holding down  .
Dummy Drive Signal simulation is running		AL_02	0x*8,0x*9,0x*A,0x*b	The device is in the pseudo EPM drive signal output state.	Clear the pseudo EPM drive signal output state.
Auto Setup is running		AL_02	0x1*	Auto setup is being performed.	Wait until execution ends or stop it with the stop command as needed.
Auto Travel Calibration is running		AL_02	0x2*	Automatic opening adjustment is being performed.	Wait until execution ends or stop it with the stop command as needed.
Step Responce Test is running		AL_02	0x4*	The step response test is being performed.	Wait until execution ends or stop it with the stop command as needed.
Valve Signature is running		AL_02	0x8*	Valve signature is being performed.	Wait until execution ends or stop it with the stop command as needed.
VTD Angle Span Out of Range		AL_03	0x*1,0x*3,0x*5,0x*7 0x*9,0x*b,0x*d,0x*f	The zero and span range is too narrow.	Adjust the zero and span so that the angle of the feedback lever has a span of 4° or larger.

Message	LUI display example *1	LUI display		Description and cause	Action
		Upper part	Lower part [: Optional]		
Input Signal Low		AL_03	0x*2,0x*3,0x*6,0x*7 0x*A,0x*b,0x*E,0x*F	The input current is too low.	Input at least 3.5mA
Insufficient Input Signal Range		AL_03	0x*4,0x*5,0x*6,0x*7 0x*c,0x*d,0x*E,0x*F	The input signal range is too narrow.	Set the input signal span more than 2mA.
Temperature Out of Range		AL_03	0x*8,0x*9,0x*A,0x*b 0x*c,0x*d,0x*E,0x*F	The temperature in the device is lower than -40° or higher than 80°.	Set the ambient temperature to between -40° and 80° as specified by the usage conditions. If this message is displayed even though this condition is satisfied, a sensor error is suspected. Contact Azbil group.
Supply Pressure Out of Range		AL_03	0x1*,0x5*	The supply air pressure detected in the device is lower than 50 kPa or higher than 715 kPa.	<ul style="list-style-type: none"> <li>- Check that the supply air pressure is applied.</li> <li>- Set the supply air pressure to 715 kPa or lower. If this message is displayed even though this condition is satisfied, a sensor error is suspected. Contact Azbil group.</li> </ul>
Incorrect Setting of Input Range High/Low		AL_03	0x4*,0x5*	The high and low setting of the input signal range are incorrect.	Make sure the settings of Input Range High (Open) and Input Range Low (Closed).
Supply Pressure High Alarm		AL_16	0x01,0x05,0x09	The supply air pressure is higher than the specified threshold value.	<ul style="list-style-type: none"> <li>- Check the supply air pressure.</li> <li>- Check that the threshold value is appropriate.</li> </ul>
Supply Pressure Low Alarm		AL_16	0x02,0x06,0x0A	The supply air pressure is lower than the specified threshold value.	
Temp High Alarm		AL_16	0x04,0x05,0x06	The internal temperature is higher than the specified threshold value.	<ul style="list-style-type: none"> <li>- Check the ambient temperature.</li> <li>- Check that the threshold value is appropriate for the usage environment.</li> </ul>

Message	LUI display example *1	LUI display		Description and cause	Action
		Upper part	Lower part [*: Optional]		
Temp Low Alarm		AL_16	0x08,0x09,0x0A	The internal temperature is lower than the specified threshold value.	<ul style="list-style-type: none"> <li>- Check the ambient temperature.</li> <li>- Check that the threshold value is appropriate for the usage environment.</li> </ul>
Restriction is clogged		AL_04	0x01	<p>The EPM drive signal has exceeded the normal operation range.</p> <ul style="list-style-type: none"> <li>- The fixed diaphragm is clogged.</li> <li>- Air is not supplied.</li> <li>- The valve shaft is galled.</li> </ul>	<ul style="list-style-type: none"> <li>- Clean the fixed flow restriction.</li> <li>- Check the supply air pressure.</li> <li>- Check the EPM drive signal.</li> <li>- Change the input signal to confirm seamless operation.</li> </ul> <p>(- Perform auto setup.)</p>
Deposits on the Nozzle-Flapper		AL_04	0x02	<p>The EPM drive signal has exceeded the normal operation range.</p> <ul style="list-style-type: none"> <li>- The nozzle is clogged.</li> <li>- The A/M switch is in manual mode.</li> </ul>	<ul style="list-style-type: none"> <li>- Clean the nozzle.</li> <li>- Check that the A/M switch is in auto mode.</li> <li>- Check the EPM drive signal.</li> <li>- Change the input signal to confirm seamless operation.</li> </ul>
Total Stroke Alarm	—	—	—	The cumulated sliding distance is larger than the threshold value.	Check the operation of the control valve.
Cycle Count Alarm	—	—	—	The number of inversion operations is larger than the threshold value.	Check the operation of the control valve.
Shut Count Alarm	—	—	—	The number of fully closing operations is larger than the threshold value.	Check the operation of the control valve.
Max Tvl Speed + Alarm	—	—	—	The maximum operation speed + is larger than the threshold value.	Check the operation of the control valve.
Max Tvl Speed - Alarm	—	—	—	The maximum operation speed - is smaller than the threshold value.	Check the operation of the control valve.

Message	LUI display example *1	LUI display		Description and cause	Action
		Upper part	Lower part [*: Optional]		
Po Validity + Alarm	—		—	The output air pressure validity + is larger than the threshold value.	Check the operation of the control valve.
Po Validity - Alarm	—		—	The output air pressure validity - is smaller than the threshold value.	Check the operation of the control valve.
Max Friction Alarm	—		—	The maximum friction is larger than the threshold value.	Check the operation of the control valve.
Stick-Slip High Alarm	—		—	Stick-slip is larger than the “High” threshold value.	Check the operation of the control valve.
Stick-Slip Medium Alarm	—		—	Stick-slip is larger than the “Medium” threshold value.	Check the operation of the control valve.
Stick-Slip Low Alarm	—		—	Stick-slip is larger than the “Low” threshold value.	Check the operation of the control valve.
Deviation + Alarm	—		—	The deviation + is larger than the threshold value.	Check the operation of the control valve.
Deviation - Alarm	—		—	The deviation - is smaller than the threshold value.	Check the operation of the control valve.
Zero Travel + Alarm	—		—	The zero point opening + is larger than the threshold value.	Check the operation of the control valve.
Zero Travel - Alarm	—		—	The zero point opening - is smaller than the threshold value.	Check the operation of the control valve.
Travel Cutoff High	—		—	The valve was forcibly fully opened.	Check the forced fully open and closed values and apply the input signal within the setting range.
Travel Cutoff Low	—		—	The valve was forcibly fully closed.	
Factory Settings Restored	—		—	The data set when the device was shipped from the factory was restored. The factory data restoration (Restore factory settings) operation was performed.	Perform appropriate adjustment and setup.
In Use by an Operator	—		—	Settings are being changed through HART communication or with the LUI.	Check who the operator is that is changing the settings.

Message	LUI display example *1	LUI display		Description and cause	Action
		Upper part	Lower part [*: Optional]		
Local User I/ F Abnormal	—		—	LUI module error. Key input is still recognized as ON. The key is being physically pressed down.	Check the key status. Move the device away from any nearby strong magnetic field.
Local User I/ F was used in past 10 min.	—		—	The LUI key was operated within the past 10 minutes.	There may be someone near the device. Check the safety in the field.



\*1: These alarms are displayed with the normal monitor. The alarms are not displayed with other monitors.



## Chapter 6 Maintenance

This chapter describes periodic maintenance for the device. You can properly use the device by performing appropriate maintenance. In addition, the limited life parts are listed as resale parts in 6-8. Because the replacement frequencies of resale parts differ depending on the usage environment and usage situation of the device, specify appropriate replacement frequencies.

### Precautions for safe work

 <b>Cautions</b>	
	If appropriate maintenance is not performed, an unexpected operation may cause the feedback lever to move, causing an injury. Perform maintenance at appropriate times.
	Maintenance work is dangerous because the valve moves. Be prepared in advance to prevent injury and effects on the process when the valve moves.

## 6-1 A/M Switch

The maintenance work can be performed by switching between Auto and Manual. The device has a built-in Auto/Manual (A/M) switch.

The A/M switch switches the control method of output air from the positioner between auto operation and manual operation.

### 1) Auto operation

- The device outputs the output air pressure to control the opening according to the input signal.

### 2) Manual operation

- The positioner directly outputs the supply air pressure.
- Manual operations with the regulator are possible. (The double-acting actuator does not support manual operation.)

#### **Warning**



It is dangerous because the valve moves when the A/M switch is operated. Be prepared in advance to prevent injury and effects on the process when the valve moves.

### 3) Structure of A/M switch

The structure of the A/M switch is shown in the figure below.

Remove the pilot relay cover.

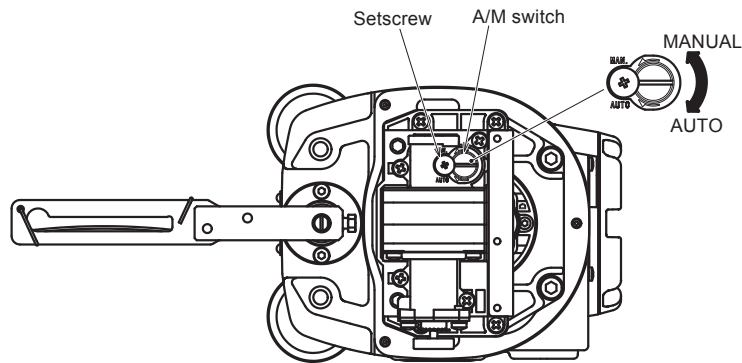

Figure 6-1 Structure of A/M Switch

<b>⚠ Cautions</b>	
	Do not loosen the setscrew. If the setscrew is loosened, the A/M switch will pop out due to the air pressure, potentially causing an injury.

### 4) Procedure for switching from auto operation to manual operation

The procedure for switching from auto operation to manual operation is shown below.

Step	Work
1	Loosen the three screws to remove the pilot relay cover in order to operate the A/M switch.
2	Rotate the A/M switch counterclockwise (in the MAN direction) by one revolution using a flat-head screwdriver. (Confirm that operation has switched by using the output air pressure gauge.)

### 5) Procedure for switching from manual operation to auto operation

The procedure for switching from auto operation to manual operation is shown below.

Step	Work
1	Securely rotate the A/M switch clockwise (in the AUTO direction) using a flat-head screwdriver until it stops. (Confirm that operation has switched by using the output air pressure gauge.)
2	Attach the pilot relay cover onto the main unit with the three screws.

## 6-2 Replacement of Filter and Maintenance of Flow Restriction

The contamination of the flow restriction section in the device caused by instrumentation air can be removed during maintenance. The replacement and maintenance procedures are described below.

### **!** Handling Precautions:

Use clean dry air with solid particles no larger than 3- $\mu$ m as the instrumentation air.

Step	Work
1	Shut off the supply air to the device.
2	Loosen the three screws to remove the pilot relay cover and remove the setscrew in the A/M switch section.
3	Rotate the A/M switch in the MAN direction to remove.
4	Cut the holder with nippers or other tool to remove the old filter.  <b>!</b> Handling Precautions: Properly dispose of the old holder and filter.
5	Clean the flow restriction section using a wire (with a diameter of 0.25 mm) or other tool.  <b>!</b> Handling Precautions: When cleaning, be careful not to damage the hole of the flow restriction. Do not use an air gun. Be careful not to let oil get on the cleaned flow restriction again.
6	Wrap a new filter around the A/M switch and hold it with the holder.
7	Screw in the A/M switch until it stops.
8	Screw the setscrew into the A/M switch section.
9	Attach the pilot relay cover with the three screws.

## 6-3 Cleaning the Flapper

If the flapper is contaminated by instrumentation air, clean it as described below.

### Cautions



If air pressure is supplied to the device, the back pressure of the nozzle changes after the flapper is cleaned, and therefore, the valve opening suddenly changes. Perform cleaning under conditions where the sudden move of the valve will not injure people or disturb plant operation.

Step	Work
1	Remove the three screws from the pilot relay cover.
2	Prepare a piece of 0.2-mm thick paper. A typical business card is appropriate.
3	Chip dirt that has accumulated in the space between the nozzle and flapper in the EPM away with the paper.
4	After cleaning, attach the pilot relay cover to the main unit with the three screws.

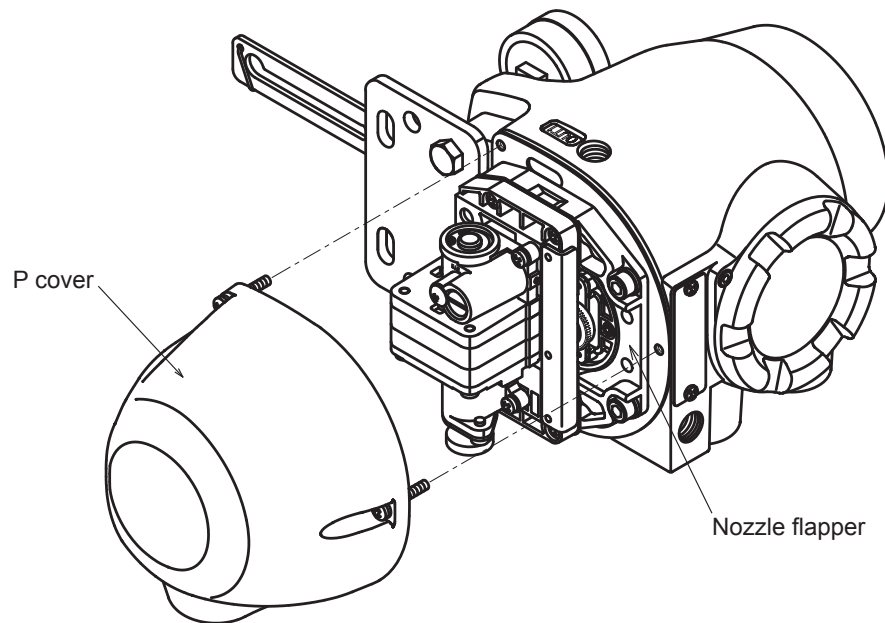





Figure 6-2 Structure

## 6-4 Adjusting the Pilot Relay

The adjustment method for the pilot relay differs depending on whether the single-acting or double-acting actuator is used.

Perform adjustments suitable for the actuator being used by referring to the procedures described below.

 <b>Cautions</b>	
	When rotating the pilot relay adjustment screw, be careful not to get your finger caught in the space between it and the adapter.
	The adjustment screw may be damaged if you rotate it with excessive force by using a tool.



### 1) Procedure for adjusting the pilot relay for the double-acting actuator (Adjustment from single-acting type to double-acting type)

Step	Work
1	<p>Rotate the pilot relay adjustment screw clockwise (tightening direction) until it stops.</p> <p>The balance pressure of output air pressures Pout1 and Pout2 is used as the supply air pressure.</p>
2	<p>Perform auto setup. (Use the LUI or communication.)</p> <p>Auto setup configures the double-acting settings and roughly adjusts the zero span.</p> <p>If auto setup fails, refer to 5-1-5, "Auto Setup Failure" to solve the problem. If there is still a problem and auto setup cannot be completed, Pilot Relay Type will not be changed to Double Acting and the pilot relay cannot be used for a double-acting actuator. In this case please stop adjustment and contact us.</p>
3	<p>After confirming that auto setup is completed, apply the input signal to make the opening 50%.</p>
4	<p>While checking output air pressure Pout1 or Pout2 with the LUI or pressure gauge, rotate the pilot relay adjustment screw to adjust the output air pressure to <math>70\% \pm 10\%</math> of the supply air pressure.</p> <p>Rotating the adjustment screw clockwise increases the balance pressure while rotating it counterclockwise decreases the balance pressure.</p> <p> <b>Handling Precautions:</b></p> <p>If the actuator has a large capacity, it takes time for the balance pressure to stabilize. Rotating the adjustment back a bit facilitates stabilization.</p>
5	<p>Perform auto setup again.</p> <p>The final adjustment value is measured.</p>
6	<p>Perform operation checks including a five-point check (0, 25, 50, 75, 100% opening).</p>

2) Procedure for adjusting the pilot relay for the single-acting actuator  
(Adjustment from double-acting type to single-acting type)

Step	Work
1	Rotate the pilot relay adjustment screw counterclockwise (loosening direction) until it stops. Output air pressure Pout2 becomes 0.
2	Perform auto setup. If auto setup fails, refer to 5-1-5, "Auto Setup Failure" to solve the problem. If there is still a problem and auto setup cannot be completed, Pilot Relay Type will not be changed to Single Acting and the pilot relay cannot be used for a single-acting actuator. In this case please stop adjustment and contact us.
3	Perform operation checks including a five-point check (0, 25, 50, 75, 100% opening).

## 6-5 Insulation Resistance Test

 <b>Cautions</b>	
	In principle, do not perform the insulation resistance test. This test may damage the built-in varistor for absorbing surge voltage. If it is absolutely necessary to perform this test, carefully follow the specified procedure.

1) Test procedure

- Remove external wiring from the device.
- Short-circuit the FB input signal terminals + and -.
- Perform the test between each of the short-circuited parts and the grounding terminal.
- The applied voltage and evaluation criteria are as shown in the table below.

 **Handling Precautions:**

Do not apply a voltage equal to or higher than the value below to prevent the instrument from being damaged.

2) Evaluation criteria

The evaluation criteria for this test is as shown below.

Test	Evaluation criteria
Insulation resistance	$2 \times 10^7 \Omega$ or higher at a test voltage of 25 VDC (at 25°C, 60%RH or less)

## 6-6 Adjustment Procedure When Using the Device with the Booster Relay Attached

When using the device with the booster relay attached, perform adjustment according to the following procedure.

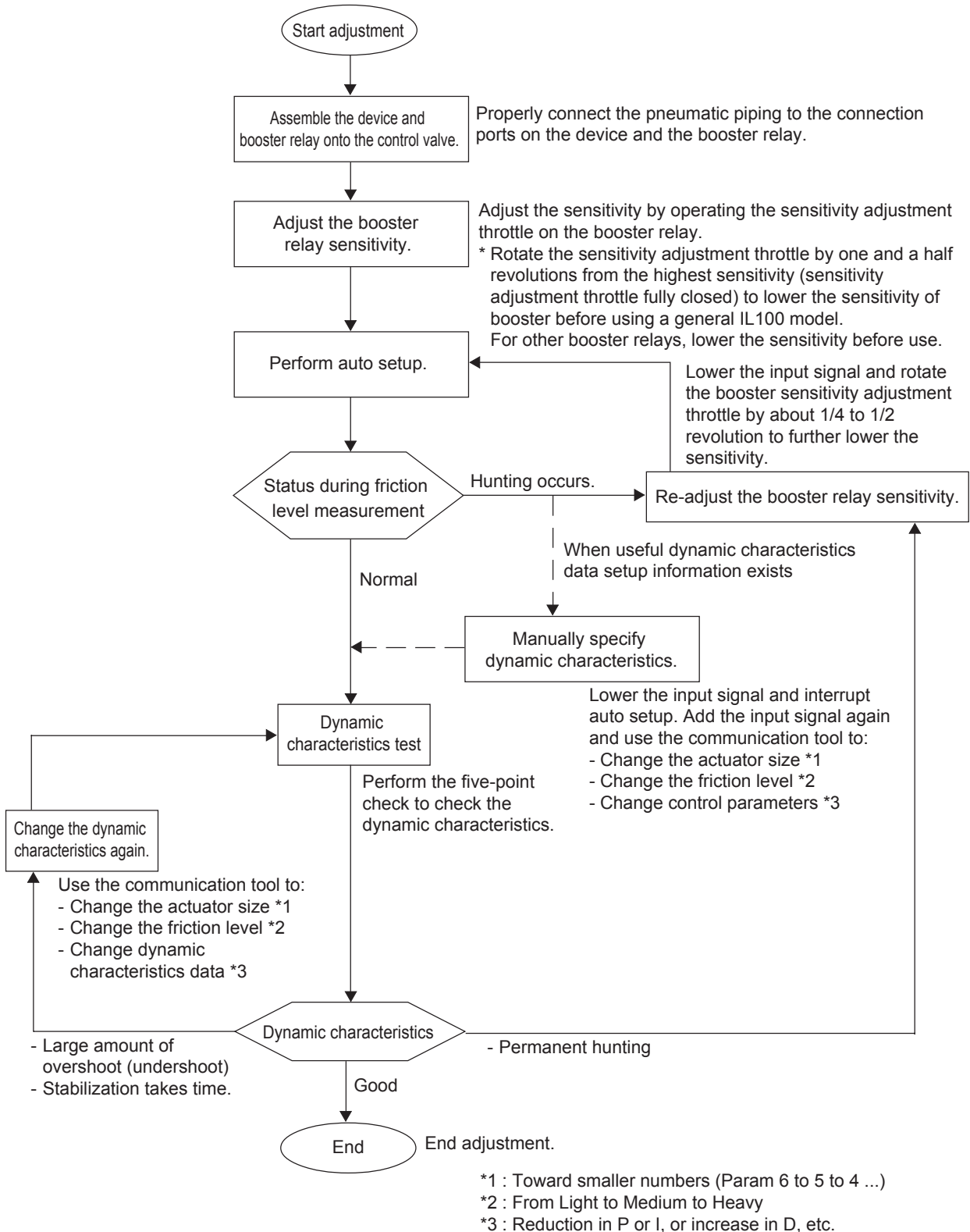

Figure 6-3



## 6-7 List of Default Values for Internal Data

Item	Parameter	Default	
Device tag	Device Tag	XXXXXXXX	
Long tag	Long Tag	Number of characters: 32	
Input value to fully open the valve	Input Range High (Open)	20mA	
Input value to fully close the valve	Input Range Low (Close)	4mA	
Actuator type	Actuator Type	Linear	
Position of valve when fully closed	Valve Closed Position	FeedBack Lever Down	
Whether a booster relay is provided	Booster relay	Without Booster Relay	
Feedback lever operation	Feedback Lever Motion	UP when Po1 increases	
Pilot relay type	Pilot Relay Type	Single Acting	
Positioner operation	Positioner Action	Direct	
Electrical fail direction	Electrical Fail to	Close	
Actuator size	Actuator Size	Param 1	
Friction level	Friction Level	Heavy	
Control deadband	Control Deadband	0.05	
Controlled parameter	Proportional gain (beyond GAP1)	P out of GAP1	1
	Integral time (beyond GAP1)	I out of GAP1	10
	Differential time (beyond GAP1)	D out of GAP1	0.2
	GAP width 1	GAP1	5
	Proportional gain (within GAP1)	P inside of GAP1	0.5
	Integral time (within GAP1)	I inside of GAP1	5
	Differential time (within GAP1)	D inside of GAP1	0.2
	GAP width 2	GAP2	1
	Proportional gain (within GAP2)	P inside of GAP2	0.2
	Integral time (within GAP2)	I inside of GAP2	2
	Differential time (within GAP2)	D inside of GAP2	0.2
Flow amount characteristic	Input Characterization	Linear	
Forced fully open value	Travel Cutoff High	109	
Forced fully closed value	Travel Cutoff Low	0.5	
Pressure display unit	Unit of Pressure	kPa	

## 6-8 Internal Block Diagram of the 700 Series

### 1) Internal block diagram of the 700 Series

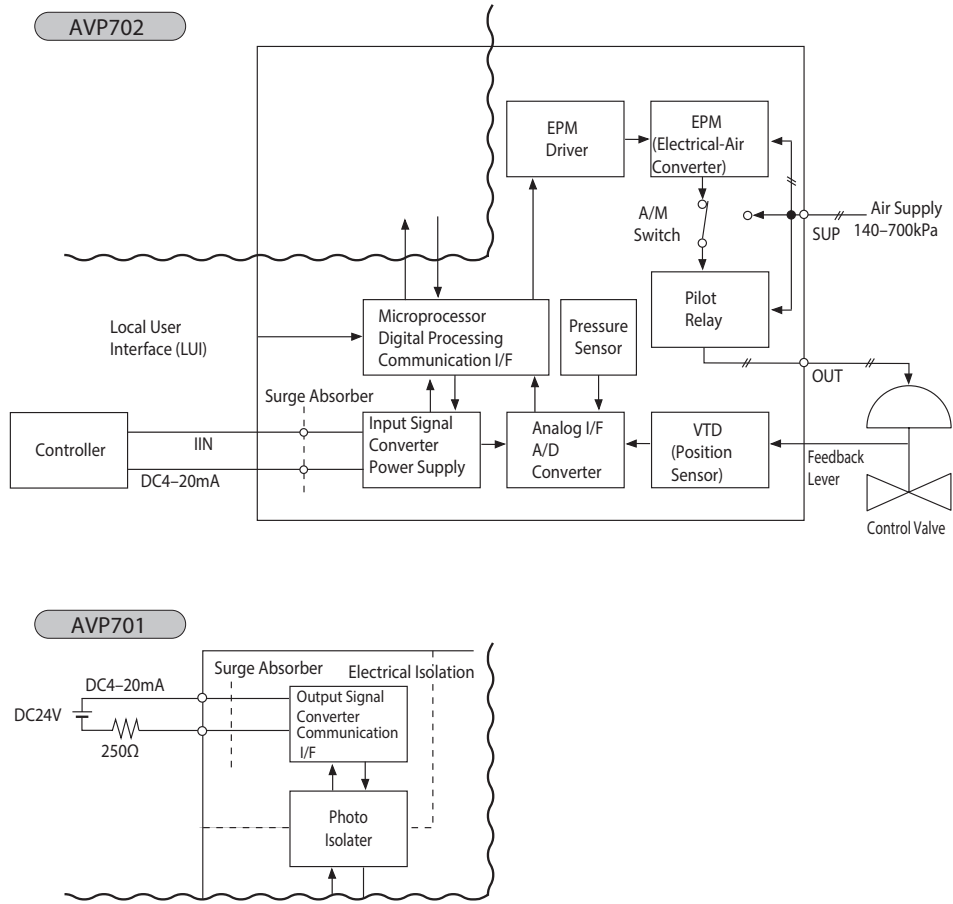

Figure 6-4

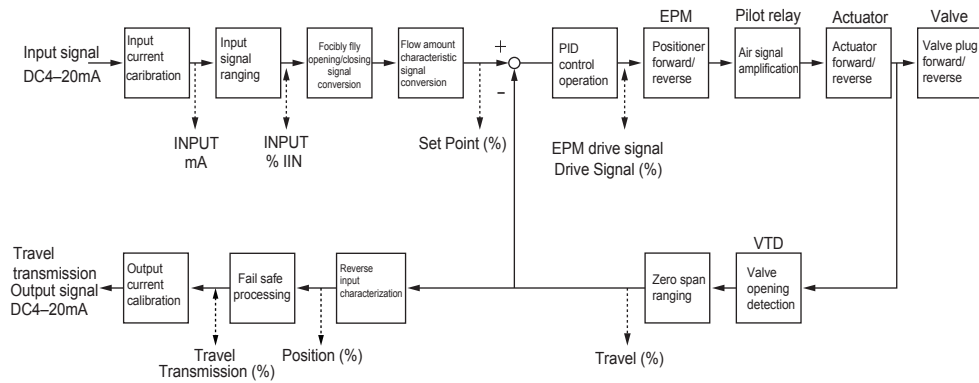

Figure 6-5

## 6-9 Resale Parts

The resale parts for maintenance are listed in the table below. For the position of each part, refer to Figure 6-6.

No.	Name	Part no.	Qty.	Recommended replacement period (year)*1	Recommended tightening torque N·m
1	Face cover assembly	80388840-101	1	-	0.9 ± 0.1
2	Face cover	80388841-001	1	-	-
3	Hexagon socket flush bolt (for face cover, M4×16)	80388843-101	2	-	0.9 ± 0.1
4	Screw retainer ring (for face cover)	80235519-010	2	-	-
5	Switch block assembly	80388910-901	1	5	1.02 ± 0.33
6	S-TITE (for switch block, equivalent to M3×6)	80388918-001	2	-	1.02 ± 0.33
7	Terminal cover assembly	80388820-001 (finish S) 80388820-002 (finish B) 80388820-003 (finish D)	1	5	-
8	O-ring (AS568-151) (for terminal cover)	803888281-151	1	5	-
9	Hexagon socket bolt (lock screw for terminal cover, M4×8)	314-204-080	1	-	0.9 ± 0.1
10	Set of five cross recessed head screws with captive spring washers (terminal screw, M4×8)	80277581-001	5	-	1.5 ± 0.2
11	Cross recessed head screws with captive spring washers (external grounding terminal screw, M4×8)	80277581-001	1	-	1.5 ± 0.2
12	Exhaust cap	80388823-001 (finish S) 80388823-002 (finish B) 80388823-003 (finish D)	1	-	-
13	S-TITE (equivalent to M3×6) (for exhaust cap)	80388918-001	2	-	1.33 ± 0.46
14	P cover assembly (with screw)	80388825-001 (finish S) 80388825-002 (finish B) 80388825-003 (finish D)	1	-	1.5 ± 0.2
15	Special cross recessed head screws with captive spring washers (for P cover, M4×16, shank: 9)	80388844-001	3	-	1.5 ± 0.2
16	Seal washer (for P cover)	80357789-001	3	-	-
17	Pilot relay assembly (including the A/M screw assembly)	80388850-001 (single acting) 80388850-002 (double acting)	1	5	-
18	Cross recessed head screws with captive spring washers (for pilot relay, M4×25)	398-204-250	4	-	1.8 ± 0.2
19	O-ring (AS568-014) (for pilot relay)	80020935-409	4	5	-
20	O-ring (S7) (for pilot relay)	80020935-323	1	5	-
21	A/M screw assembly	80388885-001	1	4	-
22	Filter	80377077-001	1	4	-
23	Holder	80377078-001	1	-	-
24	Cross recessed truss head screw (for A/M screw, M4×6)	310-240-060	1	-	1.5 ± 0.2
25	O-ring (AS568-007) (for A/M screw)	80020935-216	1	5	-
26	O-ring (AS568-010) (for A/M screw)	80020935-324	1	5	-
27	O-ring (AS568-012) (for A/M screw)	80020935-325	1	5	-

No.	Name	Part no.	Qty.	Recommended replacement period (year)*1	Recommended tightening torque N·m
28	Feedback lever assembly	80377049-001 (without option M6) 80377049-002 (with option M6)	1	-	-
29	Feedback lever	80377148-001 (with option M6) 80377148-002 (without option M6)	1	-	-
30	Arm spring	80377149-001 (with option M6) 80377149-002 (without option M6)	1	-	-
31	Hexagon socket bolt with captive spring washer (for feedback lever, M5×8)	80377127-001	2 (4)*2	-	2.9 ± 0.3
32	Extension lever	80377142-001 (40mm extension, without option M6) 80377142-101 (40mm extension, with option M6) 80377142-002 (80mm extension, without option M6) 80377142-102 (80mm extension, with option M6)	1	-	2.9 ± 0.3
33	Blind plug/pressure-resistant explosion-proof plug (G1/2)	80377115-001	1	5	-
34	Blind plug/plug (for general use, NPT1/2)	80277971-001	1	-	-
35	Blind plug/plug (for IECEx/ATEX, NPT1/2)	80372545-001	1	-	-
36	Blind plug/plug (for general use/ATEX, M20)	80377205-001	1	5	-
37	Blind plug/plug (for IECEx, M20)	80372699-001	1	5	-
38	Flameproof cable gland	80388728-002	1 (2)*3	10	-
39	Flameproof elbow (G1/2)	80357206-108	1 (2)*3	10	-
100	LCD cover	80384067-001	1	10	-
101	Pressure gauge elbow	80384049-001	2 (3)*4	-	-

\*1 The recommended replacement period assumes standard conditions (JIS C 1804, C 1805). The replacement period may be shorter depending on environmental conditions (such as temperature, humidity, vibration, and air quality) and usage conditions (such as operation frequency and ON/OFF operations).

\*2 If the extension lever is required.

\*3 When using two conduit connection ports.

\*4 When Pilot Relay Type is set to Double Acting.

## ⚠ Cautions



Do not replace or desorb the parts in the table below, because it causes the device damage. When you replace or desorb it, ask our service representative to replace the parts.

Ask our service representative to replace the parts in the table below. Expertise is required to replace these parts.

No.	Name	Part no.	Qty.	Recommended replacement period (year)*1	Recommended tightening torque N·m
41	Main cover assembly	80388816-001 (finish S, except for structure V) 80388816-002 (finish B, except for structure V) 80388816-011 (finish S, structure V) 80388816-012 (finish B, structure V)	1	5	-
42	O-ring (AS568-154) (for main cover)	80388828-154 (except for structure V) 80020935-164 (structure V)	1	5	-
44	Hexagon socket bolt (lock screw for main cover, M4×8)	314-204-080	1	-	0.9 ± 0.1
45	Guide plate	80388905-001	1	-	-
47	LCD assembly	80388931-001	1	5	-
50	Adapter assembly	80388836-001	1	-	0.9 ± 0.1
51	O-ring (AS568-021) (for adapter)	80020935-612	1	5	-
52	Hexagon socket bolt with captive spring washer (for adapter, M3×6)	80377046-001	3	-	0.9 ± 0.1
53	Adapter gasket	80388846-001	1	5	-
54	Filter screen	80377087-001	4	-	-
55	Cross recessed head screws with captive spring washer (for adapter, M4×12)	398-204-120	4	-	1.8 ± 0.2
56	Case packing	80388847-001	1	10	-
57	Magnet unit assembly (EPM)	80377010-001 (Forward) 80377010-002 (Reverse)	1	-	-
58	O-ring (AS568-007) (for EPM)	80020935-216	1	5	-
59	Hexagon socket bolt with captive spring washer (for EPM, M3×6)	80377046-001	2	-	0.9 ± 0.1
60	Sensor board	<Except for structure L,T> 80388935-001 <Structure L,T> 80384101-001	1	-	-
61	Sensor cable	80388944-001	1	-	-
62	O-ring (AS568A-013) (for pressure sensor)	80388829-013	4	10	-
63	Hexagon socket bolt with captive spring washer (for sensor cover, M3×8)	80377047-001	4	-	0.9 ± 0.1
64	Hexagon socket bolt with captive spring washer (for coil, M3×8)	80377047-001	2	-	0.9 ± 0.1

No.	Name	Part no.	Qty.	Recommended replacement period (year)*1	Recommended tightening torque N·m
65	Hexagon socket bolt with captive spring washer (M6×16)	80388845-001	4	-	4.4 ± 0.5
66	VTD assembly (with hexagon socket bolt M4×14)	80388909-001, 002	1	-	1.5 ± 0.2

\*1 The recommended replacement period assumes standard conditions (JIS C 1804, C 1805). The replacement period may be shorter depending on environmental conditions (such as temperature, humidity, vibration, and air quality) and usage conditions (such as operation frequency and ON/OFF operations).

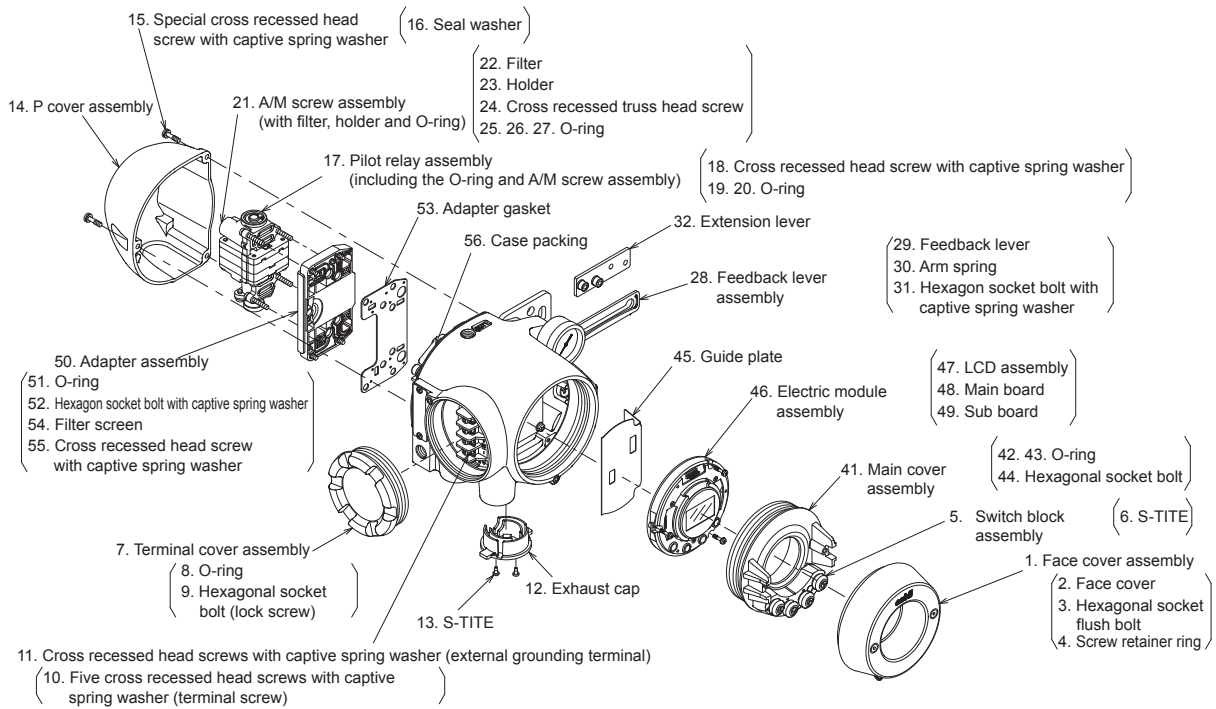

Figure 6-6 Resale Parts

### 6-9-1 Procedure to Change Switch Block

Step	Procedure
1	Loosen two screws with a hexagon socket screw keys and remove the face cover (Figure 6-7)
2	Loosen two screws and remove the face cover (Figure 6-8)
3	Tighten a new switch block with two screws. (Torque: $1.02 \pm 0.33N \cdot m$ )
4	Press four buttons and make sure whether the display changes or not.
5	Tighten the face cover with two screws. (Torque: $0.9 \pm 0.1N \cdot m$ )

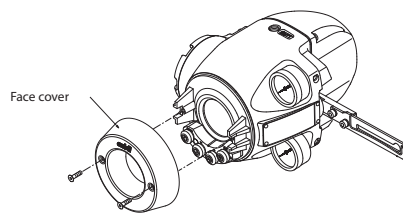

Figure 6-7 Removal of face cover

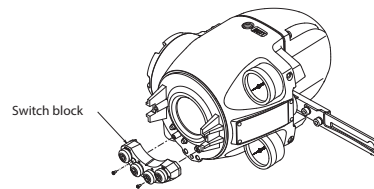

Figure 6-8 Removal of switch block

## 6-9-2 Procedure to Change Pilot Relay

Step	Procedure
1	Loosen three screws and remove the P cover. (Figure 6-9)
2	Loosen four screws and remove the pilot relay. (Figure 6-10)
3	Tighten a new pilot relay with four screws. (Torque: $1.8 \pm 0.2 \text{ N} \cdot \text{m}$ )
4	Tighten the P cover with three screws. (Torque: $1.5 \pm 0.2 \text{ N} \cdot \text{m}$ )

### Handling Precautions:

Please make sure that the O-ring does not fall off when assembling the pilot relay.

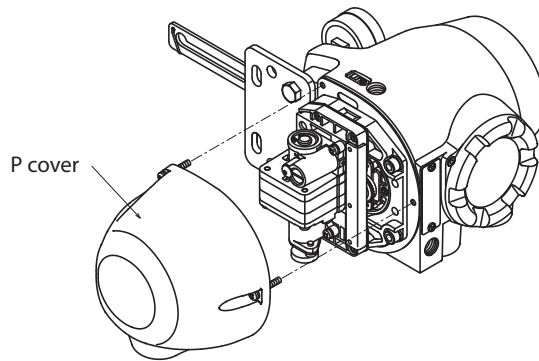

Figure 6-9 Removal of P cover

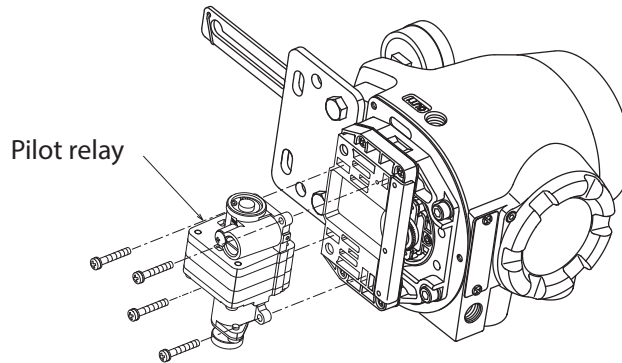

Figure 6-10 Removal of pilot relay



# Chapter 7 Notes on the Explosion-Proof 700 Series

This chapter describes the notes on the explosion-proof 700 Series.

When using the explosion-proof 700 Series, sufficiently understand the notes in this section and use it correctly.

## 7-1 TIIS Flameproof Model

### 1) Symbol information

#### **IIC T6**

Ambient gas with an ignition point of 85°C or higher  
Ambient gas with IIC explosion rating







Ambient temperature range: -20°C to +55°C

This pressure-resistant explosion-proof product can be installed in Place types 1 or 2 depending on the target gas. Installation in Place type 0 is not possible.

### 2) Applicable standards

Factory Electrical Facilities Explosion Protection Guidelines (Technical guidelines 2008 that conform to international standards)

### 3) Precautions for safe work

 <b>Warning</b>	
	Do not loosen the fixing screws on the cover and angle sensor while the power is applied and within one minute after the power supply is shut off. Doing so may cause an explosion, leading to a severe accident.
 <b>Cautions</b>	
	Be sure to mount the attached (specified) pressure-resistant packing cable adapter onto the signal wiring outlet in the device. Use the attached pressure-resistant elbow if it is necessary to change the orientation of the wiring. To guarantee the explosion-proof specifications, products other than the specified pressure-resistant packing cable adapter and pressure-resistant elbow cannot be used.
	Take extra care in handling the device so as not to corrode, deform, or otherwise damage the case or cover. Securely tighten the hexagon socket screws for screw locking on the cover and do not open the cover during use.
	When wiring in an environment similar to the low pressure power distribution work in a Class 1 danger zone, perform work following the “(New) Electrical Facilities Explosion-Proofing Guidelines (Gas Explosion-Proofing 1985)” issued by the Technology Institution of Industrial Safety.
	Apply the correct supply air pressure in accordance with the Chapter 2 Installation of the 700 Series. Incorrect pressure may cause abnormal actions of the control valve or damage to the pressure gauge.

## 7-2 IECEx Flameproof and Dust Ignition Protection

### IECEx Flameproof and Dust Ignition Protection

#### 1. Marking information

IECEx DEK 12.0025X

Ex d IIC T6 Gb  $-30^{\circ}\text{C} \leq T_{\text{amb}} \leq +75^{\circ}\text{C}$  IP66

Ex tb IIIC T85°C Db  $-30^{\circ}\text{C} \leq T_{\text{amb}} \leq +75^{\circ}\text{C}$  IP66

#### 2. Applicable standards

- IEC 60079-0:2011
- IEC 60079-1:2007
- IEC 60079-31:2008

#### 3. Special conditions for safe use Caution

- The gap between the shaft for magnetic pass and the pneumatic module body has 0.065mm max.
- The terminal cover has at least 7.5 engaged threads.
- The gap between the pneumatic module body and the housing has 0.13mm max.
- The electronic cover has at least 6.8 engaged threads.
- The gap between the housing and the feedback sensor has 0.11mm max.
- The gap between the flame arrestor and the pneumatic module body has 0.145mm max.
- The gap between the sensor housing and the outside sleeve has 0.07mm max.
- The gap between the rotary shaft and the inside sleeve has 0.07mm max.
- The screws used to assemble the pneumatic body to the Ex d housing shall be of class A2-70 or A4-70.
- For the use in the area where EPL Db apparatus is required, electrostatic discharge shall be avoided.

#### 4. Instruction for safe use Caution

- 4.1** Do not open when an explosive atmosphere is present.
- 4.2** Use supply wires suitable for 5°C above surrounding ambient.
- 4.3** When Model No. is given with AVP7xx-xyx-x ... ,  
if y=N, P, U, C, the thread type of the end of all entries is 1/2NPT, or  
if y=M, the thread type of the end of all entries is M20.
- 4.4** To maintain the degree of protection of at least IP66 in accordance with IEC60529, suitable cable glands, conduit sealing devices or blanking elements must be used and correctly installed.
- 4.5** Cables glands or conduit sealing devices used must be certified for the IECEx protection mentioned above in item 1.
- 4.6** This product is shipped with the IECEx certified blanking element only to avoid ingress of solid foreign objects and water during transportation, the certification of this product does not include the blanking element.  
When installed, check the conformity of the blanking element to the relevant standards.

- 4.6** Unused openings must be closed with a blanking element certified for the IECEx protection mentioned above in item 1.
- 4.7** If thread adapters are used these must be certified for the IECEx protection mentioned Above in item 1.  
Per entry not more than one thread adapter may be used.
- 4.8** This equipment shall be mounted in such a manner that it is not been heated by the process medium.
- 4.9** The cable connection of external grounding terminal shall be used with a cable lug.  
\*See the section 2-3 for the connection.
- 4.10** This product is shipped with the IECEx certified blanking element only to avoid ingress of solid foreign objects and water during transportation, the certification of this product does not include the blanking element.  
When installed, check the conformity of the blanking element to the relevant standards.

## 7-3 FM Explosionproof / Dust Ignition Protection

### Explosionproof

Class I, Division 1, Group B, C and D T6;

### Flameproof

Class I, Zone 1, AEx d IIC T6 Gb

### Dust ignition

Class II and III, Division 1, Group E, F, and G T6, Zone 21, AEx tb II C T85 °C Db

Ambient temperature : -30 to +75 °C

Indoor/Outdoor Enclosure IP66

#### WARNING

- Install the apparatus only in hazardous (classified) locations for which the apparatus has been approved.
- For division applications:
  - Factory sealed, conduit seal not required
  - Not including gasoline atmospheres
- Do not open the apparatus enclosure when an explosive atmosphere is present.

#### CAUTION

Use supply wires suitable for 5°C above surrounding ambient.

## 7-4 FM Intrinsically safe (ic) and Nonincendive

### Intrinsically safe(ic)

Class I, Zone 2, AEx ic IIC T4

Entity Parameters:

Positioner Circuit:  $U_i=30V$ ,  $I_i=100mA$ ,  $P_i=1W$ ,  $C_i=24nF$ ,  $L_i=0.22mH$

Transmitter Circuit (AVP701):  $U_i=30V$ ,  $I_i=100mA$ ,  $P_i=1W$ ,  $C_i=20nF$ ,  $L_i=0.22mH$

### Nonincendive

Class I, Division 2, Group A, B, C and D, T4

Nonincendive Field Wiring Parameters:

Positioner Circuit:  $V_{max}=30V$ ,  $I_{max}=100mA$ ,  $C_i=24nF$ ,  $L_i=0.22mH$

Transmitter Circuit (AVP701):  $V_{max}=30V$ ,  $I_{max}=100mA$ ,  $C_i=20nF$ ,  $L_i=0.22mH$

### Suitable

Class II and Class III, Division 2, Group E, F and G, T4

### Indoor/Outdoor Enclosure

NEMA Type 4X, IP66

Ambient Temperature:-24 to 75

### Instruction for safe use

- Models AVP701/ AVP702 shall be installed in accordance with control drawings 80396167 and 80396168.
- Installations in the US shall comply with the relevant requirements of the National Electrical CodeR (ANSI/NFPA-70 (NECR)).
- Tampering and replacement with non-factory components may adversely affect the safe use of the system.
- For guidance on installation in the US, see ANSI/ISA-RP12.06.01, Installation of Intrinsically Safe Systems for Hazardous (Classified) Locations.
- Electrical equipment connected to the Associated Apparatus shall not use or generate more than 250 Volts rms.
- The products discussed in this report were certified by FM Approvals under a Type3 Certification System as identified in ISO Guide 67.

79196E08

REV. 01

NI / NIFW

NON-HAZARDOUS LOCATION

HAZARDOUS (CLASSIFIED) LOCATION

NI, with NIFW Parameters.  
For CL I, II, III, DIV 2, GPs A, B, C, D, E, F, & G T4

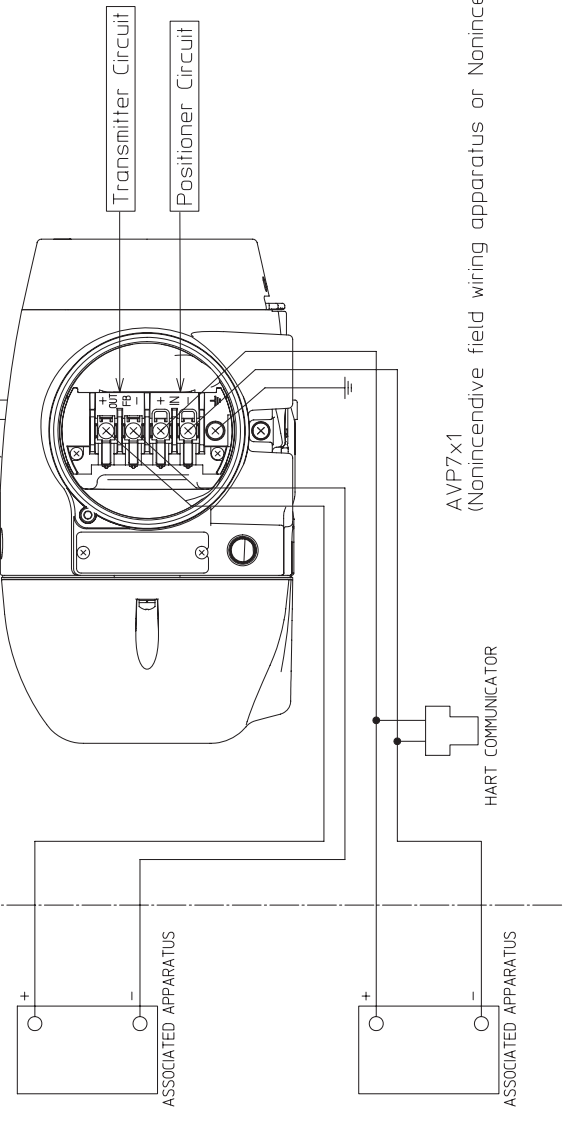

AVP7x1  
(Nonincendive field wiring apparatus or Nonincendive apparatus)

NOTES  
1) Approval agency controlled document, no changes without prior agency approval.

2) The Nonincendive field wiring apparatus can be connected only with associated apparatus separately approved by FM Approvals.

3) Nonincendive apparatus need not be accompanied by the associated apparatus.

4) NIFW parameters of the apparatus:  
Positioner Circuit  
 $V_{max} = 30V$ ,  $I_{max} = 100mA$ ,  $C_i = 24nF$ ,  $L_i = 0.22mH$

Transmitter Circuit  
 $V_{max} = 30V$ ,  $I_{max} = 100mA$ ,  $C_i = 20nF$ ,  $L_i = 0.22mH$

The parameters permitted for the associated apparatus are referred to its marking or specification.

5) Relevant wiring method of those for hazardous locations, specified by the National Electrical Code (ANSI/NFPA70), chapter 5 should be applied to the installation.

6) The FM Approvals approved HART Field Communicator can be connected as indicated by the above connection diagram.

7) Control equipment connected to the associated apparatus must not use or generate more than 250V r.m.s or Vdc.

8) Dust-tight conduit seal should be used when installed in class II and Class III environment.

9) To make the whole electrical loop NIFW, the following parameter matching formulas must be satisfied.

- $U_o < V_{max}$
- $I_o < I_{max}$
- $C_a > C_i + C_c + C_{HFC}$
- $L_a > L_i + L_c + L_{HFC}$

where  $U_o$ ,  $I_o$ :  
maximum output voltage and current taken from the associated apparatus.

$C_a$ ,  $L_a$ :  
maximum capacitance and inductance allowed to be connected to the associated apparatus.

$C_c$ ,  $L_c$ :  
specific capacitance and inductance given by the interconnecting cable.

$C_{HFC}$ ,  $L_{HFC}$ :  
NIFW parameters  $C_i$  and  $L_i$  of HART Field Communicator.

*** TITLE	AVP7x1
External Wiring	
FM NI / AEX IC	
*** REV.	02
*** SHI.	1/2

\*\*\* DWG. NO. 80396167

80396167

ONDMG #88

AEx ic

NON-HAZARDOUS LOCATION

HAZARDOUS (CLASSIFIED) LOCATION  
For CL I, ZONE 2, AEx ic IIC T4

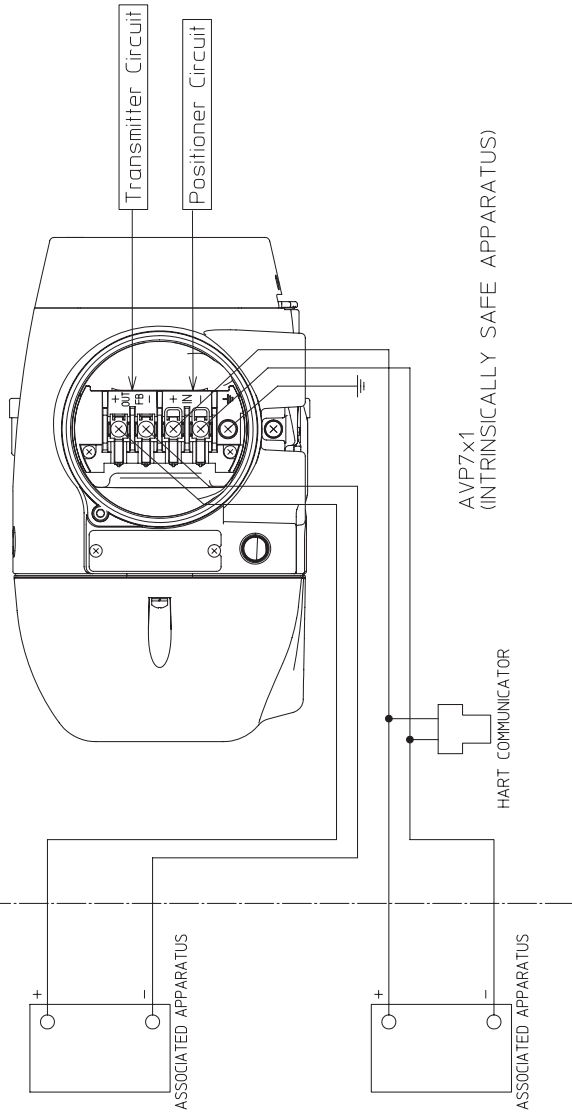

- NOTES
- 1) The intrinsically safe apparatus can be connected only with associated apparatus separately approved by FM Approvals.
  - 2) IS entity parameters of the apparatus :  
Positioner Circuit:  
 $U_i = 30V, I_i = 100mA, W = 1W, C_i = 24nF, L_i = 0.22mH$   
Transmitter Circuit:  
 $U_i = 30V, I_i = 100mA, W = 1W, C_i = 20nF, L_i = 0.22mH$   
The parameters permitted for the associated apparatus are referred to its marking or specification.
  - 3) Relevant wiring method of those for hazardous locations, specified by the National Electrical Code (ANSI/NFPA70), chapter 5 should be applied to the installation.
  - 4) The FM Approvals approved HART Field Communicator can be connected as indicated by the above connection diagram.
  - 5) Control equipment connected to the associated apparatus must not use or generate more than 250V r.m.s or Vdc.

- 6) To make the whole electrical loop intrinsically safe, the following entity parameter matching formulas must be satisfied.  
 $V_{oc} (or V_i) < U_i$   
 $I_{sc} (or I_i) < I_i$   
 $C_o > C_i + C_c + C_{#FC}$   
 $L_o > L_i + L_c + L_{#FC}$
- where  $V_{oc}$  ( or  $V_i$  ),  $I_{sc}$  ( or  $I_i$  ) :  
 maximum output voltage and current taken from the associated apparatus.  
 $C_o, L_o$  :  
 maximum capacitance and inductance allowed to be connected to the associated apparatus.  
 $C_c, L_c$  :  
 specific capacitance and inductance given by the interconnecting cable.  
 $G_{#FC}, L_{#FC}$  :  
 IS entity parameters  $C_i$  and  $L_i$  of HART Field Communicator.

*** TITLE	AVP7x1
External Wiring	FM NI / AEx ic
*** REV.	01
*** SHI.	2/2

*** DWG. NO.	80396167
8	
A3	



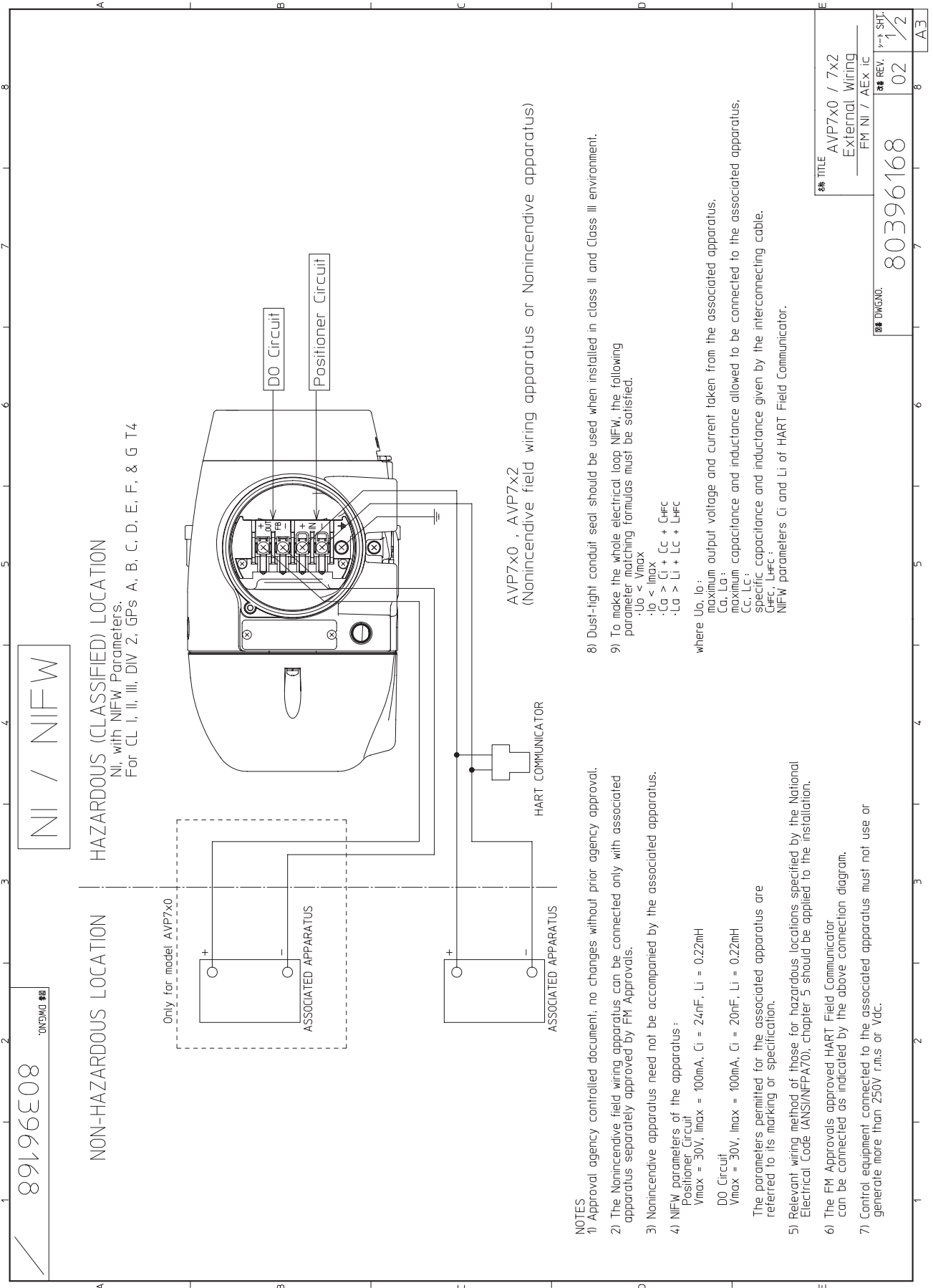

NI / NIFW

HAZARDOUS (CLASSIFIED) LOCATION  
 NI, with NIFW Parameters.  
 For CL I, II, III, DIV 2, GPs A, B, C, D, E, F, & G T4

AVP7x0, AVP7x2  
 (Nonincendive field wiring apparatus or Nonincendive apparatus)

- NOTES**
- 1) Approval agency controlled document, no changes without prior agency approval.
  - 2) The Nonincendive field wiring apparatus can be connected only with associated apparatus separately approved by FM Approvals.
  - 3) Nonincendive apparatus need not be accompanied by the associated apparatus.
  - 4) NIFW parameters of the apparatus:  
 Positioner Circuit:  
 $V_{max} = 30V$ ,  $I_{max} = 100mA$ ,  $C_i = 24nF$ ,  $L_i = 0.22mH$   
 DO Circuit:  
 $V_{max} = 30V$ ,  $I_{max} = 100mA$ ,  $C_i = 20nF$ ,  $L_i = 0.22mH$   
 The parameters permitted for the associated apparatus are referred to its marking or specification.
  - 5) Relevant wiring method of those for hazardous locations specified by the National Electrical Code (ANSI/NFPA70), chapter 5 should be applied to the installation.
  - 6) The FM Approvals approved HART Field Communicator can be connected as indicated by the above connection diagram.
  - 7) Control equipment connected to the associated apparatus must not use or generate more than 250V r.m.s or Vdc.
- 8) Dust-tight conduit seal should be used when installed in class II and Class III environment.
- 9) To make the whole electrical loop NIFW, the following parameter matching formulas must be satisfied.
- $U_o < V_{max}$
  - $I_o < I_{max}$
  - $C_a > C_i + C_c + C_{#C}$
  - $L_a > L_i + L_c + L_{#C}$
- where  $U_o$ ,  $I_o$ :  
 - maximum output voltage and current taken from the associated apparatus.  
 $C_a$ ,  $L_a$ :  
 - maximum capacitance and inductance allowed to be connected to the associated apparatus.  
 $C_c$ ,  $L_c$ :  
 - specific capacitance and inductance given by the interconnecting cable.  
 $C_{#C}$ ,  $L_{#C}$ :  
 - NIFW parameters  $C_i$  and  $L_i$  of HART Field Communicator.

REV. NO.	02	REV. DATE	1/2
	01		1/2
DWG. NO.		80396168	
TITLE		AVP7x0 / 7x2 External Wiring FM NI / AEX IC	

89196E08

REV. 01

AEx ic

NON-HAZARDOUS LOCATION

HAZARDOUS (CLASSIFIED) LOCATION  
For CL I, ZONE 2, AEx ic IIC T4

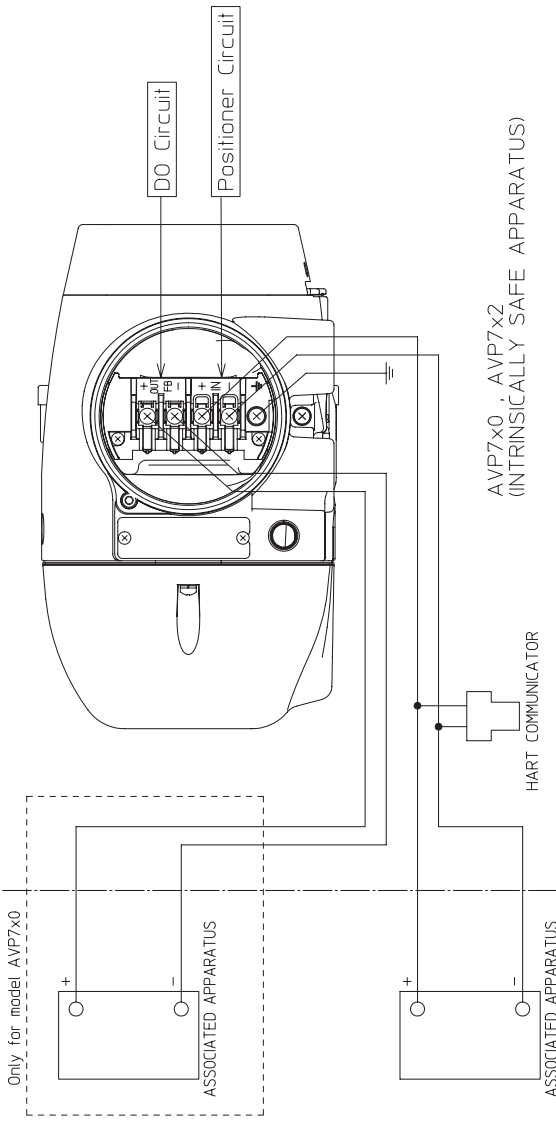

AVP7x0 , AVP7x2  
(INTRINSICALLY SAFE APPARATUS)

NOTES

- 1) Approval agency controlled document; no changes without prior agency approval.
- 2) The intrinsically safe apparatus can be connected only with associated apparatus separately approved by FM Approvals.
- 3) IS entity parameters of the apparatus :  
Positioner Circuit:  
 $U_i = 30V, I_i = 100mA, P_i = 1W, C_i = 24nF, L_i = 0.22mH$   
DO Circuit:  
 $U_i = 30V, I_i = 100mA, P_i = 1W, C_i = 20nF, L_i = 0.22mH$

The parameters permitted for the associated apparatus are referred to its marking or specification.

- 4) Relevant wiring method of those for hazardous locations specified by the National Electrical Code (ANSI/NFPA70), chapter 5 should be applied to the installation.
- 5) The FM Approvals approved HART Field Communicator can be connected as indicated by the above connection diagram.
- 6) Control equipment connected to the associated apparatus must not use or generate more than 250V r.m.s or Vdc.

- 7) To make the whole electrical loop intrinsically safe, the following entity parameter matching formulas must be satisfied.

- $V_{oc} ( \text{ or } V_i ) < U_i$
- $I_{sc} ( \text{ or } I_i ) < I_i$
- $C_o > C_i + C_c + C_{HFC}$
- $L_o > L_i + L_c + L_{HFC}$

where  $V_{oc}$  ( or  $V_i$  ),  $I_{sc}$  ( or  $I_i$  );  
 $C_o, L_o$ : maximum output voltage and current taken from the associated apparatus,  
 $C_c, L_c$ : maximum capacitance and inductance allowed to be connected to the associated apparatus,  
 $C_{HFC}, L_{HFC}$ : specific capacitance and inductance given by the interconnecting cable.  
 IS entity parameters  $C_i$  and  $L_i$  of HART Field Communicator.

#* TITLE AVP7x0 / 7x2 External Wiring FM NI / AEx ic	#* REV. 02	#* SHT. 2/2

## 7-5 FMC Explosionproof / Dust Ignition Protection

### Explosionproof

Class I, Division 1, Group C and D T6;

### Flameproof

Class I, Zone 1, Ex d IIB T6 Gb

### Dust ignition

Class II and III, Division 1, Group E, F, and G T6;

Ambient temperature : -30 to +75 °C

Indoor/Outdoor Enclosure IP66

#### WARNING

- Install the apparatus only in hazardous (classified) locations for which the apparatus has been approved.
- For division applications:
  - Factory sealed, conduit seal not required
  - Not including gasoline atmospheres
- For zone applications
  - Seal all conduits within 450mm (18 INCHES)
- Do not open the apparatus enclosure when an explosive atmosphere is present.

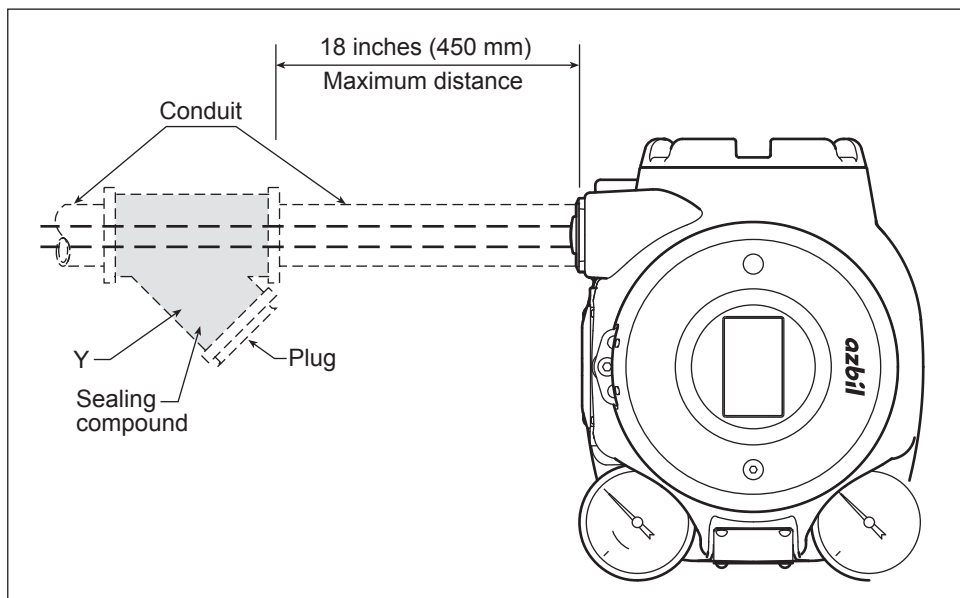

#### CAUTION

Use supply wires suitable for 5°C above surrounding ambient.

## 7-6 CCC Flameproof / Dust Ignition Protection

### CCC 隔爆

#### 1. 防爆标志

Ex db IIC T6 Gb

Ex tb IIIC T85°C Db

#### 2. 国家防爆标准

GB/T 3836.1-2021 爆炸性环境 第1 部分：设备 通用要求

GB/T 3836.2-2021 爆炸性环境 第2 部分：由隔爆外壳“d”保护的设备

GB/T 3836.31-2021 爆炸性环境 第31 部分：由防粉尘点燃外壳“t”保护的设备

#### 3. 产品安全使用特殊条件

3-1. 涉及隔爆接合面的维修须联系产品制造商。

3-2. 隔爆结合面用特殊紧固件性能等级为A2-70/A4-70。

3-3. 产品在爆炸性粉尘环境使用时，应采取措施避免传播型刷型放电产生引燃危险。  
仅允许使用湿布擦拭。

3-4. 使用环境温度：-30°C~+75°C。

#### 4. 产品使用注意事项

4-1. 产品设有外接地端子，用户在安装使用时应可靠接地。

4-2. 产品电缆引入口须配用经国家指定的检验机构认可的、符合国家标准GB/T 3836.1-2021和GB/T 3836.2-2021 规定的、螺纹规格为M20×1.5 或1/2-14NPT、具有防爆等级为Ex db IIC 的电缆引入装置或封堵件，方可用于爆炸性危险场所。该电缆引入装置或封堵件的使用必须符合使用说明书的要求。冗余电缆引入口应有效封堵。电缆引入装置或封堵件安装后，须确保设备整体外壳防护等级不低于IP66。

4-3. 现场使用和维护时，必须遵循“存在爆炸性环境时严禁打开”的原则。

4-4. 用户不得自行更换该产品的零部件，应会同产品制造商共同解决运行中出现的故障，以杜绝损坏现象的发生。

4-5. 用户应当保持产品外壳表面清洁，以防粉尘堆积，但严禁用压缩空气吹扫。

4-6. 产品的安装、使用和维护应同时遵守产品说明书及下列相关标准、规范的要求：

GB/T 3836.13-2021 爆炸性环境 第13 部分：设备的修理、检修、修复和改造

GB/T 3836.15-2017 爆炸性环境 第15 部分：电气装置的设计、选型和安装

GB/T 3836.16-2017 爆炸性环境 第16 部分：电气装置的检查与维护

GB 15577-2018 粉尘防爆安全规程

GB 50257-2014 电气装置安装工程爆炸和火灾危险环境 电气装置施工及验收规范

## CCC 型号

AVP7xy - ①②③ - ④⑤⑥⑦

where:

x=0(Valve positioner)

x=1(Emergency valve shutdown function with Foundation Fieldbus communication)

x=3(valve travel transmitter only)

x=7(Positioner with emergency valve shutdown function @4.48mA)

x=8(Positioner with emergency valve shutdown function @0.5mA)

x=9(Emergency valve shutdown function only)

y=0(Positioner & contact output for alarm)

y=1(Positioner& Valve travel transmitter)

y=2(no output)

x=3(Foundation Fieldbus communication)

y=4(Positioner & Foundation Fieldbus communication)

AVP7xy 所有组合搭配： AVP700/701/702/703/704/770/771/772/780/781/782/790/791/792/  
713/731

					Code
① Structure	CCC Flameproof / Dust ignition protection (Electrical connection G1/2 is not available)				N
	CCC Intrinsically Safe				R
② Connection	Electrical connection	Air piping connection	Mounting thread	Pressure gauge thread	
	M20x1.5	1/4NPT	M8	Rc1/8	M
	1/2NPT	1/4NPT	M8	Rc1/8	N
	1/2NPT	1/4NPT	M8	1/8NPT	P
	1/2NPT	1/4NPT	5/16-18UNC	Rc1/8	U
	1/2NPT	1/4NPT	5/16-18UNC	1/8NPT	C
	G1/2	Rc1/4	M8	Rc1/8	G
③ Finish	Standard				S
	Corrosion Proof				B
	Silver Finish				D
④⑤ Display	Display with push button				DX
⑥ Diagnostic	Advanced diagnosis				A
⑦ Overvoltage Protection	None				X
	With overvoltage protection				V

## 7-7 KCs Flameproof

### 1. Marking information

Ex d IIC T6  $-30^{\circ}\text{C} < T_{\text{amb}} < +75^{\circ}\text{C}$

### 2. Special conditions for safe use Caution

- The gap between the shaft for magnetic pass and the pneumatic module body has 0.065 mm max.
- The terminal cover has at least 7.5 engaged threads.
- The gap between the pneumatic module body and the housing has 0.13 mm max.
- The electronic cover has at least 6.8 engaged threads.
- The gap between the housing and the feedback sensor has 0.11 mm max.
- The gap between the flame arrestor and the pneumatic module body has 0.145 mm max.
- The gap between the sensor housing and the outside sleeve has 0.07 mm max.
- The gap between the rotary shaft and the inside sleeve has 0.07 mm max.
- The screws used to assemble the pneumatic body to the Ex d housing shall be of class A2-70 or A4-70.

### 3. Instruction for safe use Caution

- 3.1** Do not open when an explosive atmosphere is present.
- 3.2** Use supply wires suitable for 5°C above surrounding ambient.
- 3.3** When Model No. is given with AVP7xx-xyx-x ... ,  
if y=N, P, U, C, the thread type of the end of all entries is 1/2NPT, or  
if y=M, the thread type of the end of all entries is M20.
- 3.4** Cables glands or conduit sealing devices used must be certified for the protection mentioned above in item 1.
- 3.5** Unused openings must be closed with a blanking element certified for the protection mentioned above in item 1.
- 3.6** If thread adapters are used these must be certified for the protection mentioned Above in item 1.  
Per entry not more than one thread adapter may be used.
- 3.7** This equipment shall be mounted in such a manner that it is not been heated by the process medium.
- 3.8** The cable connection of external grounding terminal shall be used with a cable lug.  
\*See the section 2-3-3 for the connection.

## 7-8 INMETRO Flameproof / Dust Ignition Protection

### Equipamento à prova de explosão do INMETRO

#### Segurança

##### Sobre este manual

Este manual contém informações e advertências que devem ser observadas para manter posicionador de válvula smart o AVP7XX que opera seguramente. Instalação correta, operação correta e manutenção regular são essenciais para assegurar segurança enquanto usando este dispositivo.

Para o uso correto e seguro deste dispositivo é essencial que ambos que operam e pessoal de serviço segue procedimentos de segurança geralmente aceitos além das precauções de segurança especificadas neste manual.

Os símbolos seguintes são usados neste manual para alertar a possíveis perigos:

##### Advertência

Denota um potencialmente situação perigosa que, se não evitou, poderia resultar em morte ou dano sério.

##### Precaução

Denota uma situação potencialmente situação perigosa que, se não evitar, poderá resultar em um dano secundário ao operador ou poderá danificar o dispositivo.

~ Informação de nota que pode ser útil ao usuário.

##### Precauções de segurança

ADVERTINDO

- PERIGO DE CHOQUE ELÉTRICO! Desligue antes de executar qualquer instalação elétrica.
- NUNCA abra a tampa do invólucro do terminal enquanto o AVP7XX está energizado em um ambiente de atmosfera explosiva.
- Não toque o AVP7XX desnecessariamente enquanto estiver em operação. A superfície pode estar muito quente ou muito fria, enquanto dependendo do ambiente operacional.

##### PRECAUÇÃO

Não pisar, apoiar-se ou subir no AVP7XX. Você pode danificar o aparelho.

## 1. Marcação conforme a Portaria 179 do INMETRO:

Azbil Corporation  
Tipo:AVP 7XX  
Ex db IIC T6 Gb  
Ex tb IIIC T85 °C Db  
 $-30\text{ °C} \leq T_a \leq +75\text{ °C}$   
Número de série: ...  
NCC 14.3175 X

ATENÇÃO – NÃO ABRA QUANDO UMA ATMOSFERA EXPLOSIVA PUDER  
ESTAR  
PRESENTE

## 2. Normas conforme a Portaria 179 do INMETRO:

ABNT NBR IEC 60079-0:2013  
ABNT NBR IEC 60079-1:2009  
ABNT NBR IEC 60079-31:2011

## 3. Condições especiais para uso seguro:

- As dimensões das juntas à prova de explosão estão detalhadas nos documentos do fabricante.
- Os parafusos usados para montar o corpo pneumático do invólucro 'Ex d' devem ser de classes A2-70 ou A4-70.
- Quando usado em área onde são exigidos equipamentos com nível de proteção EPL Db, deve ser evitada descarga eletrostática.

## 4. Instruções para o uso seguro

Este produto é expedido com o elemento de vedação certificado por IECEx apenas para evitar a entrada de objetos estranhos sólidos e água durante o transporte.

A certificação deste produto não inclui o elemento de vedação.

Ao instalar, verifique a conformidade do elemento de vedação com os padrões pertinentes.



## 7-9 EAC Flameproof

Взрывозащищенное исполнение в соответствии с техническим регламентом ТР ТС 012/2011 «О безопасности оборудования для работы во взрывоопасных средах»

### 1. Маркировка

EAЭС RU C-JP.EX01.B.00075/19

1Ex d IIC T6 Gb X -30 °C ≤ Ta ≤ +75 °C IP66

Ex tb IIIC T85°C Db X -30 °C ≤ Ta ≤ +75 °C IP66

### 2. Применяемые стандарты

- ГОСТ 31610.0-2014 (IEC 60079-0:2011)
- ГОСТ IEC 60079-1-2011
- ГОСТ IEC 60079-31-2013

### 3. Специальные условия применения

- Зазор между валом магнитного блока и корпусом пневматического модуля должен быть не больше 0,065 мм.
- Крышка клеммной коробки должна быть закручена по резьбе как минимум на 7,5 оборотов.
- Зазор между корпусом пневматического модуля и оболочкой изделия должен быть не больше 0,13 мм.
- Крышка электроники должна быть закручена по резьбе как минимум на 6,8 оборотов.
- Зазор между корпусом изделия и датчиком обратной связи должен быть не больше 0,11 мм.
- Зазор между пламегасителем и корпусом пневматического модуля должен быть не больше 0,145 мм.
- Зазор между корпусом датчика и наружным рукавом должен быть не больше 0,07 мм.
- Зазор между вращающимся валом и внутренним рукавом должен быть не больше 0,07 мм.
- Для крепления пневматического модуля к оболочке Ex d следует использовать винты класса A2-70 или A4-70.
- Корпуса позиционеров способны накапливать электростатический заряд, поэтому они должны устанавливаться в местах, где риск электростатического разряда сведен к минимуму.
- Ремонт взрывонепроницаемых соединений позиционеров допускается, если он произведен изготовителем или его уполномоченным представителем.

#### **4. Инструкции для безопасной эксплуатации**

- 4.1** Не открывайте корпус при наличии взрывоопасной атмосферы.
- 4.2** Используйте подходящие кабели и кабельные вводы с температурным диапазоном на 5°C выше температуры окружающей среды.
- 4.3** Чтобы обеспечить степень защиты не ниже IP66 в соответствии со стандартом IEC 60529, необходимо использовать и правильно устанавливать подходящие кабельные вводы, уплотнения кабелепроводов и заглушки.
- 4.4** Используемые кабельные вводы и уплотнения кабелепроводов должны иметь соответствующий сертификат взрывозащиты.
- 4.5** Неиспользуемые отверстия должны быть закрыты заглушками, имеющими соответствующий сертификат взрывозащиты.
- 4.6** Если используются резьбовые переходники, они должны иметь сертификат соответствующий сертификат взрывозащиты. Можно использовать не более одного переходника на каждый ввод.
- 4.7** Данное оборудование следует устанавливать так, чтобы оно не нагревалось за счет технологической среды.
- 4.8** Соединительный кабель внешнего заземления должен быть оснащен кабельным наконечником.  
\* Описание подключения см. в разделе 2-3.
- 4.9** Данное изделие комплектуется заглушкой с сертификатом IECEx лишь для предотвращения попадания внутрь посторонних предметов и воды во время транспортировки, и эта заглушка не включается в сертификацию изделия. Во время установки убедитесь, что заглушка соответствует надлежащим стандартам.

## 7-10 ATEX Intrinsic Safety and Dust Ignition Protection

### 1. Marking information



II 1G Ex ia IIC T4 Ga  $-40^{\circ}\text{C} \leq \text{Ta} \leq +60^{\circ}\text{C}$   
II 1D Ex ia IIIC T135°C Da  $-40^{\circ}\text{C} \leq \text{Ta} \leq +60^{\circ}\text{C}$  IP66

+/-IN  $U_i = 30\text{V}$ ,  $I_i = 93\text{mA}$ ,  $P_i = 0.9\text{W}$ ,  $C_i = 4\text{nF}$ ,  $L_i = 220\mu\text{H}$

+/-OUT(AVP7x0/AVP7x1)  $U_i = 30\text{V}$ ,  $I_i = 93\text{mA}$ ,  $P_i = 0.9\text{W}$ ,  $C_i = 22\text{nF}$ ,  $L_i = 220\mu\text{H}$

### 2. Applicable standards

- EN IEC 60079-0: 2018
- EN 60079-11: 2012

### 3. Special conditions for safe use Caution

- 3.1** For Group III, the enclosure must be mounted in a location where the risk of electrostatic discharge is minimised.
- 3.2** The enclosure of the product is made of aluminium, if it is mounted in an area where the use of EPL Ga apparatus is required, it must be installed such that, even in the event of rare incidents, ignition sources due to impact or friction sparks are excluded.
- 3.3** The equipment is not capable of passing a 500V dielectric strength test between the power and signal connections and the housing. This shall be taken into account during installation.

### 4. Instruction for safe use Caution

- 4.1** To maintain the degree of protection of IP66 in accordance with IEC 60529, suitable cable glands, conduit sealing devices or blanking elements must be used and correctly installed.
- 4.2** The equipment is to be connected with power supplies through a safety barrier suitable for the terminal parameters of the equipment.

# 7-11 IECEx Intrinsic Safety and Dust Ignition Protection

## 1. Marking information

IECEx BAS 16.0069X

Ex ia IIC T4 Ga  $-40^{\circ}\text{C} \leq T_a \leq +60^{\circ}\text{C}$

Ex ia IIIC T135°C Da  $-40^{\circ}\text{C} \leq T_a \leq +60^{\circ}\text{C}$  IP66

+/-IN  $U_i = 30\text{V}$ ,  $I_i = 93\text{mA}$ ,  $P_i = 0.9\text{W}$ ,  $C_i = 4\text{nF}$ ,  $L_i = 220\mu\text{H}$

+/-OUT(AVP7x0/AVP7x1)  $U_i = 30\text{V}$ ,  $I_i = 93\text{mA}$ ,  $P_i = 0.9\text{W}$ ,  $C_i = 22\text{nF}$ ,  $L_i = 220\mu\text{H}$

## 2. Applicable standards

- IEC 60079-0 : 2017

- IEC 60079-11 : 2011

## 3. Special conditions for safe use Caution

- 3.1** For Group III, the enclosure must be mounted in a location where the risk of electrostatic discharge is minimised.
- 3.2** The enclosure of the product is made of aluminium, if it is mounted in an area where the use of EPL Ga apparatus is required, it must be installed such that, even in the event of rare incidents, ignition sources due to impact or friction sparks are excluded.
- 3.3** The equipment is not capable of passing a 500V dielectric strength test between the power and signal connections and the housing. This shall be taken into account during installation.

## 4. Instruction for safe use Caution

- 4.1** To maintain the degree of protection of IP66 in accordance with IEC 60529, suitable cable glands, conduit sealing devices or blanking elements must be used and correctly installed.

## 7-12 CCC Intrinsic Safety and Dust Ignition Protection

### CCC 本安防爆

#### 1. 防爆标志

Ex ia IIC T4 Ga

Ex ia IIIC T<sub>200</sub>135°C Da

#### 2. 国家防爆标准

GB/T 3836.1-2021 爆炸性环境 第1部分：设备 通用要求

GB/T 3836.4-2021 爆炸性环境 第4部分：由本质安全型 “i” 保护的的设备

#### 3. 产品安全使用特殊条件

3-1. 当产品安装于要求EPL Ga级的场所时，用户须采取有效措施防止产品外壳由于冲击或摩擦引起的点燃危险。

3-2. 产品在爆炸性粉尘环境使用时，应采取措施避免传播型刷型放电产生引燃危险。仅允许使用湿布擦拭。

3-3. 关联设备应优先选用隔离式安全栅；如选用齐纳式安全栅，应符合GB/T 3836.15-2017标准关于本安电路接地的要求。

3-4. 使用环境温度：-40°C~+60°C。

#### 4. 产品使用注意事项

4-1. 产品使用环境温度范围：-40°C~+60°C。

4-2. 产品必须与经防爆检验认可的关联设备配套共同组成本安防爆系统方可使用于现场存在爆炸性气体混合物的危险场所。其系统接线必须同时遵守该产品和所配关联设备的使用说明书要求，接线端子不得接错。产品本安电气参数见下表：

##### 4.2.1 AVP7a 0 AVP7a 1 AVP7a 2

输入信号端子：

最高输入电压 U <sub>i</sub> (V)	最大输入电流 I <sub>i</sub> (mA)	最大输入功率 P <sub>i</sub> (W)	最大内部等效参数	
			C <sub>i</sub> (nF)	L <sub>i</sub> (μH)
30	93	0.9	4	220

输出信号端子：

最高输出电压 U <sub>o</sub> (V)	最大输入电流 I <sub>o</sub> (mA)	最大输入功率 P <sub>o</sub> (W)	最大内部等效参数	
			C <sub>o</sub> (nF)	L <sub>o</sub> (μH)
30	93	0.9	22	220

##### 4-2.2 AVP703型用户端子

最高输入电压 U <sub>i</sub> (V)	最大输入电流 I <sub>i</sub> (mA)	最大输入功率 P <sub>i</sub> (W)	最大内部等效参数	
			C <sub>i</sub> (nF)	L <sub>i</sub> (μH)
17.5	380	5.32	2	近似为0

- 4-3. 用户不得自行更换该产品的零部件，应会同产品制造商共同解决运行中出现的故障，以杜绝损坏现象的发生。
- 4-4. 用户应当保持产品外壳表面清洁，以防粉尘堆积，但严禁用压缩空气吹扫。
- 4-5. 产品的安装、使用和维护应同时遵守产品说明书及下列相关标准、规范的要求：  
GB/T 3836.13-2021 爆炸性环境 第13部分：设备的修理、检修、修复和改造  
GB/T 3836.15-2017 爆炸性气体环境用电气设备 第15部分：危险场所电气安装  
(煤矿除外)  
GB/T 3836.16-2017 爆炸性气体环境用电气设备 第16部分：电气装置的检查和维护  
(煤矿除外)  
GB/T 3836.18-2017 爆炸性环境 第18部分：本质安全系统  
GB 15577-2018 粉尘防爆安全规程  
GB 50257-2014 电气装置安装工程爆炸和火灾危险环境 电气装置施工及验收规范

## CCC 型号

AVP7xy - ①②③ - ④⑤⑥⑦

where:

x=0(Valve positioner)

x=1(Emergency valve shutdown function with Foundation Fieldbus communication)

x=3(valve travel transmitter only)

x=7(Positioner with emergency valve shutdown function @4.48mA)

x=8(Positioner with emergency valve shutdown function @0.5mA)

x=9(Emergency valve shutdown function only)

y=0(Positioner & contact output for alarm)

y=1(Positioner& Valve travel transmitter)

y=2(no output)

x=3(Foundation Fieldbus communication)

y=4(Positioner & Foundation Fieldbus communication)

AVP7xy 所有组合搭配： AVP700/701/702/703/704/770/771/772/780/781/782/790/791/792/  
713/731

					Code
① Structure	CCC Flameproof / Dust ignition protection (Electrical connection G1/2 is not available)				N
	CCC Intrinsically Safe				R
② Connection	Electrical connection	Air piping connection	Mounting thread	Pressure gauge thread	
	M20x1.5	1/4NPT	M8	Rc1/8	M
	1/2NPT	1/4NPT	M8	Rc1/8	N
	1/2NPT	1/4NPT	M8	1/8NPT	P
	1/2NPT	1/4NPT	5/16-18UNC	Rc1/8	U
	1/2NPT	1/4NPT	5/16-18UNC	1/8NPT	C
	G1/2	Rc1/4	M8	Rc1/8	G
③ Finish	Standard				S
	Corrosion Proof				B
	Silver Finish				D
④⑤ Display	Display with push button				DX
⑥ Diagnostic	Advanced diagnosis				A
⑦ Overvoltage Protection	None				X
	With overvoltage protection				V

## 7-13 CNS Flameproof

### CNS 耐壓防爆外殼認證

#### 1. 防爆等級內容

型式檢定合格字號 工電(2016)第 00229X 號

防爆規格標示

Ex d IIC T6 Gb  $-30^{\circ}\text{C} \leq T_{\text{amb}} \leq +75^{\circ}\text{C}$

#### 2. 依據標準

IEC 60079-0 : 2011

IEC 60079-1 : 2007

#### 3. 電氣規格

型式	輸入	輸出	最大消耗功率
AVP701	20mA dc	20mA、45V dc	1.16W
AVP702	20mA dc	N/A	0.26W
AVP703	Fieldbus	20mA、32V dc	0.64W
AVP770	20mA dc	100mA、30V dc	0.76W
AVP771	20mA dc	20mA、45V dc	1.16W
AVP772	20mA dc	N/A	0.26W
AVP780	20mA dc	100mA、30V dc	0.76W
AVP781	20mA dc	20mA、45V dc	1.16W
AVP782	20mA dc	N/A	0.26W
AVP790	35mA dc	100mA、30V dc	0.955W
AVP791	35mA dc	20mA、45V dc	1.355W
AVP792	35mA dc	N/A	0.455W

#### 4. 特殊條件

檢定範圍未包含電纜入口保護裝置，應正確使用合格電纜接頭或盲塞以維持設備保護型式之完整性；

有關耐壓防爆接合面尺寸詳見製造商文件；

用於將氣壓本體組裝至耐壓防爆外殼的螺栓，性能等級應為 A2-70 或 A4-70。



## 7-14 CNS Intrinsic Safety and Dust Ignition Protection

### CNS 本質安全認證

#### 1. 防爆等級內容

型式檢定合格字號 (ITRI)2019第07-00133X號

防爆規格標示

Ex ia IIC T4 Ga  $-40^{\circ}\text{C} \leq T_{\text{amb}} \leq +60^{\circ}\text{C}$

Ex ia IIIC T135°C Da  $-40^{\circ}\text{C} \leq T_{\text{amb}} \leq +60^{\circ}\text{C}$

#### 2. 依據標準

IEC 60079-0 : 2017

IEC 60079-11 : 2011

#### 3. 電氣規格

AVP7x0、AVP7x1、AVP7x2型

輸入信號端 :  $U_i = 30\text{V}$ 、 $I_i = 93\text{mA}$ 、 $P_i = 0.9\text{W}$ 、 $C_i = 4\text{nF}$ 、 $L_i = 220\mu\text{H}$ 。

輸出信號端 :  $U_i = 30\text{V}$ 、 $I_i = 93\text{mA}$ 、 $P_i = 0.9\text{W}$ 、 $C_i = 22\text{nF}$ 、 $L_i = 220\mu\text{H}$ 。

AVP703型

使用者端 :  $U_i = 17.5\text{V}$ 、 $I_i = 380\text{mA}$ 、 $P_i = 5.32\text{W}$ 、 $C_i = 2\text{nF}$ 、 $L_i =$  可忽略。

#### 4. 特殊條件

檢定範圍未包含電纜入口保護裝置，應正確使用合格電纜接頭或盲塞以維持設備保護型式之完整性；

本設備安裝於需粉塵防爆的區域時，應讓靜電風險降至最低。

本設備鋁製外殼安裝於需 EPL Ga 區域使用時，應避免外殼碰撞或摩擦；

本設備無法通過電源端，信號端與外殼間的介電強度試驗，此情況於安裝時需納入考量。

## 7-15 NEPSI Intrinsic Safety and Dust Ignition Protection

### NEPSI 本质安全认证

#### 1. 标志资讯

GYJ23.1038X

Ex ia IIC T4 Ga  $-40^{\circ}\text{C} \leq T_{\text{amb}} \leq +60^{\circ}\text{C}$ 、Ex ia IIIC T<sub>200</sub> 135°C Da

#### 2. 适用的标准

-GB/T 3836.1-2021

-GB/T 3836.4-2021

#### 3. 产品安全使用特殊条件

防爆合格证号后缀“X”表明产品具有安全使用特殊条件，具体内容如下：

1. 当产品安装于要求EPL Ga 级的场所时，用户须采取有效措施防止产品外壳由于冲击或摩擦引起的点燃危险。
2. 关联设备应优先选用隔离式安全栅；如选用齐纳式安全栅，应符合GB/T 3836.15-2017 标准关于本安电路接地的要求。
3. 在可燃性粉尘环境中应用时，应避免将产品安装于存在静电释放危险的场所。
4. 产品使用环境温度范围： $-40^{\circ}\text{C} \sim +60^{\circ}\text{C}$ 。

#### 4. 产品使用注意事项

1. 产品必须与经防爆检验认可的关联设备配套共同组成本安防爆系统方可使用于现场存在爆炸性混合物的危险场所。其系统接线必须同时遵守该产品和所配关联设备的使用说明书要求，接线端子不得接错。

产品本安电气参数见下表：

##### 1.1 AVP7a 0、AVP7a 1、AVP7a 2

输入信号端子：

最高输入电压 $U_i$ (V)	最大输入电流 $I_i$ (mA)	最大输入功率 $P_i$ (W)	最大内部等效参数	
			$C_i$ (nF)	$L_i$ ( $\mu\text{H}$ )
30	93	0.9	4	220

输出信号端子：

最高输出电压 $U_o$ (V)	最大输入电流 $I_o$ (mA)	最大输入功率 $P_o$ (W)	最大内部等效参数	
			$C_o$ (nF)	$L_o$ ( $\mu\text{H}$ )
30	93	0.9	22	220

##### 1.2 AVP703 型用户端子

最高输入电压 $U_i$ (V)	最大输入电流 $I_i$ (mA)	最大输入功率 $P_i$ (W)	最大内部等效参数	
			$C_i$ (nF)	$L_i$ ( $\mu\text{H}$ )
17.5	380	5.32	2	近似为 0

2. 用户不得自行更换该产品的零部件，应会同产品制造商共同解决运行中出现的故障，以杜绝损坏现象的发生。
3. 用户应当保持产品外壳表面清洁，以防粉尘堆积，但严禁用压缩空气吹扫。
4. 产品的安装、使用和维护应同时遵守产品说明书及下列相关标准、规范的要求：
  - GB/T 3836.13-2021 爆炸性环境 第13 部分：设备的修理、检修、修复和改造
  - GB/T 3836.15-2017 爆炸性环境 第15 部分：电气装置的设计、选型和安装
  - GB/T 3836.16-2017 爆炸性环境 第16 部分：电气装置的检查与维护
  - GB/T 3836.18-2017 爆炸性环境 第18 部分：本质安全电气系统
  - GB 50257-2014 电气装置安装工程爆炸和火灾危险环境 电气装置施工及验收规范
  - GB 15577-2018 粉尘防爆安全规程

## 7-16 NEPSI Flameproof

### NEPSI 隔爆认证

#### 1. 标志资讯

GYJ24.1020X

Ex db IIC T6 Gb; Ex tb IIIC T85°C Db

#### 2. 适用的标准

-GB/T 3836.1-2021

-GB/T 3836.2-2021

-GB/T 3836.31-2021

#### 3. 产品安全使用特殊条件

防爆合格证号后缀“X”表明产品具有安全使用特殊条件，具体内容如下：

1. 涉及安装、维护、维修时需咨询制造厂，索取并参考带有隔爆面参数的文件。
2. 紧固螺钉的性能等级为 A2-70 或 A4-70。
3. 使用环境温度范围：-30°C ~ +75°C。

#### 4. 产品使用注意事项

1. 产品设有外接地端子，用户在安装使用时应可靠接地。
2. 产品电缆引入口须配用经国家指定的检验机构认可的、符合国家标准 GB/T 3836.1-2021、GB/T 3836.2-2021 和 GB/T 3836.31-2021 规定的、螺纹规格为 M20×1.5 或 1/2-14NPT、具有防爆等级为 Ex db IIC Gb; Ex tb IIIC 的电缆引入装置或封堵件，方可用于爆炸性危险场所。该电缆引入装置或封堵件的使用必须符合使用说明书的要求。冗余电缆引入口应有效封堵。电缆引入装置或封堵件安装后，须确保设备整体外壳防护等级不低于 IP66。
3. 现场使用和维护时，必须遵循“严禁带电开盖”的原则。
4. 用户不得自行更换该产品的零部件，应会同产品制造商共同解决运行中出现的故障，以杜绝损坏现象的发生。
5. 用户应当保持产品外壳表面清洁，以防粉尘堆积，但严禁用压缩空气吹扫。
6. 产品的安装、使用和维护应同时遵守产品说明书及下列相关标准、规范的要求：
  - GB/T 3836.13-2021 爆炸性环境 第13 部分：设备的修理、检修、修复和改造
  - GB/T 3836.15-2017 爆炸性环境 第15 部分：电气装置的设计、选型和安装
  - GB/T 3836.16-2022 爆炸性环境 第16 部分：电气装置的检查与维护
  - GB 50257-2014 电气装置安装工程爆炸和火灾危险环境 电气装置施工及验收规范
  - GB 15577-2018 粉尘防爆安全规程







# Appendix A LUI Display Example

## Normal monitor

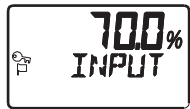
Guide number	Display	Reading	Item	Remarks
1-1		70.0	Opening	Displays the item value in percentage.
		TRAVEL		Valve opening
1-2		70.0	Input signal	Displays the item value in percentage.
		SP		SetPoint
1-3	-	-	-	-
		-		-
1-4		192.0	Output air pressure OUT1	Displays the item value in kPa.
		Po1_kPa		Pressure OUT1 (kPa)
1-5		0.0	Output air pressure OUT2	Displays the item value in kPa.
		Po2_kPa		Pressure OUT2 (kPa)
1-6		270.0	Supply air pressure Ps	Displays the item value in kPa.
		Ps_kPa		Pressure Supply (kPa)

## Details monitor

Guide number	Display	Reading	Item	Remarks
2-1		1.0	Software version	Displays the item value. (The initial setting is the same as that on the seal affixed on the case.)
		S/W_VER		Software Version
2-2		TUNE	Control parameters	Tuning Parameter
		1-L		Left: Actuator Size Right: Friction Level (Initial setting value: 2-L)
2-3		23.5	Electronic substrate temperature	Displays the item value in degrees.
		PWATEMP		Substrate temperature
2-4		56.5	Electropneumatic transduction module Driving current	Displays the item value in percentage.
		EPM_DRV		EPM Drive Signal (EPM: Electropneumatic transduction module)
2-5		150.5	Electropneumatic transduction module Output air pressure	Displays the item value in kPa.
		Pn_kPa		Pressure Nozzle back in EPM (kPa)

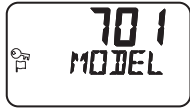







Guide number	Display	Reading	Item	Remarks
2-6		70.0	Input %	Displays the item value in percentage.
		INPUT		Input Signal
2-7		70.1	Opening (Reverse transduction of flow amount characteristic)	Displays the item value in percentage.
		POS		Position
2-8		O_TYP	Single-acting/ double-acting	Output Type
		SINGLE (single-acting) DOUBLE (double-acting)		SINGLE: Single-acting DOUBLE: Double-acting Set during auto setup. (Initial setting: SINGLE)
2-9		P_ACT	Forward/reverse	Positioner Action
		DIRECT (forward) REVERSE (reverse)		DIRECT: Forward REVERSE: Reverse Set during auto setup. (Initial setting: DIRECT)
2-10		15.3	Angle when the valve opening is 0%	Displays the item value in degrees.
		0%.DEG		0% angle (Degree)
2-11		13.2	Angle when the valve opening is 0%	Displays the item value in degrees.
		100%.DEG		100% angle (Degree)
2-12		701	Basic model number	___ of basic model number AVP___
		MODEL		Basic model number

### Status monitor



Guide number	Display	Reading	Item	Remarks
3-1		SS_00	Status	SS: StatusSummary Numerical value: Status category
		0x01		0x: Hexadecimal format Numerical value: Details of status

## Setup mode

### Auto setup

Guide number	Display	Reading	Item	Remarks
7-1		ASU	ASU initial screen	Auto SetUp
		60s		Time until the setup mode automatically ends (Not displayed if the time is longer than 60 seconds.)
7-2		ASU	Waiting for ASU execution	Auto SetUp
		START→→		To perform auto setup, hold down the  button.
7-3		ASU	ASU is being performed.	Auto SetUp
		RUNNING		Flashes.
7-4		ASU	Waiting until ASU stops.	Auto SetUp
		STOP→→		To abort auto setup, hold down the  button.
7-5		80.5	ASU monitor	Valve opening (%)
		208.5kPa		Output air pressure OUT1
7-6		ASU	ASU successfully completed	Auto SetUp
		SUCCESS		
7-7		ASU	ASU failed	Auto SetUp
		FAIL_01		The numerical value is an error code.

### Zero span adjustment





Guide number	Display	Reading	Item	Remarks
8-1		ADJ	ADJ initial screen	Angle Adjustment
		60s		Time until the setup mode automatically ends (Not displayed if the time is longer than 60 seconds.)
8-2		AJ100 (AJ 0)	ADJ adjustment opening selection	AJ100 : Adjust 100% Angle (AJ 0 : Adjust 0% Angle)
		→		

Guide number	Display	Reading	Item	Remarks
8-3		AJ100 (AJ 0)	ADJ adjustment angle selection	AJ100 : Adjust 100% Angle (AJ 0 : Adjust 0% Angle)
		COARSE→ MID → FINE →		Angle adjusted by operating the button once COARSE : 1° MID : 0.1° FINE : 0.01°
8-4		97.5	ADJ is being adjusted	Valve opening (%)
		AJ100% (AJ 0%)		AJ100% : Adjust 100% Angle (AJ 0% : Adjust 0% Angle)
8-5		99.8	ADJ monitor	Valve opening (%)
		235.0kPa		Output air pressure OUT1
8-6		ST 0 ST100	ADJ Manual Setting adjustment opening selection	ST 0 : Set 0% angle ST100 : Set 100% angle
		→		
8-7		ST 0 ST100	Waiting until ADJ Manual Setting is performed	ST 0 : Set 0% angle ST100 : Set 100% angle
		OK?→→		To perform manual setting, hold down the  button.
8-8		ST 0 ST100	ADJ Manual Setting completed	ST 0 : Set 0% angle ST100 : Set 100% angle
		SUCCESS		





### Supply bypass

Guide number	Display	Reading	Item	Remarks
9-1		BPS	BPS initial screen	Supply Bypass
		60s		Time until the setup mode automatically ends (Not displayed if the time is longer than 60 seconds.)
9-2		BPS	BPS pressure selection	Supply Bypass
		: P_MIN→→ : P_MAX→→		To perform the selected supply bypass, hold down the button.
9-3		BPS	BPS execution	Supply Bypass
		: RUN_MIN : RUN_MAX		Flashes.







Guide number	Display	Reading	Item	Remarks
9-4		BPS	BPS stop selection	Supply Bypass
		CLEAR→→		To abort the supply bypass, hold down the  button.
9-5		BPS	BPS stop completed	Supply Bypass
		CLEARED		
9-6		BPS	BPS execution impossible	Supply Bypass
		FAIL_01		The numerical value is an error code.

### Control parameters

Guide number	Display	Reading	Item	Remarks
11-1		TUNE	Control parameter initial screen	Tuning Parameter
		60s		Changes depending on the time until the setup mode automatically ends [Longer than 60 seconds] Current control parameter [60 seconds or less] Time until the setup mode automatically ends (in seconds)
11-2		TUNE	Control parameter selection	Tuning Parameter
		1-L		To change control parameters, hold down the  button.
11-3		TUNE	Control parameter check	Tuning Parameter
		1-L		

### Configuration

Guide number	Display	Reading	Item	Remarks
12-1		CONF	Actuator Type and Valve Closed Position specification initial screen	Valve Configuration
		60s		Lower section: Time until the setup mode automatically ends (Not displayed if the time is longer than 60 seconds.)
12-2		A_TYPE	Actuator Type specification screen	Actuator Type
		LINEAR R 90 R OTH R_S 90 R_S OTH		Flashes. LINEAR: Linear valve R 90: Rotary valve with an operating angle of 90° R OTH: Rotary valve with an operating angle other than 90° R_S 90: Rotary sub valve with an operating angle of 90° R_S OTH: Rotary sub valve with an operating angle other than 90°
12-3		CLS_P	Valve Closed Position specification screen	Valve Closed Position
		UP DOWN		Flashes.
12-4		A_TYPE	Actuator Type confirmation screen	Actuator Type
		LINEAR R 90 R OTH R_S 90 R_S OTH		Same as 12-2. (Does not flash.)
12-5		CLS_P	Valve Closed Position confirmation screen	Valve Closed Position
		UP DOWN		

# Appendix B Menu List

## Menu List

Menu			
<b>Process Variables</b>			
Process Variables			
	Input (mA)		
	Input (%) *1		
	Set Point (SP)		
	Travel		
	Position *1		
	Drive Signal		
	Po 1		
	Po 2 *2		
	Ps		
	Pn		
	Temperature		
<b>Device</b>			
	<b>Basic Setup</b>		
		Auto Setup	
		Travel Angle 100%	
		Travel Angle 0%	
		Stroke Time Open	
		Stroke Time Closed	
		Stroke Time Average	
		Friction Index	
		Initial Supply Pressure	
		Spring Range High	
		Spring Range Low	
		Drive Sig Range High	
		Drive Sig Range Low	
		Drive Sig-Pn Gain	
		Drive Sig-Pn Intercept	
	<b>Configuration</b>		
		<b>Operator Action Setting</b>	
			Using Operator
			Allow operator action
			Forbid operator action
		<b>Input Range</b>	
			Input Range High (Open/100%)
			Input Range Low (Closed/0%)
		<b>Valve System</b>	
			Actuator Type
			Valve Closed Position
			Feedback Lever Motion
			Pilot Relay Type
			Positioner Action
			Electrical Fail To
			Air Fail To
		<b>Control Configuration</b>	
			Actuator Size
			Friction Level *4
			Control Deadband
			Replace Control Parameters *5
			Control Parameters *5
			P Outside of GAP1 *5
			I Outside of GAP1 *5
			D Outside of GAP1 *5
			GAP1 *5
			P Inside of GAP1 *6
			I Inside of GAP1 *6
			D Inside of GAP1 *6
			GAP2 *6
			P Inside of GAP2 *7
			I Inside of GAP2 *7
			D Inside of GAP2 *7
		<b>Input Characterization</b>	
			Input Characterization
		<b>Custom Curve Data *8</b>	
			Custom Data IN 1 *8
			Custom Data IN 21 *8
			Custom Data OUT 1 *8
			Custom Data OUT 21 *8
		<b>Travel Cutoff</b>	
			Travel Cutoff High
			Travel Cutoff Low
		<b>Unit</b>	
			Unit of Pressure

		Change Unit of Pressure	
	Maintenance		
		Travel Calibration	
		Auto Travel Calibration	
		Angle Correction	
		Manual Setting	
		Change Travel Angle	
		Input Calibration	
		Calibrate 4 mA signal	
		Calibrate 20 mA signal	
		Pressure Sensor Adjustment	
		Zero Adjustment	
		Simulation	
		Dummy Input Signal	
		Dummy Drive Signal	
		Pneumatic Modules	
		Pilot Adjustment *2	
		EPM Adjustment *10	
		Restore factory settings	
		Restore factory settings	
		Operator Action Records	
		Operator Action Records	
		Real Time Clock	
		Current Date (MM/DD/YYYY)	Note 3
		Current Time	
		Set Real Time Clock	
		Password	
		Password Use	
		Change password use setting	
		Change Password *11	
	Device Information		
		Manufacturer	
		Model	
		Device ID	
		Device Tag	
		Long Tag	
		Date (MM/DD/YYYY)	Note 3
		Descriptor	
		Message	
		Serial Number	
		Final Assembly Number	
		Distributor	
		Config Change Counter	
		Operating Time	
		Polling Address	
		Number of Request Preambles	
		Number of Response Preambles	
		Revision Numbers	
		HART Version	
		Device Revision	
		Software Revision	
		Hardware Revision	
		Factory Setting Information	
		Production Number	
		Model Number	
		Valve Model Number	
		Factory Setting Date (MM/DD/YYYY)	Note 3
	Option		
		Travel Transmission (AO) *12	
		Travel Transmission *12	
		Dummy Travel Transmission *12	
		Fail Safe Direction *12	
		D/A Trim *12	
	Review		
		* Refer to "1) MENU (Review)".	
	Diagnostics		
		Diagnostic Status	
		Positioner Diagnostic	
		Failure	
			Valve Travel Detector Failure
			Valve Travel Detector Out of Range
			Po 1 Pressure Sensor Failure
			Po 2 Pressure Sensor Failure
			Ps Pressure Sensor Failure
			Pn Pressure Sensor Failure

				Temperature Sensor Failure
				CPU Failure
				RAM Failure
				ROM Failure
				A/D Conversion Module 1 Failure
				A/D Conversion Module 2 Failure
				Non-Volatile Memory Failure
				Input Circuit Failure
				Internal Program Execution Error
			Function Check	
				Local User I/F Active
				Dummy Input Signal is running
				Dummy Drive Signal is running
				Dummy Travel Transmission is running *12
				Auto Setup is running
				Auto Travel Calibration is running
				Step Responce Test is running
				Valve Signature is running
			Out of Specification	
				VTD Angle Span Out of Range
				Supply Pressure Out of Range
				Temperature Out of Range
				Input Signal Low
				Insufficient Input Signal Range
				Incorrect Setting of Input Range
			Maintenance Required	
				Restriction is clogged
				Deposits on the Nozzle-Flapper
			Information	
				Travel Cutoff High
				Travel Cutoff Low
				Factory Settings Restored
				In Use by an Operator
				Local User I/F Abnormal
				Local User I/F was used in past 10 min.
				Failure Output (AO) *12
		Valve Diagnostic		
			Out of Specification	
				Supply Pressure High Alarm
				Supply Pressure Low Alarm
				Temp High Alarm
				Temp Low Alarm
			Maintenance Required	
				Stick-Slip High Alarm
				Stick-Slip Medium Alarm
				Stick-Slip Low Alarm
				Zero Travel + Alarm
				Zero Travel - Alarm
				Deviation + Alarm
				Deviation - Alarm
				Po Validity + Alarm
				Po Validity - Alarm
				Max Friction Alarm
				Total Stroke Alarm
				Cycle Count Alarm
				Shut Count Alarm
				Max Tvl Speed + Alarm
				Max Tvl Speed - Alarm
	Diagnostic Status Records			
		Positioner Diagnostic		
		Valve Diagnostic		
	Diagnostic Setup			
		Positioner Air Circuit		
			Drive Sig Max Shift +	
			Drive Sig Max Shift -	
			Update Drive Sig Max Shift	
			Reset Drive Sig Max Shift	

			Drive Sig Shift Threshold + (Default value 25%)	
			Drive Sig Shift Threshold - (Default value 25%)	
			Drive Sig Stable Threshold	
			Pn Stable Threshold	
			Drive Sig + Alarm Count	
			Drive Sig - Alarm Count	
			Update Drive Sig Alarm Count	
			Positioner Air Circuit Alarm Enabled (Select the alarm enable or alarm disable of "Restriction is clogged" and "Deposits on the Nozzle-Flapper.)	
		Stick-Slip		
			Stick-Slip X	
			Stick-Slip Y	
			Stick-Slip Validity	
			Stick-Slip Updated Date (MM/DD/YYYY)	
			Stick-Slip Updated Time	
			Update Stick-Slip	
			Stick-Slip High Alarm Count	
			Stick-Slip Medium Alarm Count	
			Stick-Slip Low Alarm Count	
			Update Stick-Slip Alarm Count	
			Stick-Slip Threshold High (Default value 10)	
			Stick-Slip Threshold Medium (Default value 5.5)	
			Stick-Slip Threshold Low (Default value 3)	
			Stick-Slip Alarm Enabled	
		Zero Travel		
			Zero Travel Max	
			Zero Travel Min	
			Update Zero Travel Max/Min	
			Reset Zero Travel Max/Min	
			Zero Travel Stable Threshold	
			Zero Travel Static Time	
			Zero Travel Error Waiting Time (Default value 10s)	
			Zero Travel Threshold + (Default value 1%)	
			Zero Travel Threshold - (Default value -3%)	
			Zero Travel Waiting Time (Default value 40s)	
			Zero Travel + Alarm Count	
			Zero Travel - Alarm Count	
			Update Zero Travel Alarm Count	
			Zero Travel Alarm Enabled	
		Deviation		
			Deviation Time Max +	
			Deviation Time Max -	
			Update Deviation Time Max	
			Reset Deviation Time Max	
			Deviation Threshold + (Default value 5%)	
			Deviation Threshold - (Default value -5%)	
			Deviation Waiting Time (Default value 10s)	
			Deviation + Alarm Count	
			Deviation - Alarm Count	
			Update Deviation Alarm Count	
			Deviation Alarm Enabled	
		Supply Pressure		
			Sup Press Max	
			Sup Press Min	
			Update Sup Press Max/Min	
			Reset Sup Press Max/Min	
			Sup Press Threshold High Note 1	
			Sup Press Threshold Low Note 1	

			Sup Travel Stable Threshold	
			Sup Travel Stable Time	
			Sup Press High Alarm Count	
			Sup Press Low Alarm Count	
			Update Sup Press Alarm Count	
			Sup Press Alarm Enabled	
		<b>Temperature</b>		
			Temp Max	
			Temp Min	
			UpdateTemp Max/Min	
			Reset Temp Max/Min	
			Temp Threshold High (Default value 80 degrees C)	
			Temp Threshold Low (Default value -40 degrees C)	
			Temp High Alarm Count	
			Temp Low Alarm Count	
			UpdateTemp Alarm Count	
			Temp Alarm Enabled	
		<b>Force Balance</b>		
			Po Validity	
				Po Validity +
				Po Validity -
				Unbalance Force Seg 1
				Unbalance Force Seg 26
				Update Unbalance Force
				Po Validity Threshold + Note 1
				Po Validity Threshold - Note 1
				Po Validity Alarm Enabled
		<b>Max Friction</b>		
				Max Friction
				Friction Seg 1
				Friction Seg 26
				Update Friction
				Max Friction Threshold Note 1
				Max Friction Alarm Enabled
		<b>Common Parameters</b>		
				Po Max Seg 1
				Po Max Seg 26
				Po Min Seg 1
				Po Min Seg 26
				Update Po Max/Min
				Travel Seg Divider 1
				Travel Seg Divider 25
				Po Stable Threshold
				Travel Stable Threshold
				Travel Upper Limit
				Travel Lower Limit
			Reset Force Balance	
		<b>Total Stroke</b>		
			Total Stroke	
			Update Total Stroke	
			Total Stroke Dead Band	
			Total Stroke Threshold (Default value 2000000%)	
			Total Stroke Alarm Enabled	
		<b>Cycle Count</b>		
			Cycle Count	
			Update Cycle Count	
			Cycle Count Dead Band High	
			Cycle Count Dead Band Low	
			Cycle Count Threshold (Default value 100000)	
			Cycle Count Alarm Enabled	
		<b>Shut Count</b>		
			Shut Count	
			Update Shut Count	
			Shut Count Threshold (Default value 100000)	
			Shut Count Alarm Enabled	
		<b>Max Travel Speed</b>		
			Max Tvl Speed +	
			Max Tvl Speed -	
			Update Max Tvl Speed	

			Reset Max Tvl Speed	
			Max Tvl Speed Threshold + (Default value +1000%/s)	
			Max Tvl Speed Threshold - (Default value -1000%/s)	
			Max Tvl Speed Alarm Enabled	
		Travel Histogram		
			Travel Histogram	
				Travel Histogram 1
				Travel Histogram 26
				Update Travel Histogram
				Reset Travel Histogram
			Travel Segmentation	
				Travel Seg Divider 1
				Travel Seg Divider 25

Note 1: These parameters are updated when the auto setup is carried out.

Note 2: When '1.\$', '<<<', '>>>' or '1.#INF' is displayed, the value is non-numeric character or infinite.

Note 3: The order of 'MM/DD/YYYY' can be changed with the host or PC configuration.

- \*1. Display except for "Linear" of Input Characterization
- \*2. Display in case of "Double Acting" of Pilot Relay Type
- \*4. Display in case of Param 1, 2 3, 4, 5, or 6 of Actuator Size
- \*5. Display in case of "Custom" of Actuator Size
- \*6. Display in case of "Custom" or "GAP1≠0.00" of Actuator Size
- \*7. Display in case of "Custom", "GAP1≠0.00" or "GAP1≠0.00"of Actuator Size
- \*8. Display in case of "Custom Curve" of Input Characterization
- \*10. Please ask our service engineer to carry out this operation.
- \*11. Display in case of "Enabled" of Password Use
- \*12. Display in case of AVP701
- \*13. Display in case of only EDD
- \*14. Display in case of only DD



## 1) MENU (Review)

Displayed parameters and their order are as shown below.

Manufacturer
Model
Device ID
Device Tag
Long Tag
Date
Descriptor
Message
Serial Number
Final Assembly Number
Distributor
Config Change Counter
Operating Time
Polling Address
Number of Request Preambles
Number of Response Preambles
HART Version
Device Revision
Software Revision
Hardware Revision
Production Number
Model Number
Valve Model Number
Factory Setting Date
Input (mA)
Input (%) *1
Set Point (SP)
Travel
Position *1
Drive Signal
Po 1
Po 2 *2
Ps
Pn
Temperature
VTD Angle
Travel Angle 100%
Travel Angle 0%
Stroke Time Open
Stroke Time Closed
Stroke Time Average
Friction Index
Initial Supply Pressure
Spring Range High
Spring Range Low
Drive Sig Range High
Drive Sig Range Low
Drive Sig-Pn Gain
Drive Sig-Pn Intercept
Input Range High (Open/100%)
Input Range Low (Closed/0%)
Actuator Type
Valve Closed Position
Feedback Lever Motion
Pilot Relay Type
Positioner Action
Electrical Fail To
Air Fail To
Actuator Size
Friction Level *4
Control Deadband
P Outside of GAP1 *5
I Outside of GAP1 *5
D Outside of GAP1 *5
GAP1 *5
P Inside of GAP1 *6
I Inside of GAP1 *6

D Inside of GAP1 *6
GAP2 *6
P Inside of GAP2 *7
I Inside of GAP2 *7
D Inside of GAP2 *7
Input Characterization
Custom Data IN 1 *8
Custom Data IN 21 *8
Custom Data OUT 1 *8
Custom Data OUT 21 *8
Travel Cutoff High
Travel Cutoff Low
Unit of Pressure
Password Use
Travel Transmission *12
Fail Safe Direction *12

- \*1. Display except for "Linear" of Input Characterization
- \*2. Display in case of "Double Acting" of Pilot Relay Type
- \*4. Display in case of Param 1, 2 3, 4, 5, or 6 of Actuator Size
- \*5. Display in case of "Custom" of Actuator Size
- \*6. Display in case of "Custom" or "GAP1≠0.00" of Actuator Size
- \*7. Display in case of "Custom", "GAP1≠0.00" or "GAP1≠0.00" of Actuator Size
- \*8. Display in case of "Custom Curve" of Input Characterization
- \*12. Display in case of AVP701

# Appendix C Specification

## LIST OF FEATURES

Item	Function
Desired input signal range	Any split-range value can be specified.
Forced fully open/closed	The control valve can be fully closed or opened securely when the desired percentage of input signal is reached.
Desired flow characteristics	The relationship between input signal and valve travel that is appropriate for the process can be defined by using a 21-point line graph.
Travel transmission (option)	Valve motion can be reliably monitored by transmitting the valve travel.

## FUNCTIONAL SPECIFICATIONS

Item	Specification	
Applicable actuator	Pneumatic single and double acting, linear and rotary motion actuator	
Input signal	4 to 20 mA DC (Configurable to any required range for split range: minimum span 4 mA DC) Minimum driving current: 3.84 mA	
Output signal	4 to 20 mA DC (Travel transmission)	
Input resistance	475 Ω typically / 20 mA DC (Without the overvoltage protection) 600 Ω typically / 20 mA DC (With the overvoltage protection)	
Lightning protection	Peak value of voltage surge: 12 kV Peak value of current surge: 1000 A	
Flow characteristics	Linear, Equal percentage, Quick opening Custom user characteristics (21 points)	
Manual operation	Auto/Manual external switch or LUI (Local User Interface) (Not available double acting actuator)	
Supply air pressure	140 to 700 kPa	
Air consumption	for single acting actuator 3.2 L/min [N] or less: with steady supply air pressure of 140 kPa {1.4 kgf/cm <sup>2</sup> } and output of 50 % 4.0 L/min [N] or less: with steady supply air pressure of 280 kPa {2.8 kgf/cm <sup>2</sup> } and output of 50 % 4.8 L/min [N] or less: with steady supply air pressure of 500 kPa {5.0 kgf/cm <sup>2</sup> } and output of 50 %  for double acting actuator 8 L/min (N) or less: at air pressure of 400 kPa {4.0 kgf/cm <sup>2</sup> } and balanced output pressures at a steady 70 % of the supply air pressure	
Maximum air deliver flowrate	110 L/min (N) at 140 kPa {1.4 kgf/cm <sup>2</sup> }	
Air connections	Rc1/4 or 1/4NPT internal thread	
Electrical connections	G1/2, 1/2NPT or M20 × 1.5 internal thread	
Ambient temperature limits	-40 to +80 °C for general model TIIS Flameproof: -20 to +55 °C FM/FMC/IECEX/CCC/KCs/CNS Explosion protection: -30 to +75 °C FM/Intrinsically safe (ic) and Nonincendive: -24 to +75 °C ATEX/IECEX/CCC/CNS Intrinsically safe: -40 to +60 °C LCD operating limit: 0 to +50 °C	
Ambient humidity limits	5 to 100 %RH	
Vibration characteristics	20 m/s <sup>2</sup> , 5 to 400 Hz (with standard mounting kit on Azbil Corporation's HA actuator)	
Color	Silver	
Material	Cast aluminum	
Weight	Without Pressure regulator with filter: 4.2 kg With Pressure regulator with filter model RA1B: 4.7 kg With Pressure regulator with filter model KZ03: 4.9 kg	
Performance	Accuracy	±1.0% F.S. But: ±3.0 % FS if the feedback lever angle is outside the ±4° to ±20° range (see Table 1) There is an additional 0.5 % FS (input error) if 4 mA ≤ input signal span < 8 mA
	Travel transmission accuracy	±1.0 %F.S.*1
	Stroke coverage	14.3 to 100 mm Stroke (Feedback Lever Angle ±4° to ±20°)
Structure	TIIS Flameproof      Ex d IIC T6 X  FM Explosionproof/Dust Ignition Protection Explosionproof (Division system): Class I, Division 1, Group B, C, D T6 <ul style="list-style-type: none"> <li>• Factory sealed, conduit seal not required</li> <li>• Not including gasoline atmospheres</li> </ul> Flameproof (Zone system): Class I, Zone 1, AEx d IIC T6 Gb Dust ignition protection (Division system): Class II, III, Division 1, Group E, F, G T6 Dust ignition protection (Zone system): Zone 21 AEx tb IIIC T85 °C Db Enclosure classification: IP66	

\*1. This applies only to positioners with travel transmission (model AVP701). In this case, a power supply circuit for travel transmission is required.

Item	Specification
Structure	<p>FM Intrinsically safe (ic) and Nonincendive</p> <p>Intrinsically safe (ic) (Zone system)  Class I, Zone 2, AEx ic IIC T4  Entity Parameters:  Positioner Circuit: <math>U_i=30\text{ V}</math>, <math>I_i=100\text{ mA}</math>, <math>P_i=1\text{ W}</math>, <math>C_i=24\text{ nF}</math>, <math>L_i=0.22\text{ mH}</math>  Transmitter Circuit (AVP701): <math>U_i=30\text{ V}</math>, <math>I_i=100\text{ mA}</math>, <math>P_i=1\text{ W}</math>, <math>C_i=20\text{ nF}</math>, <math>L_i=0.22\text{ mH}</math></p> <p>Nonincendive (Division system)  Class I, Division 2, Group A, B, C and D, T4  Nonincendive Field Wiring Parameters:  Positioner Circuit: <math>V_{\text{max}}=30\text{ V}</math>, <math>I_{\text{max}}=100\text{ mA}</math>, <math>C_i=24\text{ nF}</math>, <math>L_i=0.22\text{ mH}</math>  Transmitter Circuit (AVP701): <math>V_{\text{max}}=30\text{ V}</math>, <math>I_{\text{max}}=100\text{ mA}</math>, <math>C_i=20\text{ nF}</math>, <math>L_i=0.22\text{ mH}</math></p> <p>Suitable  Class II and Class III, Division 2, Group E, F and G, T4  Indoor/Outdoor Enclosure: NEMA Type 4X, IP66</p> <p>FMC Explosionproof/Dust Ignition Protection</p> <p>Explosionproof (Division system): Class I, Division 1, Group C, D T6</p> <ul style="list-style-type: none"> <li>• Factory sealed, conduit seal not required</li> <li>• Not including gasoline atmospheres</li> </ul> <p>Flameproof (Zone system): Class I, Zone 1, Ex d IIB T6</p> <ul style="list-style-type: none"> <li>• Seal all conduits within 450 mm (18 inches)</li> </ul> <p>Dust ignition protection (Division system): Class II, III, Division 1, Group E, F, G T6  Enclosure classification: IP66</p> <ul style="list-style-type: none"> <li>• The wiring conduit cable gland and electrical wiring must be compliant with the National Electrical Code (NEC).</li> </ul> <p>ATEX Intrinsically safe/Dust Ignition Protection</p> <p>Intrinsically safe: II 1 G Ex ia IIC T4 Ga  Dust ignition protection: II 1 D Ex ia IIIC T135°C Da  Enclosure classification: IP66  The barriers should be ATEX certified types and comply with the following conditions:  Input Signal Terminals (+/-IN):  <math>U_i=30\text{ V}</math>, <math>I_i=93\text{ mA}</math>, <math>P_i=0.9\text{ W}</math>, <math>C_i=4\text{ nF}</math>, <math>L_i=220\text{ }\mu\text{H}</math>  Output Signal Terminals (+/-OUT):  (AVP701) <math>U_i=30\text{ V}</math>, <math>I_i=93\text{ mA}</math>, <math>P_i=0.9\text{ W}</math>, <math>C_i=22\text{ nF}</math>, <math>L_i=220</math></p> <p>IECEX Flameproof/Dust Ignition Protection</p> <p>Flameproof: Ex d IIC T6 Gb  Dust ignition protection: Ex tb IIIC T85°C Db  Enclosure classification: IP66  Please use IECEX Ex d IIC-approved products as the cable gland for connecting it to the electrical connection port.  However, please use IP66-approved products when using it in an environment that requires IP66.</p> <p>IECEX Intrinsically safe/Dust Ignition Protection</p> <p>Intrinsically safe: Ex ia IIC T4 Ga  Dust ignition protection: Ex ia IIIC T135°C Da  Enclosure classification: IP66  The barriers should be IECEX certified types and comply with the following conditions:  Input Signal Terminals (+/-IN):  <math>U_i=30\text{ V}</math>, <math>I_i=93\text{ mA}</math>, <math>P_i=0.9\text{ W}</math>, <math>C_i=4\text{ nF}</math>, <math>L_i=220\text{ }\mu\text{H}</math>  Output Signal Terminals (+/-OUT):  (AVP701) <math>U_i=30\text{ V}</math>, <math>I_i=93\text{ mA}</math>, <math>P_i=0.9\text{ W}</math>, <math>C_i=22\text{ nF}</math>, <math>L_i=220\text{ }\mu\text{H}</math></p> <p>CCC Flameproof / Dust Ignition Protection</p> <p>Flameproof: Ex db IIC T6 Gb -30°C <math>\leq T_{\text{amb}} \leq</math> +75°C IP66  Dust ignition protection: Ex tb IIIC T85°C Db  Enclosure classification: IP66  For the cable gland connected to the electrical connection port, use products with CCC Ex db IIC or Ex tD A21 explosion-proof certification.  Please use IP66-approved products in an environment that requires IP66.</p> <p>CCC Intrinsically safe/Dust Ignition Protection</p> <p>Intrinsically safe: Ex ia IIIC T4 Ga  Dust ignition protection: Ex ia IIIC T<sub>200</sub> 135°C Da  Enclosure classification: IP66  The barriers should be CCC certified types and comply with the following conditions:  Input Signal Terminals (+/- IN):  <math>U_i=30\text{ V}</math>, <math>I_i=93\text{ mA}</math>, <math>P_i=0.9\text{ W}</math>, <math>C_i=4\text{ nF}</math>, <math>L_i=220\text{ }\mu\text{H}</math>  Output Signal Terminals (+/- OUT):  (AVP701) <math>U_i=30\text{ V}</math>, <math>I_i=93\text{ mA}</math>, <math>P_i=0.9\text{ W}</math>, <math>C_i=22\text{ nF}</math>, <math>L_i=220\text{ }\mu\text{H}</math></p> <p>KCs Flameproof</p> <p>Ex d IIC T6  Please use KCs Ex d IIC-approved products as the cable gland to be connected to the electrical connection port.</p>

Item	Specification
Structure	<p>CNS Flameproof</p> <p>Flameproof: Ex d IIC T6 Gb Enclosure classification: IP66 For the cable gland connected to the electrical connection port, use products with CNS Ex d IIC explosion-proof certification. Please use IP66-approved products in an environment that requires IP66.</p> <p>CNS Intrinsically safe/Dust Ignition Protection</p> <p>Intrinsically safe: Ex ia IIC T4 Ga Dust ignition protection: Ex ia IIIC T135 °C Da Enclosure classification: IP66 The barriers should be CCC certified types and comply with the following conditions: Input Signal Terminals (+/- IN): Ui=30V, li=93mA, Pi=0.9W, Ci=4nF, Li=220uH Output Signal Terminals (+/- OUT): (AVP701) Ui=30V, li=93mA, Pi=0.9W, Ci=22nF, Li=220uH</p>
CE conformity	<p>Electromagnetic compatibility EN61326-1: 2013 (CE Marking)</p> <p>The device is intended for use in industrial locations defined in CE marking directive (EN 61326-1).</p>

Note: Depending on the inner diameter and length of the air pipe, automatic setup might not be sufficient to realize the optimum operation. In such a case, please specify the relevant parameters.

### Conditions of supply air (JIS C1805-1 (2001))

Item	Specification
Particles	Maximum diameter 3 μmm
Oil mist	Less than 1 ppm at mass
Humidity of the air supply	The dew point should be at least 10°C lower than the temperature of this device.

To meet the above specifications for instrument air, install the air purification devices listed below properly in the specified installation location.

### Examples of air purification devices

Installation	Air purification device	SMC corporation	CKD corporation
Compressor outlet or main line	Line filter	AFF series	AF series
	Mist separator	AM series	
Terminal device	Mist separator	AM150 or AM250 series	M3000S type

**Table 1. Standard travel range and accuracy**

Actuator	Travel (mm)	Accuracy [% F.S.]
PSA1, 2	14.3, 20, 25	1.0
PSA3, 4	20, 38	1.0
HA1	6, 8, 10	3.0
	14.3, 25	1.0
HA2	10	3.0
	14.3, 25, 38	1.0
HA3	14.3	3.0
	25, 38, 50	1.0
HA4	14.3	3.0
	25, 38, 50, 75	1.0
VA5	25, 37.5, 50, 75, 100	1.0
VA6	14.3	3.0
PSA6, 7	25, 37.5, 50, 75, 100	1.0
HK1	10	3.0
	PSK1	19
DAP560, 1000 1000X	14.3	3.0
	25~100	1.0
DAP1500, 1500X	14.3, 25	3.0
	38~100	1.0



# Appendix D Model Selection

## MODEL SELECTION

### Basic model number

		(1)	(2)	(3)	(4)	(5)	(6)	(7)	(8)	(9)
AVP701	Analog signal (4 to 20 mA DC) with Travel Transmission and HART communication Protocol									
AVP702	Analog signal (4 to 20 mA DC) with HART communication Protocol									
(1) Structure	Water-proof	X								
	TIIS Flameproof (Electrical connection G1/2 only) with cable gland *1	E								
	FM Explosionproof/Dust ignition protection (Electrical connection G1/2 is not available.)	F								
	FM Intrinsically safe (ic) and Nonincendive	V								
	FMC Explosionproof/Dust ignition protection (Electrical connection G1/2 is not available.)	A								
	ATEX Intrinsically safe/Dust Ignition Protection	L								
	IECEx Flameproof/Dust ignition protection (Electrical connection G1/2 is not available.)	D								
	IECEx Intrinsically safe/Dust Ignition Protection	T								
	CCC Flameproof/Dust ignition protection (Electrical connection G1/2 is not available.)	N								
	CCC Intrinsically safe/Dust Ignition Protection	R								
	KCs Flameproof (Electrical connection G1/2 is not available.)	K								
	CNS Flameproof (Electrical connection G1/2 is not available.)	S								
CNS Intrinsically safe/Dust Ignition Protection	H									
(2) Connection	Electrical connection   Air piping connection   Mounting thread   Pressure gauge thread									
	G1/2   Rc1/4   M8   Rc1/8	G								
	1/2NPT   1/4NPT   M8   Rc1/8	N								
	M20×1.5   1/4NPT   M8   Rc1/8	M								
(3) Finish	Standard (Baked acrylic)			S						
	Corrosion proof (Baked urethane)			B						
(4) (5) Display	Display with push button				D	X				
(6) Diagnostic	Advanced Diag (with four pressure sensors)						A			
(7) Overvoltage protection	None							X		
	Overvoltage protection (Input impedance +125 )							V		
(8) (9) Option	None								X	X
	Explosion-proof universal elbow (SUS304 G1/2) (1)								A	A
	Explosion-proof universal elbow (SUS304 G1/2) (2)								A	C
	Model RA1B pressure regulator with filter (Mounted on Positioner)*2								M	7
	Model RA1B pressure regulator with filter (with bracket for separated mount)								M	8
	Model RA1B pressure regulator with filter (with bracket for separated mount onto horizontal-installed actuator)								M	9
	Model KZ03 pressure regulator with filter (Mounted on Positioner)*2								M	1
	Model KZ03 pressure regulator with filter (with bracket for separated mount)								M	2
	Model KZ03 pressure regulator with filter (with bracket for separated mount onto horizontal-installed actuator)								M	3
	Extension lever (In case of without mounting bracket)								M	L
	Seal tape prohibited								M	J
	Mounting bracket material SUS316*3								M	6
	Mounting bracket (PSA,1,2,PSK1)								Y	S
	Mounting bracket (New model PSA3, 4 (produced after 2000), VA1 to 3(produced after May. '83))								Y	Q
	Mounting bracket (PSA6, VA4 to 6(produced after May. '83))								Y	L
	Mounting bracket (PSA7)								Y	8
	Mounting bracket (HA1)								Y	A
	Mounting bracket (HA2, HL2)								Y	T
	Mounting bracket (HA3, HL3)								Y	C
	Mounting bracket (HA4, HL4)								Y	N
	Mounting Bracket (VR1)								Y	V
	Mounting Bracket (VR2, 3)								Y	R
	Mounting Bracket (VR3H)								Y	6
	Mounting Bracket (RSA1)								Y	F
	Mounting Bracket (RSA2)								Y	U
	Mounting Bracket (old model PSA3, 4 (those produced before 1999))								Y	Y
	Mounting Bracket (VA1 to 3 (produced before Apr. '83, former model Motion Connector), 800-1, 2, 3)*4								Y	W
Mounting Bracket (VA4,5(produced before Apr. '83, former model Motion Connector), 800-4, 5)*4								Y	J	
Mounting Bracket (VP5,6)								Y	1	
Mounting Bracket (VP7)								Y	7	
Mounting bracket (DAP560, 1000, 1000X (stroke: 100mm max.))								Y	4	
Mounting bracket (DAP1500, 1500X (stroke: 100mm max.))								Y	5	

\*1. One set of TIIS Flameproof cable gland shall be attached for model AVP702. Two sets are for model AVP701.

\*2. Select the code "M7" or "M1" only when the direction of drain of the pressure regulator with filter on the control valve is downward (ground).

\*3. Material of mounting bracket when you don't select code "M6" is SUS304.

\*4. Consult with sales representative in case of no mounting hole on the side of valve yoke.

## Individual specifications

Device TAG No. (8 characters)	Be sure to configure the data.
Long TAG No. (max 32 characters)	Configure the data if necessary.
Input range	4 to 20 mA DC Note: Minimum span 4mA
Input characterization*1	L: Linear EQ%: Equal percentage QO: Quick opening USER: User-defined
Positioner action*2	D: Direct for single acting actuator R: Reverse for single acting actuator W: For double acting actuator
Supply pressure classification	1: $140 \leq P_s \leq 150$ kPa 2: $150 < P_s \leq 300$ kPa 3: $300 < P_s \leq 400$ kPa 4: $400 < P_s \leq 450$ kPa 5: $450 < P_s \leq 700$ kPa
Unit of pressure gauge	A: kPa B: kgf/cm <sup>2</sup> C: MPa D: bar E: psi
Valve closed position	DOWN, UP
Actuator type	L: Linear R90: Rotary 90° R60: Rotary 60° RS90: Rotary sub 90° RS60: Rotary sub 60°
Travel transmitter fail safe direction (Model AVP701 only)	DOWN, UP The setting of failure output direction cannot be changed after delivery.
LCD facing upwards	X: No optional parts A: LCD cover and Pressure gages jointed to elbows B: LCD cover C: Pressure gages jointed to elbows

\*1. Refer to following when selecting the input/ output characteristics.

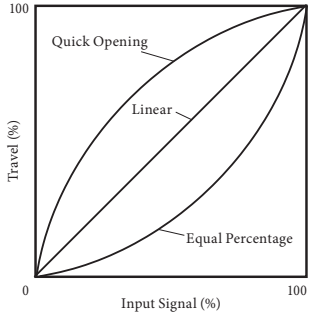

The graph plots Travel (%) on the y-axis (0 to 100) against Input Signal (%) on the x-axis (0 to 100). Three curves are shown: 'Quick Opening' (concave down), 'Linear' (a straight diagonal line), and 'Equal Percentage' (concave up).

**Selection of input characterization**

The flow characteristic of a control valve is set by selecting the valve plug characteristic, and the input-output characteristics of the positioner must be specified as linear. However, if the valve plug flow characteristic, which depends on the control valve's shape and structure, does not meet requirements, you can correct the overall flow characteristic of the control valve by specifying "equal percentage" or "quick opening" for the input-output characteristics of the positioner, as shown in Table 2.

**Table 2. Control valve flow characteristics correction by the positioner**

Characteristic of valve plug	Input characterization of positioner	Overall flow characteristic of control valve
Linear	Quick opening	Quick opening
Linear	EQ%	EQ%
EQ%	Quick opening	Linear

*Note: If the valve plug characteristic is "quick opening," the overall flow characteristic of the control valve cannot be linear even if "equal percentage" is set for the positioner's input-output characteristics. (This is because when the valve plug characteristic is "quick opening," the control valve works as an ON/OFF valve and it is difficult to correct its characteristics by changing the setting of the positioner.)*

\*2. When the power is shut off, select D (Direct for single acting actuator) to make the output air pressure of this device zero, and R (Reverse for single acting actuator) to make the output at the maximum air pressure (supply air pressure). Positioner action differs from actuator and control valve action, so be careful in selecting the positioner's action.



# Appendix E Outline Dimensional Drawing

## DIMENSIONS

For single acting actuator without regulator

[Unit: mm]

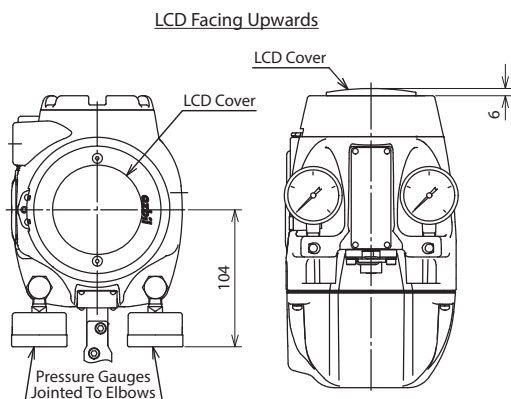
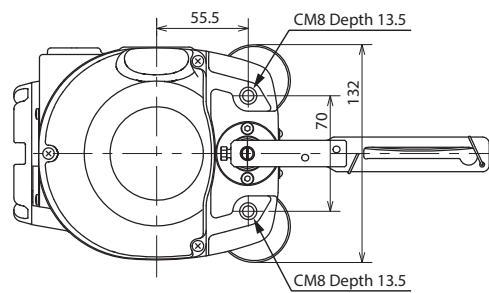
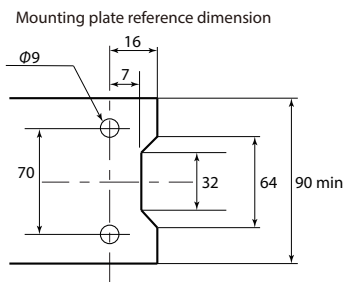
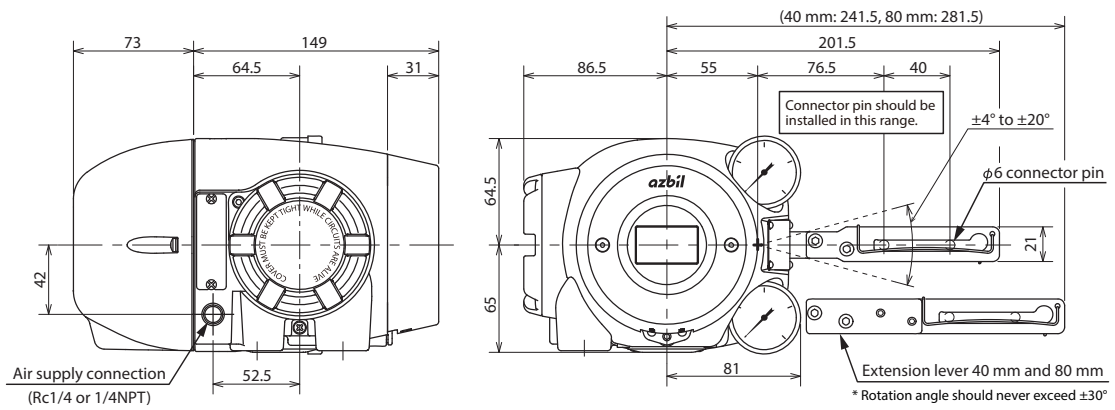
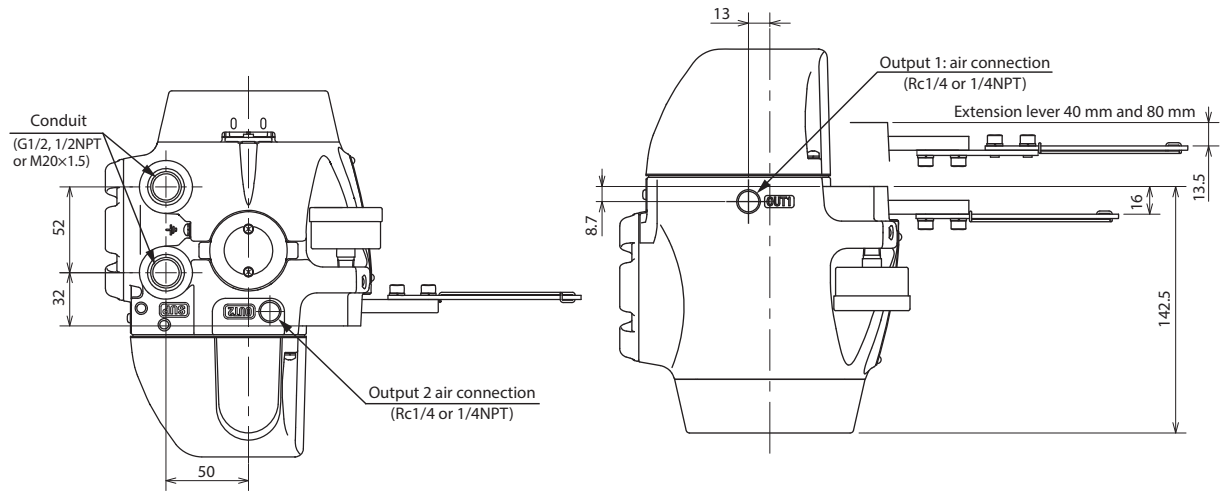

### Terminal

Screw size: M4

AVP701

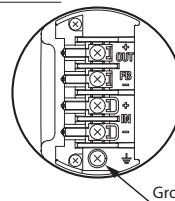

AVP702

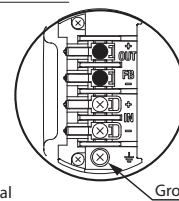

**For single acting actuator with RA1B regulator**

[Unit: mm]

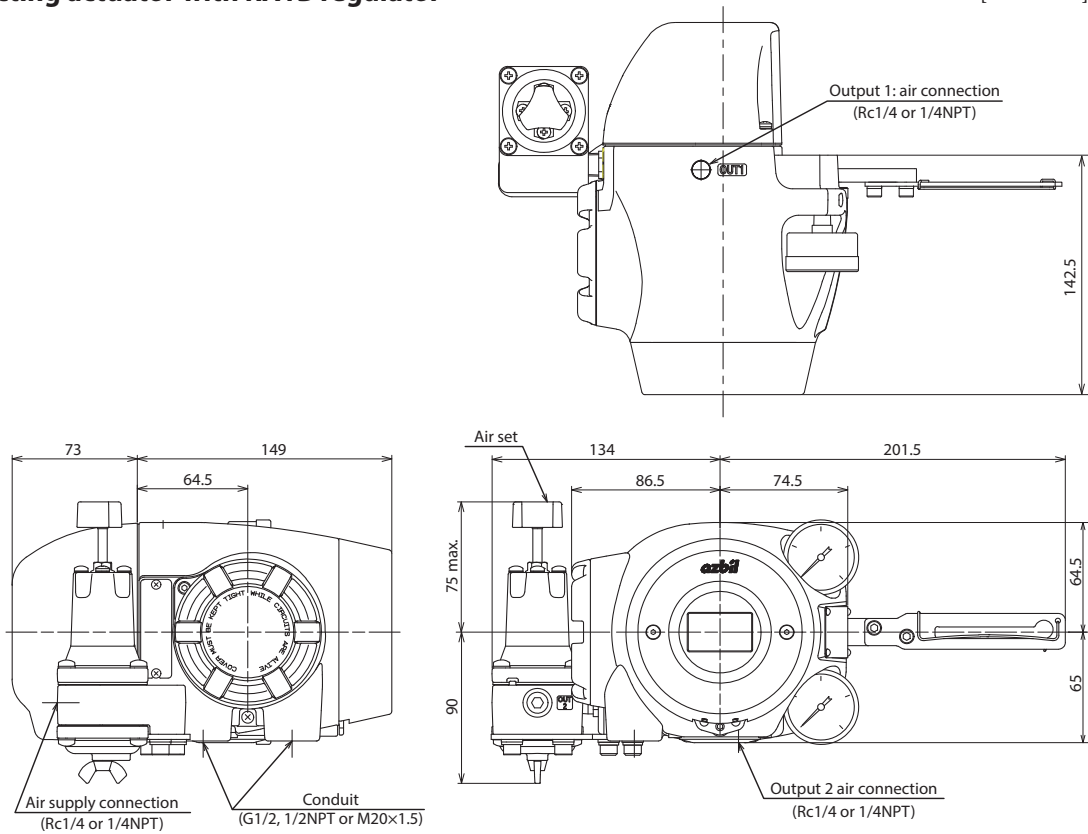

**For single acting actuator with KZ03 regulator**

[Unit: mm]

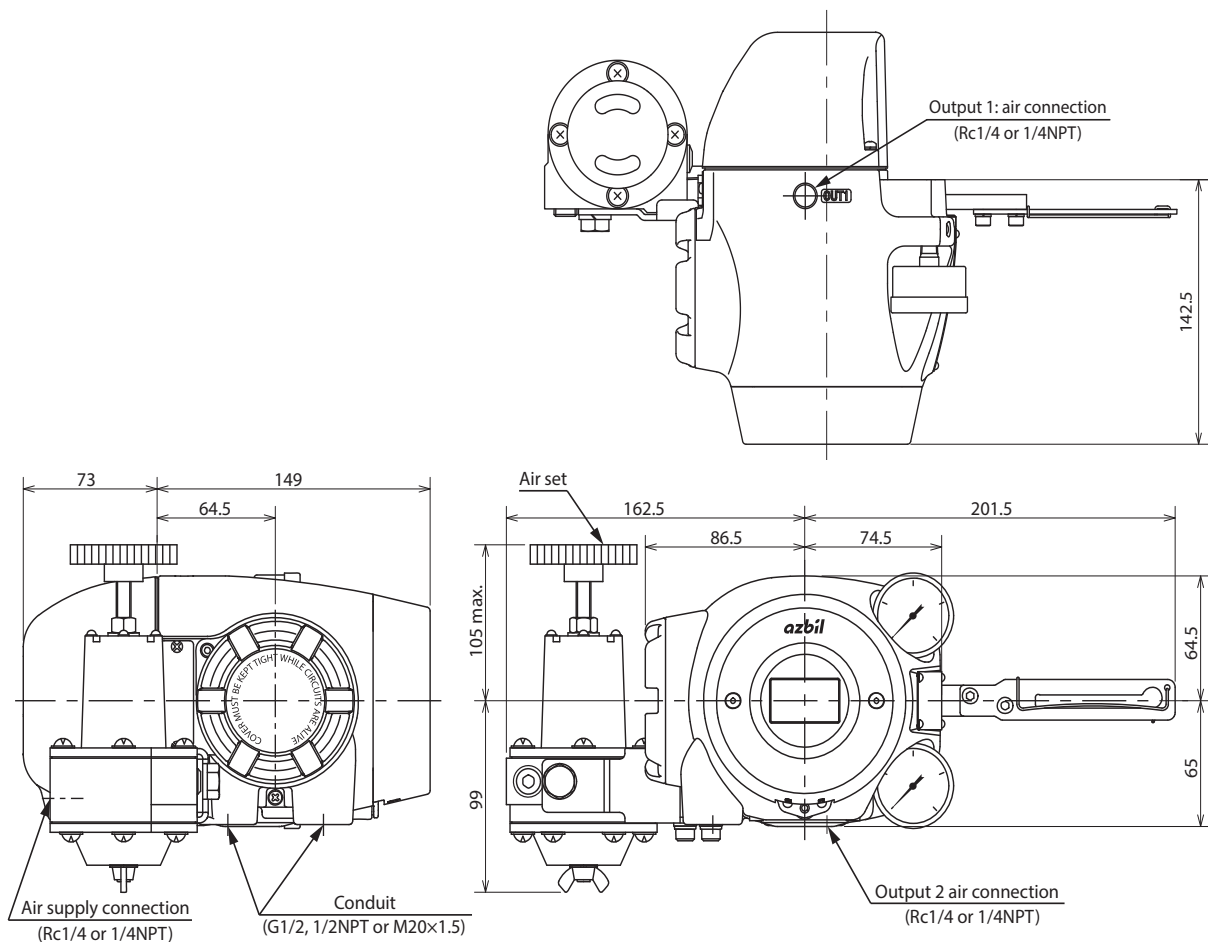

**For double acting actuator without regulator**

[Unit: mm]

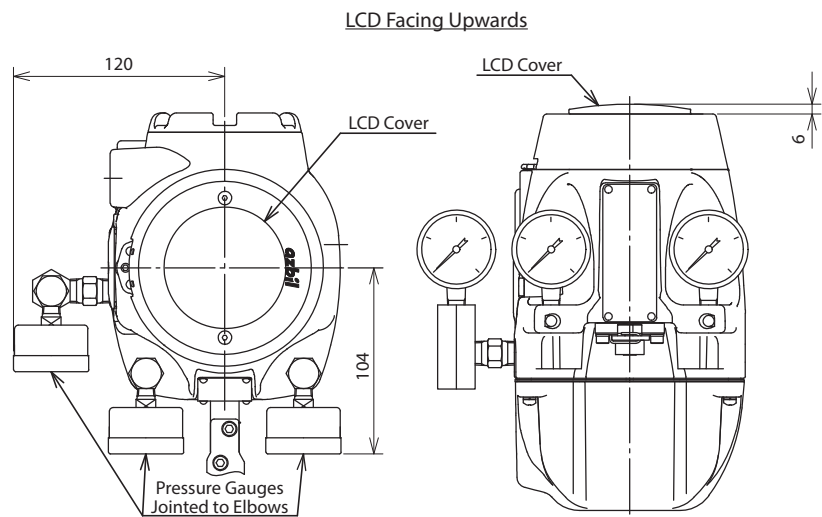
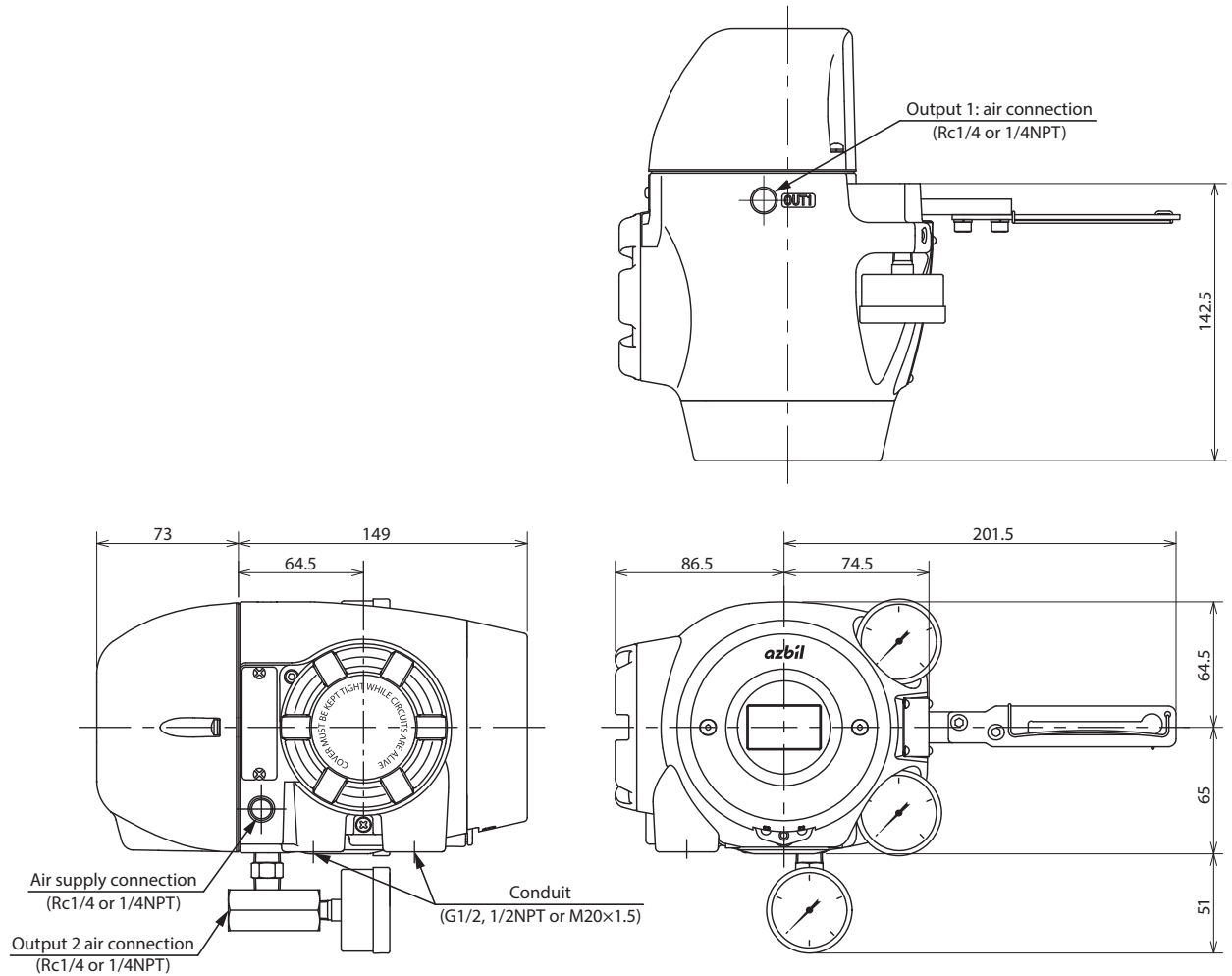

**For double acting actuator with RA1B regulator**

[Unit: mm]

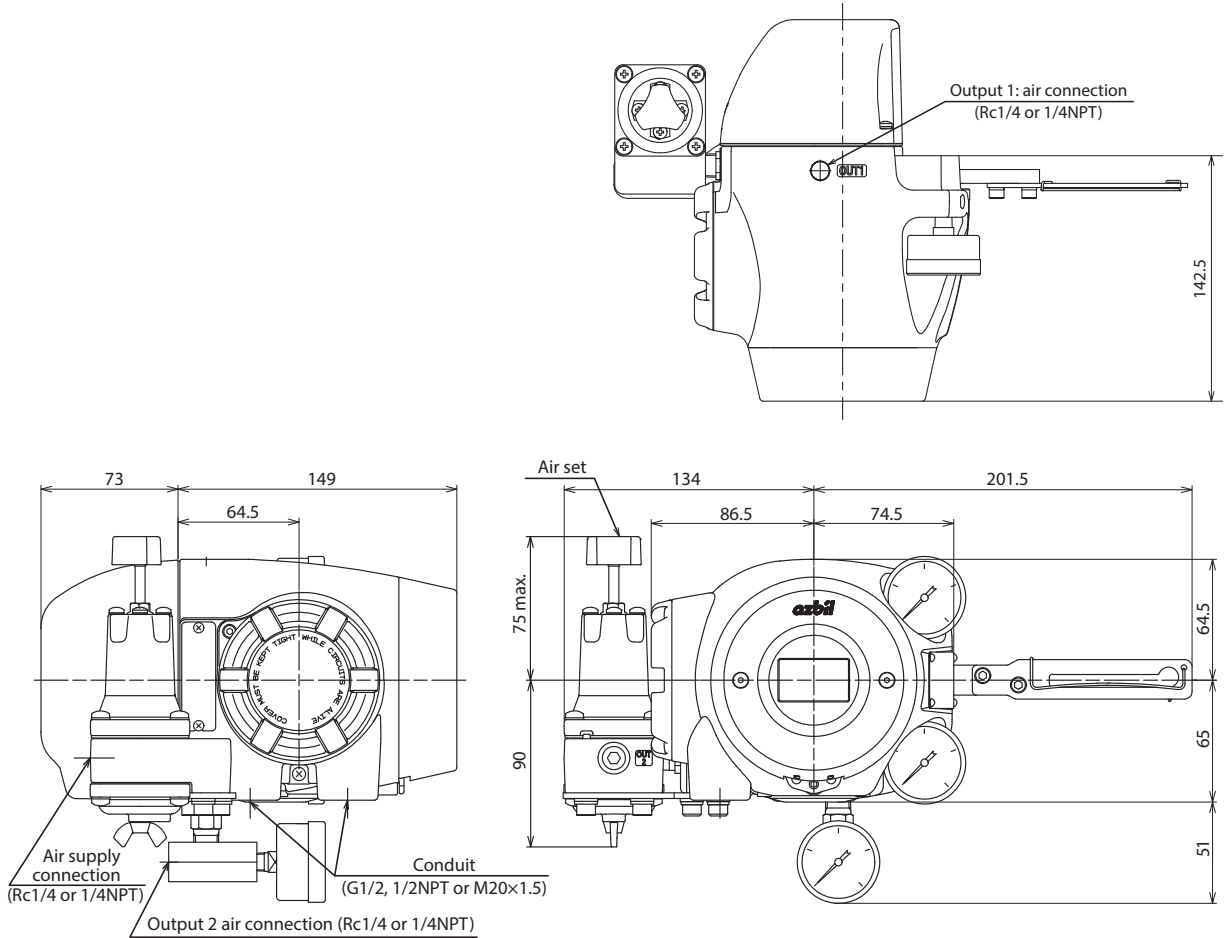

**For double acting actuator with KZ03 regulator**

[Unit: mm]

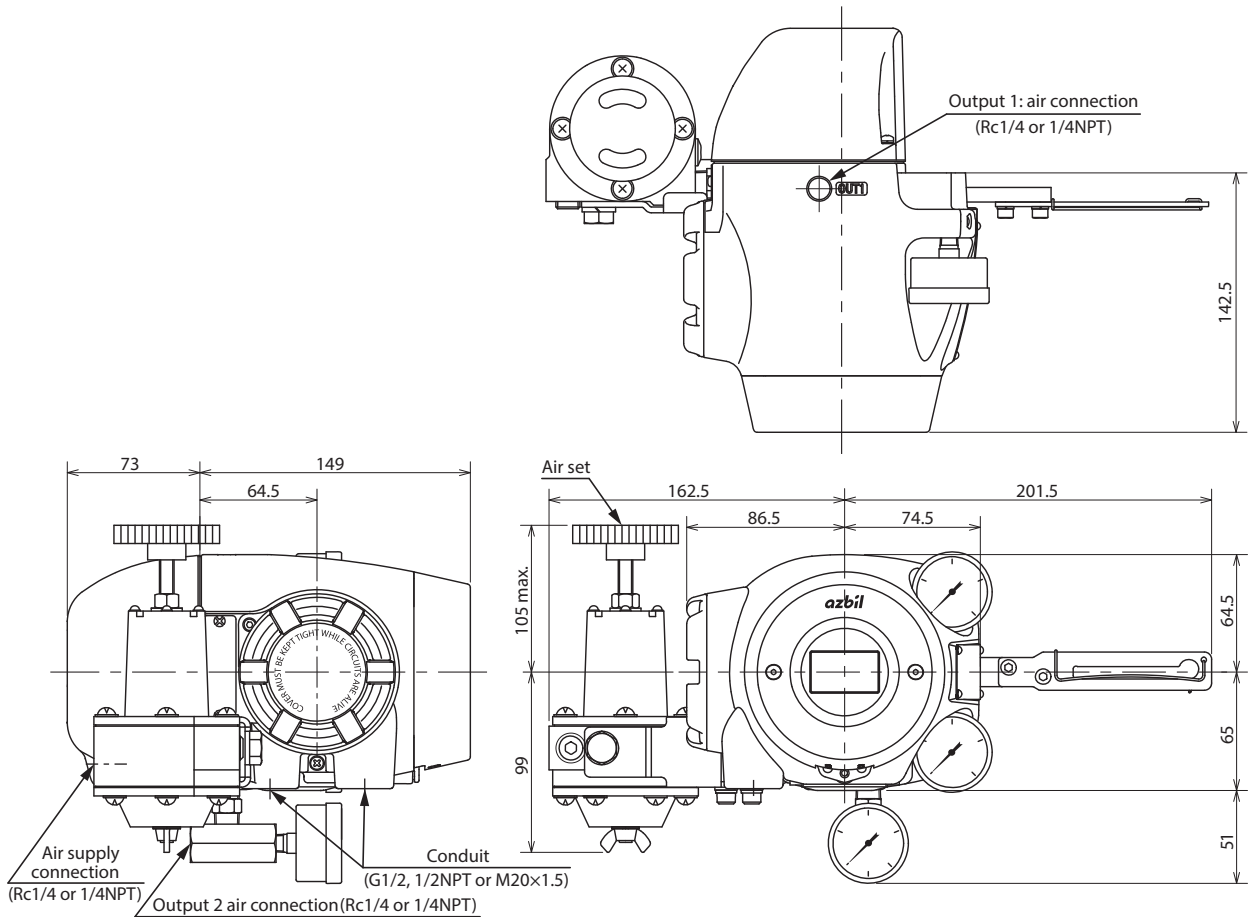

# Terms and Conditions

We would like to express our appreciation for your purchase and use of Azbil Corporation's products.

You are required to acknowledge and agree upon the following terms and conditions for your purchase of Azbil Corporation's products (system products, field instruments, control valves, and control products), unless otherwise stated in any separate document, including, without limitation, estimation sheets, written agreements, catalogs, specifications and instruction manuals.

## 1. Warranty period and warranty scope

### 1.1 Warranty period

Azbil Corporation's products shall be warranted for one (1) year from the date of your purchase of the said products or the delivery of the said products to a place designated by you.

### 1.2 Warranty scope

In the event that Azbil Corporation's product has any failure attributable to azbil during the aforementioned warranty period, Azbil Corporation shall, without charge, deliver a replacement for the said product to the place where you purchased, or repair the said product and deliver it to the aforementioned place. Notwithstanding the foregoing, any failure falling under one of the following shall not be covered under this warranty:

- (1) Failure caused by your improper use of azbil product (noncompliance with conditions, environment of use, precautions, etc. set forth in catalogs, specifications, instruction manuals, etc.);
- (2) Failure caused for other reasons than Azbil Corporation's product;
- (3) Failure caused by any modification or repair made by any person other than Azbil Corporation or Azbil Corporation's subcontractors;
- (4) Failure caused by your use of Azbil Corporation's product in a manner not conforming to the intended usage of that product;
- (5) Failure that the state-of-the-art at the time of Azbil Corporation's shipment did not allow Azbil Corporation to predict; or
- (6) Failure that arose from any reason not attributable to Azbil Corporation, including, without limitation, acts of God, disasters, and actions taken by a third party.

Please note that the term "warranty" as used herein refers to equipment-only-warranty, and Azbil Corporation shall not be liable for any damages, including direct, indirect, special, incidental or consequential damages in connection with or arising out of Azbil Corporation's products.

## 2. Ascertainment of suitability

You are required to ascertain the suitability of Azbil Corporation's product in case of your use of the same with your machinery, equipment, etc. (hereinafter referred to as "Equipment") on your own responsibility, taking the following matters into consideration:

- (1) Regulations and standards or laws that your Equipment is to comply with.
- (2) Examples of application described in any documents provided by Azbil Corporation are for your reference purpose only, and you are required to check the functions and safety of your Equipment prior to your use.
- (3) Measures to be taken to secure the required level of the reliability and safety of your Equipment in your use

Although azbil is constantly making efforts to improve the quality and reliability of Azbil Corporation's products, there exists a possibility that parts and machinery may break down. You are required to provide your Equipment with safety design such as fool-proof design,\*1 and fail-safe design\*2 (anti-flame propagation design, etc.), whereby preventing any occurrence of physical injuries, fires, significant damage, and so forth. Furthermore, fault avoidance,\*3 fault tolerance,\*4 or the like should be incorporated so that the said Equipment can satisfy the level of reliability and safety required for your use.

\*1. A design that is safe even if the user makes an error.

\*2. A design that is safe even if the device fails.

\*3. Avoidance of device failure by using highly reliable components, etc.

\*4. The use of redundancy.

## 3. Precautions and restrictions on application

### 3.1 Restrictions on application

Please follow the table below for use in nuclear power or radiation-related equipment.

	Nuclear power quality*5 required	Nuclear power quality*5 not required
Within a radiation controlled area*6	Cannot be used (except for limit switches for nuclear power*7)	Cannot be used (except for limit switches for nuclear power*7)
Outside a radiation controlled area*6	Cannot be used (except for limit switches for nuclear power*7)	Can be used

\*5. Nuclear power quality: compliance with JEAG 4121 required

\*6. Radiation controlled area: an area governed by the requirements of article 3 of "Rules on the Prevention of Harm from Ionizing Radiation," article 2 2 4 of "Regulations on Installation and Operation of Nuclear Reactors for Practical Power Generation," article 4 of "Determining the Quantity, etc., of Radiation-Emitting Isotopes," etc.

\*7. Limit switch for nuclear power: a limit switch designed, manufactured and sold according to IEEE 382 and JEAG 4121.

Any Azbil Corporation's products shall not be used for/with medical equipment.

The products are for industrial use. Do not allow general consumers to install or use any Azbil Corporation's product. However, azbil products can be incorporated into products used by general consumers. If you intend to use a product for that purpose, please contact one of our sales representatives.

### 3.2 Precautions on application

you are required to conduct a consultation with our sales representative and understand detail specifications, cautions for operation, and so forth by reference to catalogs, specifications, instruction manual, etc. in case that you intend to use azbil product for any purposes specified in (1) through (6) below. Moreover, you are required to provide your Equipment with fool-proof design, fail-safe design, anti-flame propagation design, fault avoidance, fault tolerance, and other kinds of protection/safety circuit design on your own responsibility to ensure reliability and safety, whereby preventing problems caused by failure or nonconformity.

- (1) For use under such conditions or in such environments as not stated in technical documents, including catalogs, specification, and instruction manuals
- (2) For use of specific purposes, such as:
  - \* Nuclear energy/radiation related facilities  
[When used outside a radiation controlled area and where nuclear power quality is not required]  
[When the limit switch for nuclear power is used]
  - \* Machinery or equipment for space/sea bottom
  - \* Transportation equipment  
[Railway, aircraft, vessels, vehicle equipment, etc.]
  - \* Antidisaster/crime-prevention equipment
  - \* Burning appliances
  - \* Electrothermal equipment
  - \* Amusement facilities
  - \* Facilities/applications associated directly with billing
- (3) Supply systems such as electricity/gas/water supply systems, large-scale communication systems, and traffic/air traffic control systems requiring high reliability
- (4) Facilities that are to comply with regulations of governmental/public agencies or specific industries
- (5) Machinery or equipment that may affect human lives, human bodies or properties
- (6) Other machinery or equipment equivalent to those set forth in items (1) to (5) above which require high reliability and safety

#### 4. Precautions against long-term use

Use of Azbil Corporation's products, including switches, which contain electronic components, over a prolonged period may degrade insulation or increase contact-resistance and may result in heat generation or any other similar problem causing such product or switch to develop safety hazards such as smoking, ignition, and electrification. Although acceleration of the above situation varies depending on the conditions or environment of use of the products, you are required not to use any Azbil Corporation's products for a period exceeding ten (10) years unless otherwise stated in specifications or instruction manuals.

#### 5. Recommendation for renewal

Mechanical components, such as relays and switches, used for Azbil Corporation's products will reach the end of their life due to wear by repetitious open/close operations.

In addition, electronic components such as electrolytic capacitors will reach the end of their life due to aged deterioration based on the conditions or environment in which such electronic components are used. Although acceleration of the above situation varies depending on the conditions or environment of use, the number of open/close operations of relays, etc. as prescribed in specifications or instruction manuals, or depending on the design margin of your machine or equipment, you are required to renew any Azbil Corporation's products every 5 to 10 years unless otherwise specified in specifications or instruction manuals. System products, field instruments (sensors such as pressure/flow/level sensors, regulating valves, etc.) will reach the end of their life due to aged deterioration of parts. For those parts that will reach the end of their life due to aged deterioration, recommended replacement cycles are prescribed. You are required to replace parts based on such recommended replacement cycles.

#### 6. Other precautions

Prior to your use of Azbil Corporation's products, you are required to understand and comply with specifications (e.g., conditions and environment of use), precautions, warnings/cautions/notices as set forth in the technical documents prepared for individual Azbil Corporation's products, such as catalogs, specifications, and instruction manuals to ensure the quality, reliability, and safety of those products.

#### 7. Changes to specifications

Please note that the descriptions contained in any documents provided by azbil are subject to change without notice for improvement or for any other reason. For inquires or information on specifications as you may need to check, please contact our branch offices or sales offices, or your local sales agents.

#### 8. Discontinuance of the supply of products/parts

Please note that the production of any Azbil Corporation's product may be discontinued without notice. After manufacturing is discontinued, we may not be able to provide replacement products even within the warranty period.

For repairable products, we will, in principle, undertake repairs for five (5) years after the discontinuance of those products. In some cases, however, we cannot undertake such repairs for reasons, such as the absence of repair parts. For system products, field instruments, we may not be able to undertake parts replacement for similar reasons.

#### 9. Scope of services

Prices of Azbil Corporation's products do not include any charges for services such as engineer dispatch service. Accordingly, a separate fee will be charged in any of the following cases:

- (1) Installation, adjustment, guidance, and attendance at a test run
- (2) Maintenance, inspection, adjustment, and repair
- (3) Technical guidance and technical education
- (4) Special test or special inspection of a product under the conditions specified by you

Please note that we cannot provide any services as set forth above in a nuclear energy controlled area (radiation controlled area) or at a place where the level of exposure to radiation is equivalent to that in a nuclear energy controlled area.

---

Document Number: CM2-AVP702-2001  
Document Name: Smart Valve Positioner  
700 Series with HART Communication Protocol  
Model AVP701/702  
User's Manual

---

Date: 1st edition: July 2014  
13th edition: Feb. 2024  
Issued/Edited by: Azbil Corporation

---

Azbil Corporation