

# Dynamic Self-Checking Burner Controller

## Model AUR455

### Overview

The AUR455 dynamic self-checking burner controller can be used for both continuous operation and batch operation. It is a combustion safety controller that follows the correct ignition sequence to automatically and safely ignite gas burners and oil burners. This device can be used in combination with the AUD300C advanced ultraviolet flame detector, the AUD500C explosion-proof advanced ultraviolet flame detector, or a flame rod. The AUR455 drives the shutter that is built into the AUD300C/AUD500C to continuously check both its own flame detection circuit and the ultraviolet detector in order to provide flame detection for continuous burner operation. Also, when used with a flame rod, the AUR455 continuously checks its own built-in flame detection circuit to provide flame detection for continuous burner operation.

The front connector provides a communication function and event output that are convenient for maintenance and troubleshooting. Note particularly that the PC loader can read out various kinds of data recorded in the AUR455 using the RS-485 communications protocol, including the flame voltage, ignition delay time, combustion count, combustion time of any sequence, the recorded state for approximately 10 seconds before an alarm is activated (playback function), and alarm history containing up to 16 records on operating status at the time of alarm activation, and alarm details. This data is useful for troubleshooting and preventive maintenance. Also, when the combustion time reaches 25,000 hours and the ultraviolet detector needs to be replaced, the event output turns ON to ensure timely replacement. Additionally, on the front face of the unit, a 7-segment display shows the flame voltage and the current operating status. When an alarm is activated, the display indicates an operating status and an alarm code so that the details can be checked easily.

### Features

- **Safety standard certification**  
CE/FM/UL/KC
- **Selectable ignition sequence**  
The pilot ignition time can be selected from 4 s or 8 s. The ignition method can be selected from intermittent pilot and interrupted pilot.
- **Ease of instrumentation and handling**  
Designed for compactness, so requires little installation space. Wires connect to the sub-base, so the unit is easy to install/remove. Flame monitor and alarm output contacts are available as independent non-voltage contacts. There is a terminal for external reset input. This device can be reset from the operation panel.
- **Multifunction display**  
The 7-segment display is useful for maintenance and troubleshooting, helping to identify the progress of operations, alarm codes, and event codes.  
In addition, flame detection and alarm activation can be checked visually with LED indicators.



### Note:

The use of this device is strictly restricted by safety guidelines and other standards. For safety, use this device only with compatible equipment.

### ■ Precautions for instrumentation

Facilities that use combustion safety equipment must be designed in compliance with relevant laws, standards, safety guidelines, and the like.

- **Main safety policies in Japan**  
Technical Policy on Safety Standards for Combustion Equipment in Industrial Furnaces, by Ministry of Health, Labor and Welfare
- Combustion Equipment in Compliance with the Safety Principles for Industrial Incinerators - JIS B 8415
- Index of Safety Technology of Industrial Gas Combustion Equipment, by Japan Gas Association
- Index of Safety Technology of Gas Boiler Combustion Facilities, by Japan Gas Association
- **U.S.A. NFPA 86**  
Combustion Safety Guidelines, by National Fire Protection Association
- **Europe EN 746 (Industrial Thermoprocessing Equipment) 93/68/EEC (CE Marking Directive) amending Appliances Burning Gaseous Fuels**
- For use of this product abroad, create a design with reference to the laws and standards of the relevant country.

### ● Important points for ensuring safety

1. Connect loads directly to this device.
2. Design the interlock so that it can directly cut off power to the load.
3. Be sure to use a safe startup circuit upon startup.
4. Do not add a bypass circuit that allows manual operation of any load.
5. Both the main valve and pilot valve must have redundant shutoff.

### ● Precautions for system design

This device does not have a purge function. It must be provided externally.

## Specifications

Item	Description				
Application	Gas- or oil-burning combustion equipment				
Compatible flame detector	Model AUD300C/500C ultraviolet flame detector, flame rod				
Sequence	Sequence timing	Ignition trial	Pilot stabilization (Hi solenoid valve ignition standby)*1	Main trial (Hi solenoid valve ignition)*1	
		Selectable by model No.	7.0 ±1.0 s	Selectable by model No.	
	Flame failure response	AUD300C/500C ultraviolet flame detector		Flame rod	
		2 s or 4 s max. (when flame voltage is 3 V)		4 s max. (when flame voltage is 2 V)	
	Reset timing	1 s or longer (main unit reset switch or contact reset input*3)			
	Alarm detection timing	False flame error		Interlock error	
		5 s		1 s or shorter	
	Lockout	Lockout requiring manual reset			
	Operation at ignition failure	Lockout			
Operation at flame failure	Lockout				
Electrical specifications	Rated power	100/120/200/230 V AC, 50/60 Hz			
	Allowable power	85 to 110 % of rated power			
	Power consumption	15 W or less (AUR455C) 10 W or less (AUR455B)			
	Dielectric strength	1500 V AC for 1 min or 1800 V AC for 1 s Between each terminal and ground (the DIN rail clamp), except for flame detector connection terminals (terminals 14–15 and 16–17)			
	Insulation resistance	50 MΩ min. with a 500 V DC megger Between each terminal and ground (the DIN rail clamp), except for flame detector connection terminals (terminals 14–15 and 16–17)			
	Contact rating	Ignition transformer	Pilot valve (Lo solenoid valve)*1	Main valve (Hi solenoid valve)*1	Alarm
		300 VA	200 VA	200 VA	75 VA
	Event output*2	30 mA max.			
	Flame detection level	AUD300C/500C ultraviolet flame detector		Flame rod	
	Flame detection	1.5–4.5 V DC		1.5–4.5 V DC	
	Flame out detection	0.0–0.6 V DC		0.0–0.2 V DC	
	Flame voltage output	Recommended flame voltage: Stable 2.0 V DC min. Flame voltage output range: 0.0–5.0 V DC		Recommended flame voltage: Stable 2.0 V DC min. Flame voltage output range: 0.0–4.5 V DC	
	Input	Start, interlock, contact reset Each input is a non-voltage contact input, with allowable contact resistance up to 500 Ω			
Service life	7 years or 100,000 relay operations (at 25 °C, room temperature, rated power)				
Operating conditions	Ambient temperature	Mounting of single unit: –20 to +60 °C Gang mounting: –20 to +45 °C			
	Ambient humidity	10–90 % RH (without condensation)			
	Vibration	0–3.2 m/s <sup>2</sup> (10–150 Hz, 1 octave/minute, 10 cycles, in each of XYZ directions)			
	Shock	0–9.8 m/s <sup>2</sup>			
	Mounting angle	Reference plane ±10°			
	Dust	0.3 mg/m <sup>3</sup> max.			

Item		Description
General specifications	Protection rating	IP40: if sideboards (81447515-001) are attached to the sub-base (model BC-R05) IP10, with sub-base (model BC-R05) only
	Overvoltage category	II
	Pollution degree	PD2
	Automatic action	Type 2.A.V
	Software	Class C
	Case color	Black
	Case material	Denatured PPE resin (UL94-V0 PT1 materials group IIIa)
	Structure	Sub-base and main unit
	Mounting orientation	Vertical or horizontal Note: For horizontal mounting, the 7-segment display must face upward. (DIN rail mounting or direct mounting through base screw holes)
	Standards compliance	JIS C 9730-2-5: 2010*4 <u>Certifications</u> CE Marking*5 <ul style="list-style-type: none"> <li>• Gas Appliances Regulation (2016/426/EU) based on EN 298: 2012</li> <li>• Low Voltage Directive (2014/35/EU) based on EN 60730-2-5: 2015</li> <li>• Electromagnetic Compatibility Directive (2014/30/EU) based on EN 61000-6-2: 2019, EN 61000-6-4: 2019</li> <li>• RoHs Directive (2011/65/EU) based on EN IEC63000: 2018</li> </ul> KC Marking FM Approved (FM 7610)*5 UL Listed (UL 60730-2-5)(certified models: AUR455_ _ _ _ 1_ _ , AUR455_ _ _ _ 3_ _ )*5
Dimensions	W95 × H105 × D110 mm incl. sub-base	
Weight	Approximately 600 g (incl. sub-base)	
Wiring types and max. wiring length	<ul style="list-style-type: none"> <li>• Start, interlock Copper 600 V PVC-insulated cable (IEC 60227-3), 1.25 mm<sup>2</sup> Recommended length: 20 m max. Maximum length: 100 m</li> <li>• Contact reset Copper 600 V PVC-insulated cable (IEC 60227-3), 1.25 mm<sup>2</sup>, maximum length: 10 m</li> <li>• AUD300C/500C (F, G, S1, S2) Copper 600 V PVC-insulated cable (IEC 60227-3), 1.25 mm<sup>2</sup>, maximum length: 200 m</li> <li>• Flame rod (F, G) RG-11U (JAN standard: US DoD-compliant specification) Or equivalent 5C2V, 7C2V (JIS standard) Recommended length: 20 m max. Maximum length: 30 m</li> <li>• RS-485 communications (3-wire system) 0.2–1.5 mm<sup>2</sup> Shielded twisted-pair cable (recommended) Maximum length: 500 m</li> <li>• Flame voltage output signal 600 V PVC-insulated cable (IEC 60227-3), 0.75 mm<sup>2</sup> min., maximum length: 10 m</li> <li>• Event output JIS C 3306: 0.75 mm<sup>2</sup> min.</li> </ul>	

\*1. Item in parentheses ( ) is for the case of direct ignition.

\*2. If an inductive load is connected, connect a protective circuit such as an RC snubber to the load in parallel.

\*3. For details on the contact reset input specification, see the user's manual for the AUR455 (document No. CP-SP-1439E).

\*4. There is no certifying body for JIS standards. By obtaining third-party certification for the equivalent European (CE) or North American (UL/FM, etc.) standards, the product can be considered to be compliant with JIS C 9730-2-5:2010.

\*5. The AUR455C is certified if it is used in combination with the AUD300C.

## Model selection

### ● Interrupted pilot models

Ex.: AUR455B423100

Basic model No.	Flame detector	Ignition trial	Main trial	Flame failure re-sponse	Power	Pilot sequence	Add'l func.	Description	Remarks
AUR455	B	C						Flame rod	
								Ultraviolet flame detector	
		4						4.5 ±0.5 s	
		8						9 ±1.0 s	
			2					7.0 ±1.0 s	
			3					4.5 ±0.5 s	JIS response time
				2				2 s max.	AUR455C only
				3				4 s max.	
					1			100 V AC	
					2			200 V AC	
					3			120 V AC	
					5			230 V AC	
						0		Interrupted pilot	*
						0		Without inspection data	
						D		With inspection data	

\* If the ignition method is intermittent pilot, select a direct ignition model.

### ● Direct ignition models

Ex.: AUR455B433110

Basic model No.	Flame detector	Ignition trial	(Not used)	Flame failure re-sponse	Power	Pilot sequence	Add'l func.	Description	Remarks
AUR455	B	C						Flame rod	
								Ultraviolet flame detector	
		4						4.5 ±0.5 s	
		8						9 ±1.0 s	
			3					Always "3"	
				2				2 s max.	AUR455C only
				3				4 s max.	
					1			100 V AC	
					2			200 V AC	
					3			120 V AC	
					5			230 V AC	
						1		Direct ignition, no shutoff valve closure check	
						0		Without inspection data	
						D		With inspection data	

## Related devices

### ● Compatible ultraviolet flame detector (sold separately)

Model No.	Name
AUD500C11_ _ _ _	Explosion-proof advanced ultraviolet flame detector
AUD300C100_ _	Advanced ultraviolet flame detector
AUD300C110_ _	

\_ : 0 = standard product,

D = with inspection report (with data),

T = tropicalization,

Y = traceability certificate, DT = tropicalization + inspection report,

YT = traceability certificate + tropicalization

### ● Optional parts (sold separately)

Model No.	Name
BC-R05A100	Dedicated sub-base (a requirement for AUR455)
81447514-001	Connector for front wiring Weidmüller BL3.5/11F Compatible wire: 0.2–1.5 mm <sup>2</sup> (28–14 AWG)
81447514-002	Connector for front wiring (for right side wiring) Weidmüller BL3.5/11/270F Compatible wire: 0.2–1.5 mm <sup>2</sup> (28–14 AWG)
81447515-001	Side boards (2)
SLP-A55J91	Smart Loader Package (no cable)
81441177-001	USB loader cable
FSP136A100	Analog flame meter
81447519-001	Jack cover (1)
83968019-001	Surge absorber

## Dimensions

Unit: mm

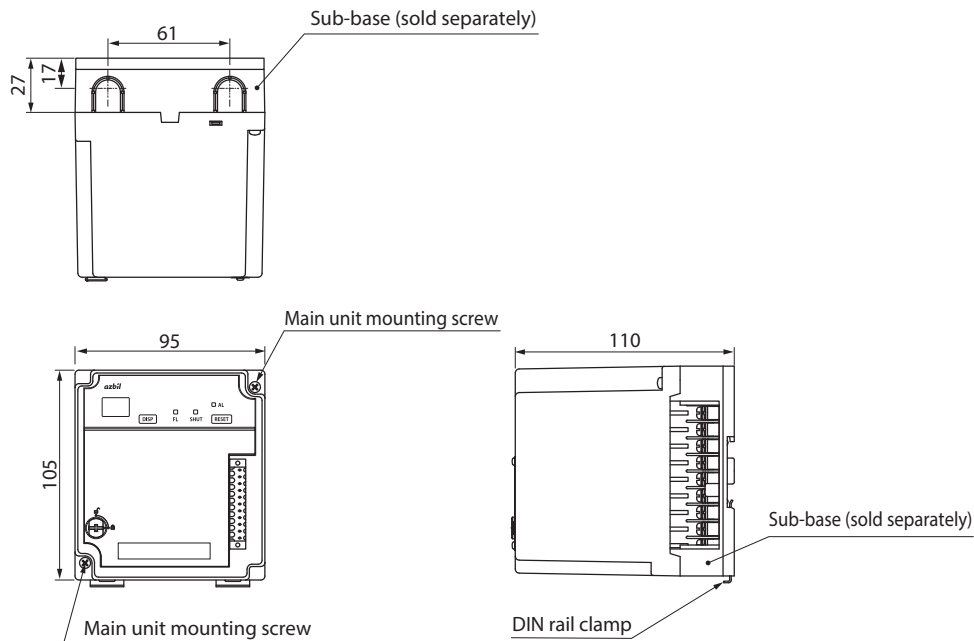

## Part name

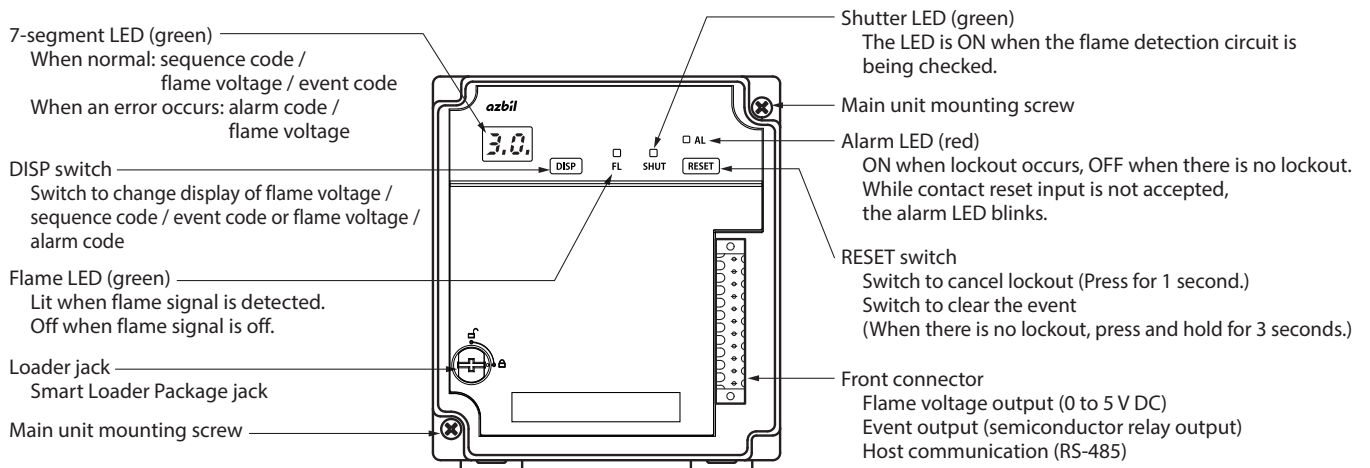

## 7-segment display

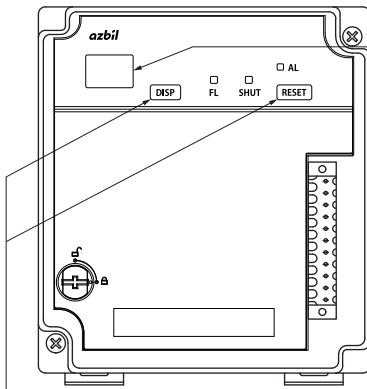

DISP switch:  
Switches display between  
sequence code and flame voltage.

RESET switch:  
Resets the alarm (for lockout).

### ● Sequence code

In normal operation, the sequence code corresponding to each operating status is displayed. The table below shows the code and the operating status.

#### Interrupted pilot models

Display	Status
P1	Start check
P4	Ignition trial
P5	Pilot only
P6	Main trial
P8	Run
--	Controlled shutdown

#### Direct ignition models

Display	Status
P1	Start check
P4	Ignition trial
P5	Hi solenoid valve ignition standby
P6	Hi solenoid valve ignition
P8	Run
--	Controlled shutdown

#### Examples of alarm and sequence code display

- Alarm code: E0–E7

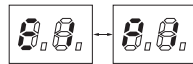

The item displayed changes every 0.8 s.

- Alarm code: E9 + subcode (2 digits)

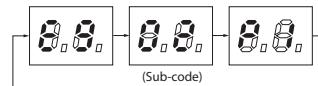

The item displayed changes every 0.8 s.

### ● Alarm code

If lockout occurs, an alarm code is displayed automatically.

The alarm code and the code for the sequence step where the lockout occurred are displayed alternately.

Display	Name	Description
E0	Interlock	Interlock error
E1	False flame	Flame signal was detected for 5 s during start check.
E2	UV flame detector error	Self-discharge of the ultraviolet flame detector occurred during combustion control.
E6	Ignition failure	Ignition could not be detected during the ignition trial.
E7	Flame failure	The flame signal was lost at a point in the sequence after the ignition trial.
E9 + sub-code (2 digits)*	Device error	Abnormal voltage detected in output from the ignition transformer, pilot valve, or main valve, etc.

\* For details, refer to the user's manual for the AUR455 (document No. CP-SP-1439E).

### ● Event code

If an event specified in advance occurs, the event output turns on.

Display	Event name	Operation
R1*	UV flame detector check (combustion time)	Turns on if the combustion time exceeds the value set for "UV flame detector check (combustion time)."
R2	Product service life check (total operating time)	Turns on if the total operating time exceeds the value set for "Product service life check (total operating time)."
R3	Product service life check (total combustion count)	Turns on if the total combustion count exceeds the value set for "Product service life check (total combustion count)."

\* This can also be used as a maintenance event for the flame detector or flame rod.

## Wiring and Internal Block Diagrams

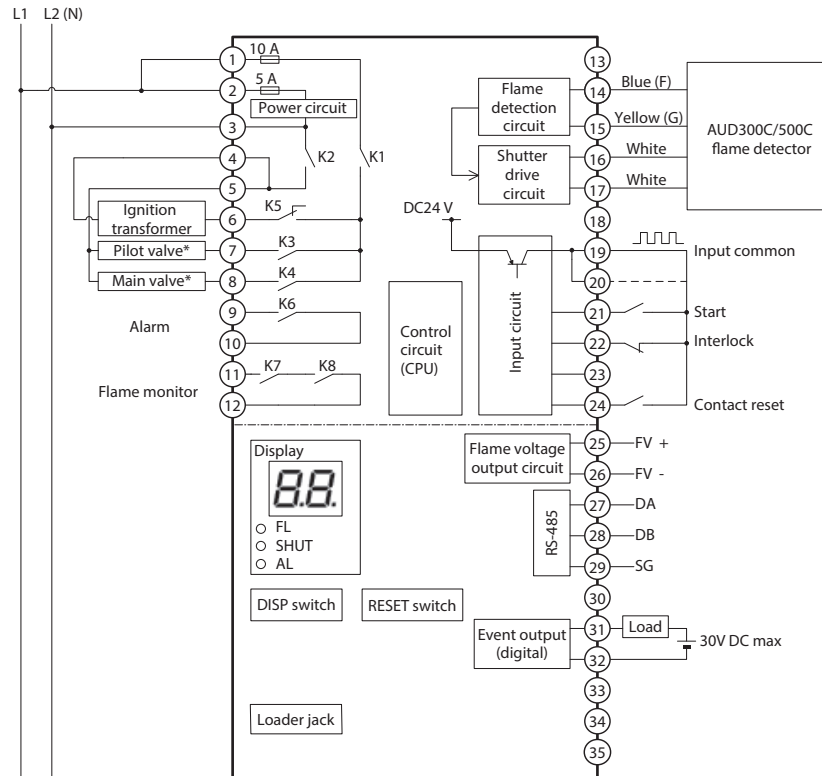

\* The names used for loads above are for interrupted pilot systems only. In the case of direct ignition, the pilot valve is the Lo solenoid valve, and the main valve is the Hi solenoid valve.

Note • After mounting the connector for front wiring, secure it in place with the mounting screw on the side of the connector.

• The contact reset input (terminal 24) must be used by a single AUR device only. Do not share the terminal with other AUR devices.

• Do not share the output common (terminals 4, 5) and the input common (terminals 19, 20) with other AUR devices.

## Terminals and characteristics

### ● Terminal layout (sub-base)

No.	Code	Function	No.	Code	Function
1	-	Load power	13	-	Not used
2	AC-H	Power (H)	14	F	Flame detector (F)
3	AC-G	Power (G)	15	G	Flame detector (G)
4	COM-G1	Output common 1	16	S1	Shutter output 1 (AUR455C only)
5	COM-G2	Output common 2	17	S2	Shutter output 2 (AUR455C only)
6	IG	Ignition transformer	18	-	Not used
7	PV	Pilot valve or Lo solenoid valve	19	COM1	Input common 1
8	MV	Main valve or Hi solenoid valve	20	COM2	Input common 2
9	AL-NO	Alarm output	21	START	Start input
10	AL-COM	Alarm output	22	IL	Interlock input
11	FL-NO	Flame monitor output	23	-	Not used
12	FL-COM	Flame monitor output	24	RESET	Contact reset input

### ● Terminal layout (front connector terminals)

No.	Code	Function	No.	Code	Function
25	FV+	Flame voltage output (+)	31	EV-COM	Event output
26	FV-	Flame voltage output (-)	32	EV-NO	Event output
27	DA	RS-485 (DA)	33	-	Not used
28	DB	RS-485 (DB)	34	-	Not used
29	SG	RS-485 (SG)	35	-	Not used
30	-	Not used			

Please read "Terms and Conditions" from the following URL  
before ordering and use.  
<https://www.azbil.com/products/factory/order.html>

*Specifications are subject to change without notice.*

**azbil**

**Azbil Corporation**  
Advanced Automation Company

1-12-2 Kawana, Fujisawa  
Kanagawa 251-8522 Japan  
URL: <https://www.azbil.com/>

1st edition: Jun. 2021  
3rd edition: Jun. 2023

*No part of this publication may be reproduced or duplicated  
without the prior written permission of Azbil Corporation.*