

**azbil**

**FloWing  
Eccentric Rotary type  
Control Valves**

**Model: VFR (6-inch or more)**

**User's Manual**

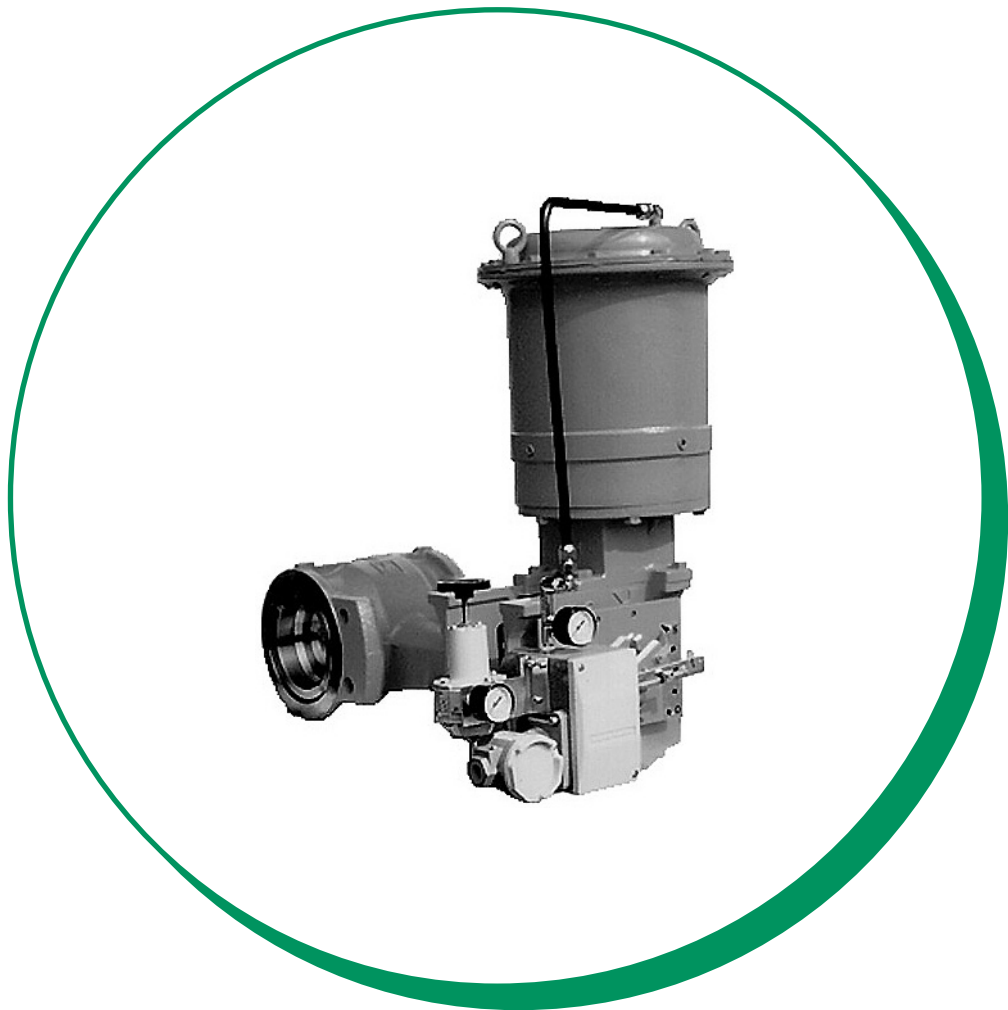

Azbil Corporation

OM2-8130-0200  
7th edition

# Copyright, Notices and Trademarks

---

**© 2012-2023 Azbil Corporation All Rights Reserved.**

While this information is presented in good faith and believed to be accurate, Azbil Corporation disclaims the implied warranties of merchantability and fitness for a particular purpose and makes no express warranties except as may be stated in its written agreement with and for its customer.

In no event shall Azbil Corporation be liable to anyone for any indirect, special or consequential damages. This information and specifications in this document are subject to change without notice.

# Table of Contents

---

---

## **Chapter 1 :Installation**

<b>1-1 : Confirming the specifications .....</b>	<b>1-1</b>
Compliance with Regulations.....	1-1
Requirements for workers (installation, operation, maintenance).....	1-1
<b>1-2 : Installation on piping.....</b>	<b>1-2</b>
<b>1-3 : Inspecting and maintaining the installed valve .....</b>	<b>1-3</b>

## **Chapter 2 :Valve Body**

<b>2-1 : Description .....</b>	<b>2-1</b>
<b>2-2 : Disassembly.....</b>	<b>2-3</b>
<b>2-3 : Assembly .....</b>	<b>2-4</b>

## **Chapter 3 :Actuator**

<b>3-1 : Description .....</b>	<b>3-1</b>
<b>3-2 : Adjusting the actuator.....</b>	<b>3-2</b>
<b>3-3 : Removing actuator from valve body.....</b>	<b>3-3</b>
<b>3-4 : Disassembly of actuator .....</b>	<b>3-4</b>
<b>3-5 : Assembly of actuator .....</b>	<b>3-6</b>
<b>3-6 : Mounting actuator on valve body .....</b>	<b>3-7</b>
<b>3-7 : Manual device (Handwheel).....</b>	<b>3-8</b>
3-7-1 : Setting automatic operation .....	3-8
3-7-2 : Setting manual control .....	3-9
3-7-3 : Setting the limit stopper.....	3-9

# Table of Contents

---

---

## **Chapter 4 :Valve Positioner**

<b>4-1 : Smart Valve Positioner (SVP)</b> .....	<b>4-1</b>
4-1-1 : Description .....	4-1
4-1-2 : Removing and installing the positioner .....	4-1
Removal .....	4-1
Installation .....	4-2
4-1-3 : Adjusting the positioner .....	4-2
4-1-4 : Maintaining the positioner .....	4-2
4-1-5 : Troubleshooting .....	4-2
<b>4-2 : Pneumatic valve positioner (model VFR)</b> .....	<b>4-3</b>
4-2-1 : Description .....	4-3
4-2-2 : Operating principle .....	4-4
4-2-3 : Bypass cock .....	4-5
Function of bypass cock .....	4-5
Installing the bypass cock .....	4-5
4-2-4 : Selecting cam characteristics .....	4-6
Cam characteristics .....	4-6
Using the equal-percent cam .....	4-6
Selecting a cam .....	4-6
4-2-5 : Removing and installing the positioner .....	4-7
Removal .....	4-7
Installation .....	4-7
4-2-6 : Adjusting the positioner .....	4-10
4-2-7 : Maintaining the positioner .....	4-11
Operating precautions .....	4-11
Troubleshooting .....	4-11
Cleaning the restriction .....	4-11
4-2-8 : Troubleshooting .....	4-13

## **Chapter 5 :Changing the mounting attitude of actuator and type of valve action**

<b>5-1 : Changing the mounting attitude of actuator</b> .....	<b>5-1</b>
<b>5-2 : Changing the valve action</b> .....	<b>5-1</b>

## General

The model VFR control valve consists of three main sections, namely, a valve body, a pneumatic actuator, and a valve positioner.

The valve body is of an eccentric rotary type, which features large valve capacity and high operation stability. It is possible to use this valve for slurry service.

The actuator is a pneumatic and spring type diaphragm motor. The actuator stem rotates the clamp. The rotational force of the clamp is transmitted to the valve stem as torque, and the valve plug is securely held in a position corresponding to the pneumatic signal applied. The actuator has a handwheel for manual control. The handwheel can be used also as a limiting stopper.

The positioner is a single-action positioner with a pneumatic force balance type servo mechanism. The cam directly mounted on the valve stem feeds-back the valve position information to ensure that the valve plug is accurately fixed in the position that corresponds to the applied pneumatic signal.

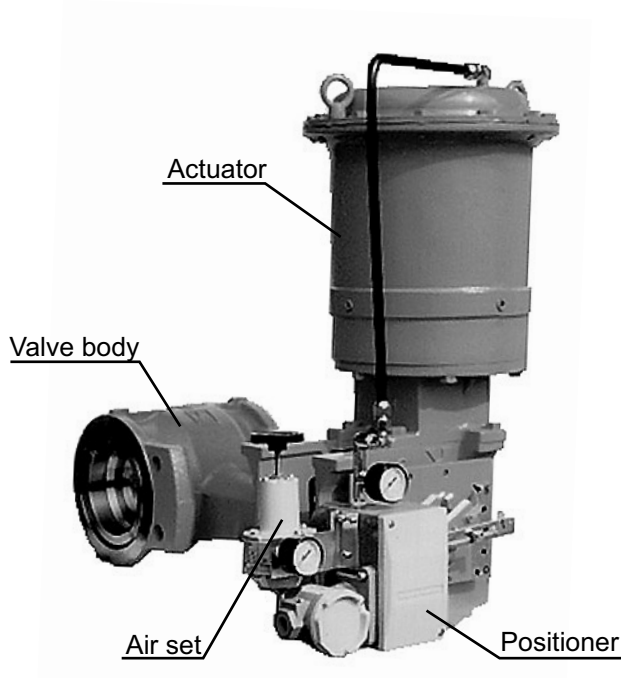

*Composition of model VFR*



# Chapter 1 : Installation

## 1-1 : Confirming the specifications

Prior to installing the valve, check that the model number, size, rating, materials and other specifications indicated on the nameplate attached on the actuator conform with those which were ordered.

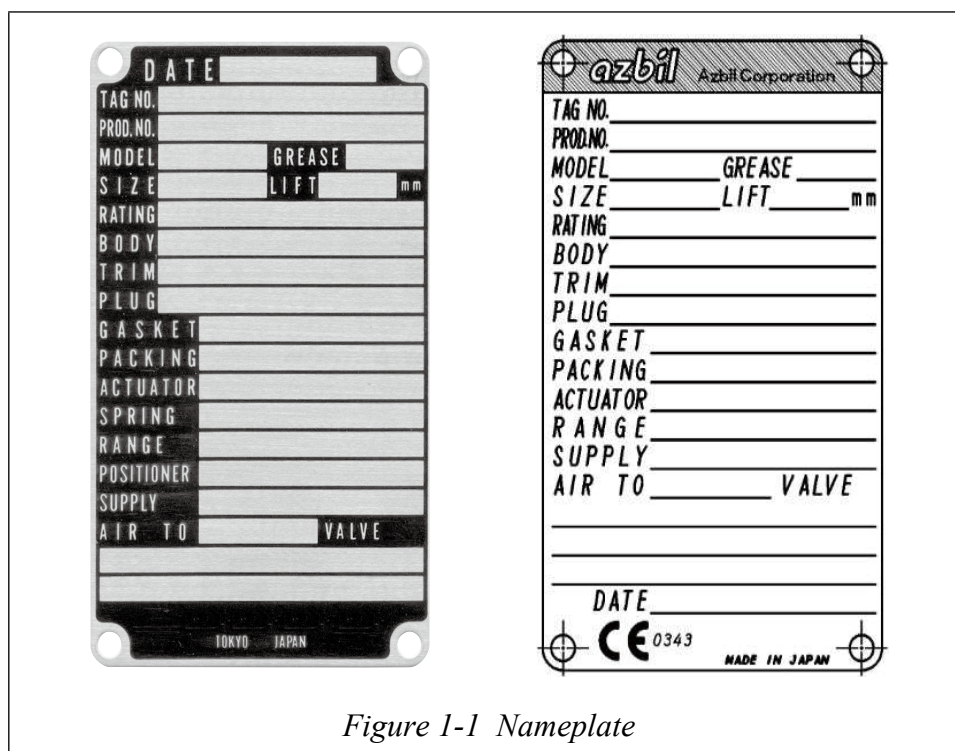

Figure 1-1 Nameplate

### Compliance with Regulations

This product complies with the directive below.

- Pressure Equipment Directive (PED) 2014/63/EU

### Requirements for workers (installation, operation, maintenance)

To ensure safety, only specialists who are skilled in instrumentation work should carry out the installation, operation, and maintenance of this device.

# 1-2 : Installation on piping

- (1) Before installing the valve, remove scale, welding chips and other foreign material from both the upstream and downstream sides of the piping.
- (2) Pass the longer bolts through the lower half of the flanges to make up a cradle for the valve and place the valve on the cradle.

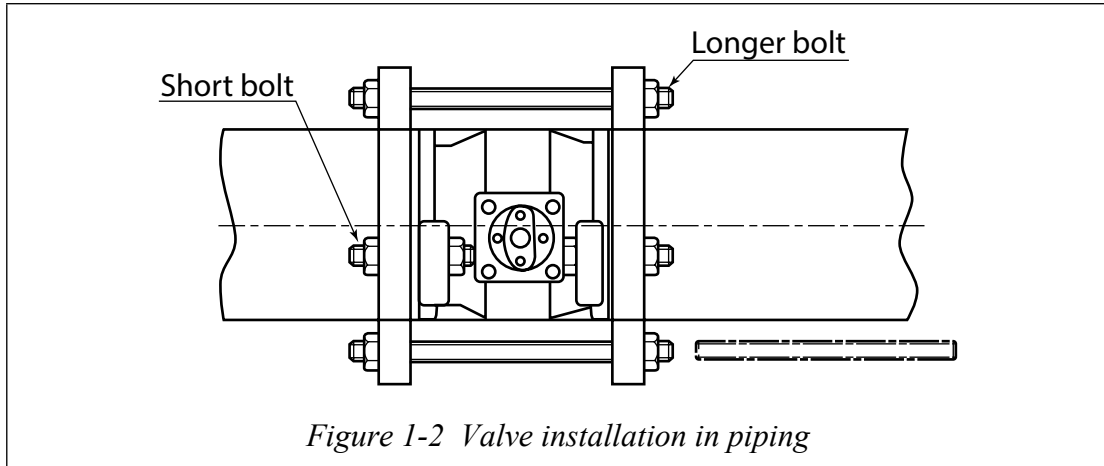

**Table 1-1 Valve installation in piping**

Valve size (inches)	Longer bolts			Shorter bolts		
	JIS 10K ANSI 150	JIS 20K	ANSI 300	JIS 10K ANSI 150	JIS 20K	ANSI 300
6	M20 × 350	M22 × 370	M20 × 380	M20 × 130	M22 × 140	M20 × 150
8	M20 × 380	M22 × 380	M22 × 410	M20 × 130	M22 × 130	M22 × 160
10	M22 × 440	M24 × 450	M27 × 490	M22 × 140	M24 × 160	M27 × 190
12	M22 × 480	M24 × 500	M30 × 540	M22 × 140	M24 × 160	M30 × 200

- (3) Place the gasket for piping and pass the longer bolts through the upper half of the flanges. For the mounting bolts, see Figure 1-2, and Table 1-1.

**~Note** Use the shorter bolts in such places where the longer bolts will interfere with the packing box.

- (4) Align the center of the valve with that of the piping and tighten the bolts evenly.
- (5) Make sure that the direction of the arrow mark stamped on the valve body conforms with the direction of the process fluid flow in the piping.
- (6) Pay attention so that the piping connection gaskets do not protrude into the inside of the piping. Be sure to use gaskets of materials suitable to the type and temperature of the fluid to be controlled.
- (7) After installing the valve and connecting the air piping, blow the air piping clean to remove any dust and foreign material from inside the air piping.
- (8) Do not install any heating or cooling provisions for the bonnet section.

**~Note** The mounting attitude of the valve can be changed by altering the mounting position of the actuator. See “Chapter 5 : Changing the mounting attitude of actuator and type of valve action” for procedures.



## 1-3 : Inspecting and maintaining the installed valve

Follow the procedures given below when inspecting or servicing an installed valve.

- (1) Verify that there is no leak from the air piping.
- (2) Verify that there are no loose clamping-bolts or nuts on the diaphragm case.
- (3) Verify that there is no leak from the gland packing. Tighten the packing flange nuts as required.
- (4) Verify that there is no leak from the piping gaskets and check for loose clamping bolts and nuts.
- (5) To lubricate a valve which is equipped with a lubricator, proceed as follows:

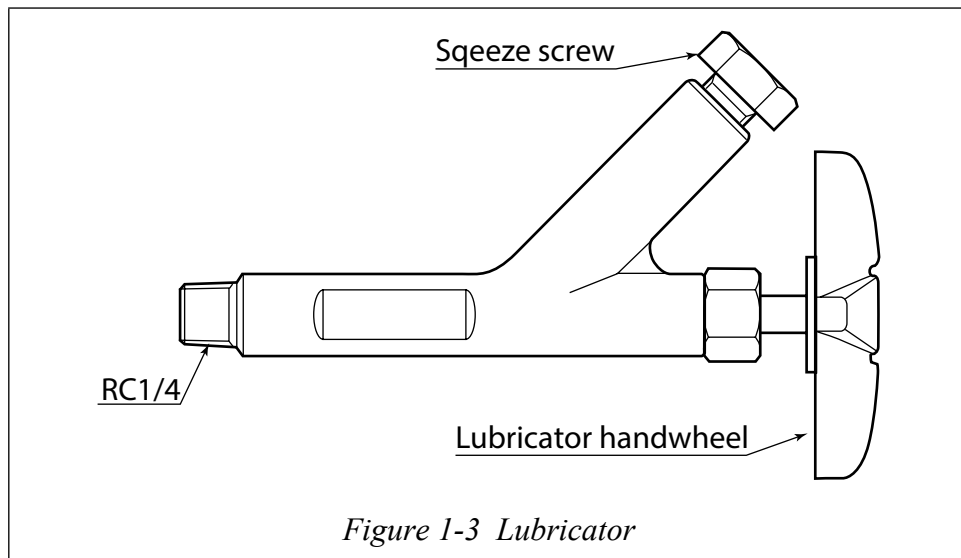

- (a) Prepare the correct type of grease by referring to the grease number written on the nameplate.
- (b) Tightly close the lubricator handwheel.
- (c) Remove the squeezer and apply grease.
- (d) While opening, squeeze grease into the valve by rotating the squeezer.
- (e) Repeat steps (b), (c) and (d) until grease is sufficiently fed into the valve. Then, close the lubricator handwheel.



# Chapter 2 : Valve Body

## 2-1 : Description

Figure 2-1 shows a cutaway view of the valve body section of the model VFR eccentric rotary valve. The valve body section consists of a valve body and a bonnet constructed as a single unit, and of a valve plug, a seat ring, and other trim parts. Cross sections and nomenclature of the valve body section are shown in Figure 2-2.

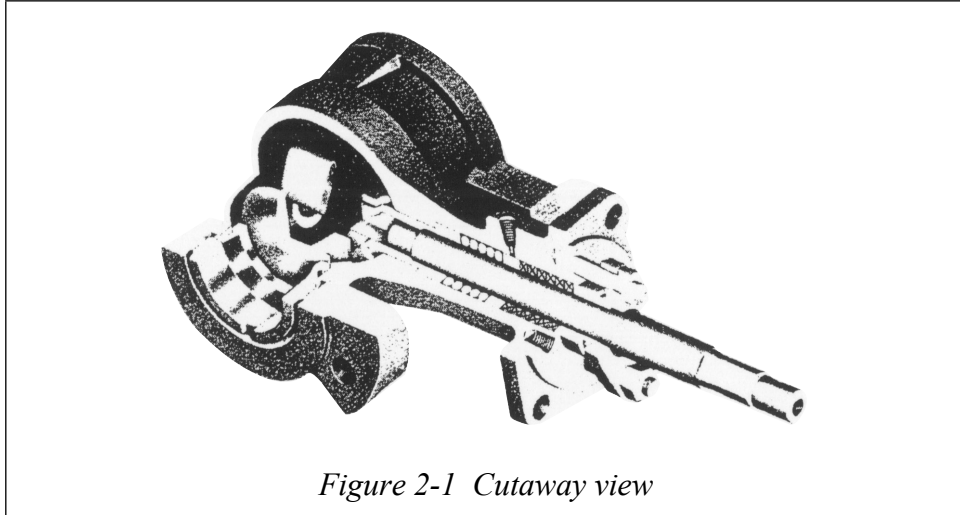

*Figure 2-1 Cutaway view*

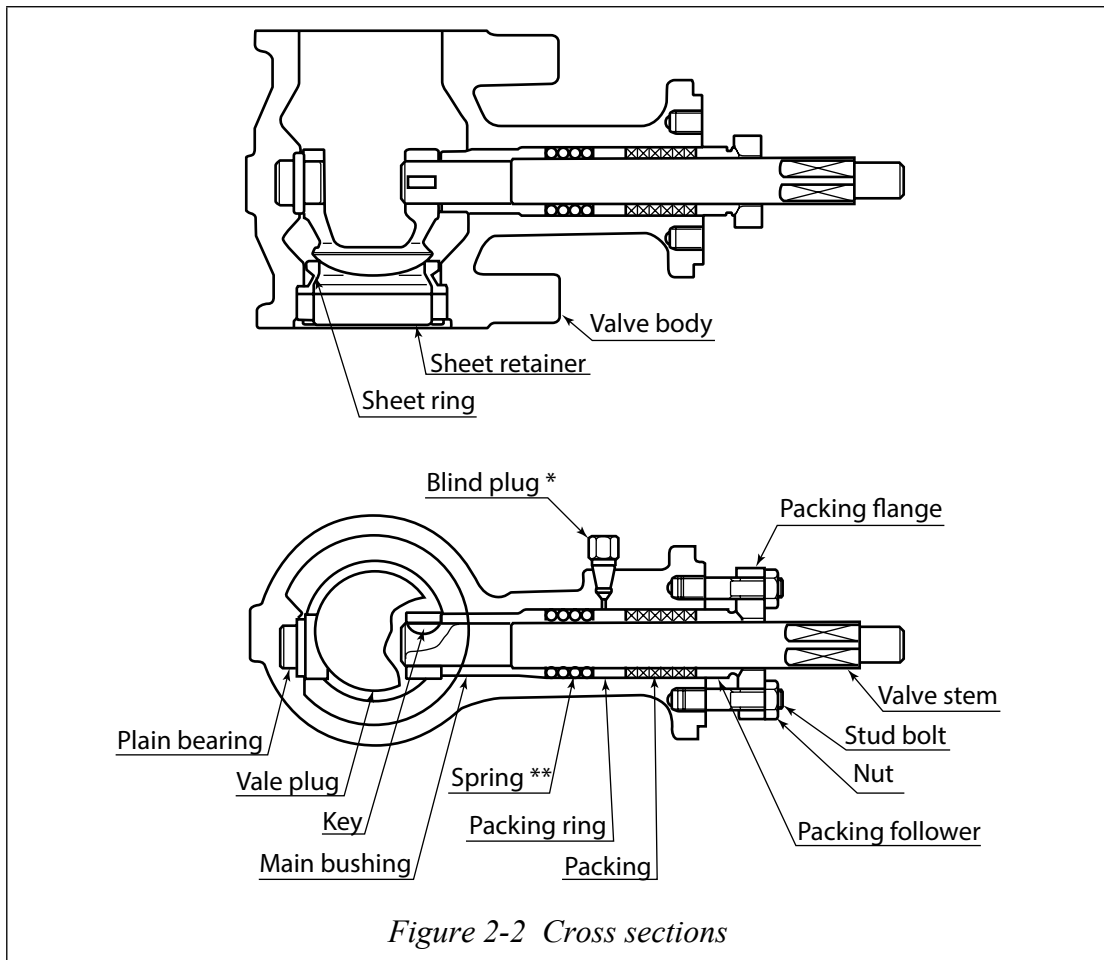

Figure 2-2 Cross sections

\*: For a valve without lubricator

\*\* : For a valve with lubricator, this space must be filled with packing instead of the spring.

## 2-2 : Disassembly

For the disassembly of the valve body section, dismantle the actuator observing the disassembly instructions described in “Chapter 3 : Actuator” and then proceed as follows:

- (1) Remove the clamping-bolts from the packing flange.
- (2) Remove the packing flange and packing follower.
- (3) Pull out the valve stem together with the other gland parts (key, main bushing, spring, packing ring, and packing). (For 10 in. and 12 in. valves, pull out the valve stem alone.)

**~Note** *If the valve stem does not readily come out, pull it out using the following procedure:*

- (a) *Remove several pieces of packing.*
  - (b) *Prepare a pipe, a stud bolt, a nut and a washer as shown in Figure 2-3 and turn the nut so to pull the valve stem out. (When installing the cam holder on the end of the valve stem, apply locking agent.)*
- (4) Remove the valve plug from the plain bearing.
  - (5) Pull the valve plug out from the downstream side.
  - (6) Remove the seat retainer by turning it counterclockwise with a seat ring remover-clamper (a special tool available separately). For the seat ring remover-clamper, see Figure 2-4.
  - (7) Remove the seat ring. Inspect all of the removed parts and replace defective ones, if any, with new ones.

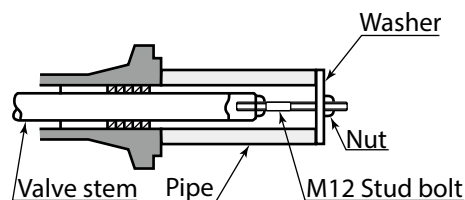
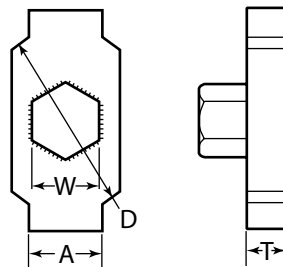

Figure 2-3



(inches)	A	T	D	W
6	19.5	15	128	30
8	19.5	15	164	30
10	39.5	20	194	32
12	39.5	20	232	32

Figure 2-4 Seat ring remover-clamper

## 2-3 : Assembly

- (1) Inset the valve plug into the valve body and press it against the plain bearing.
- (2) Insert the valve stem into the main bushing and insert the key in the key slot of the valve stem. (See Figure 2-5.)
- (3) Insert the valve stem into the valve body and slide the key through the key slot of the valve plug. (See Figure 2-5)

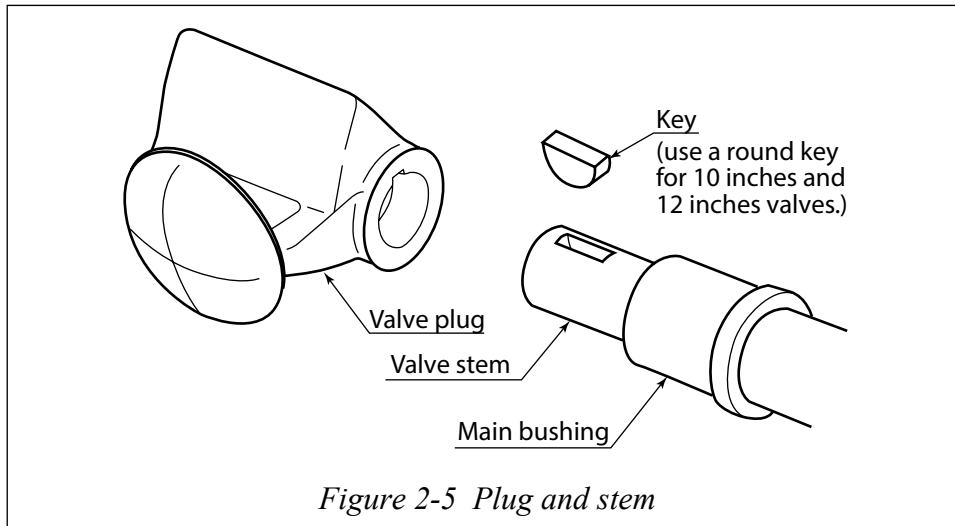

- (4) Install the gland parts. For the packing, pay attention to whether the valve is with or without a lubricator. For assembly, see Figure 2-6.

**~Note** *Insert packing in such a manner so that their ends are positioned alternately.*

- (5) While holding the valve plug open, install the seat ring and finger tighten it with the seat retainer.

- (6) Turn the valve stem so that the valve plug presses against the seat ring, then tighten the seat retainer with the seat ring remover-clamper.

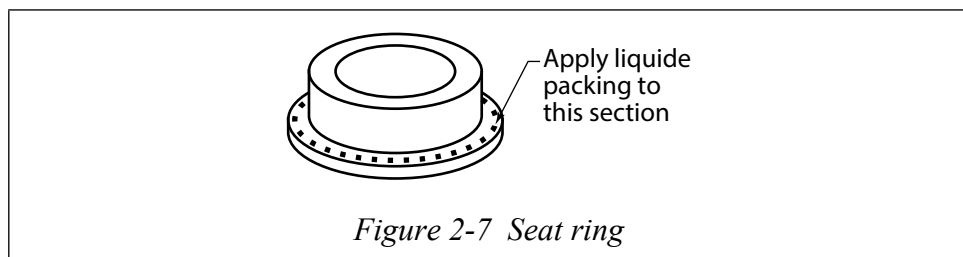
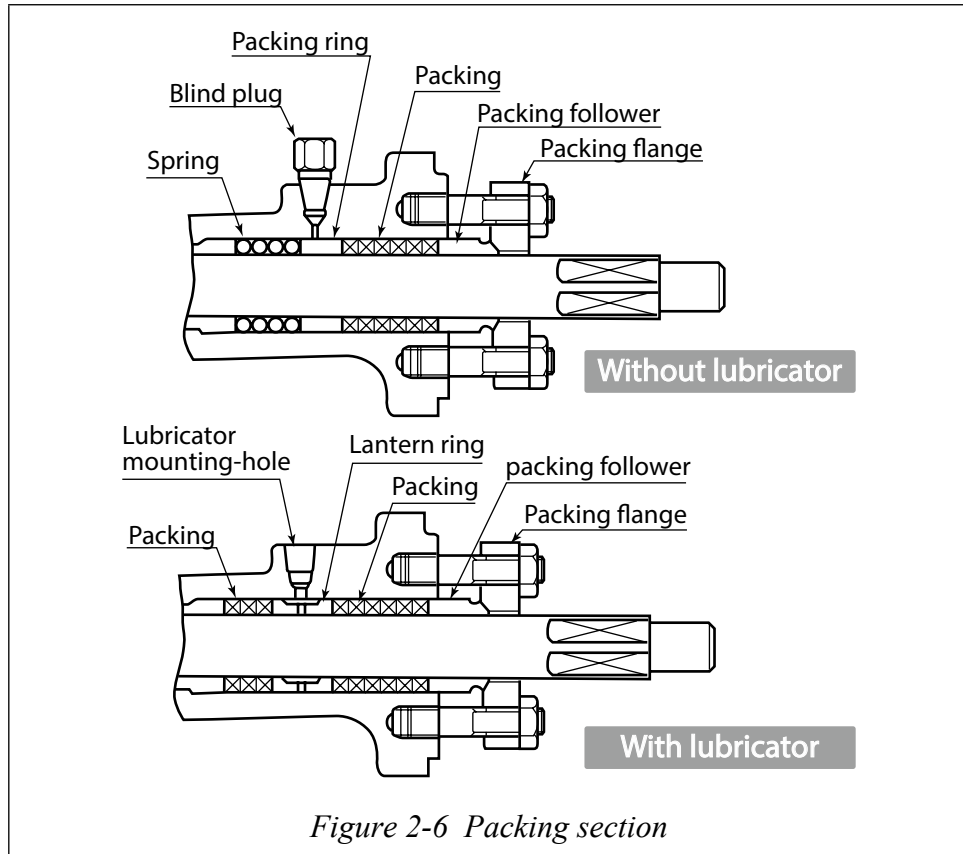





# Chapter 3 : Actuator

## 3-1 : Description

The model VR Actuator is a pneumatic and spring type diaphragm motor designed specifically for rotary type control valves. It holds the valve plug in a position where the pneumatic force and pneumatic force are mutually balanced.

For proportional control a dedicated posiitoner has been incorporated.

Valve position can be manually adjusted using the handwheel. As the handwheel is rotated counterclockwise\*, the actuator stem moves downward. (The open/close directions are indicated on the direction indicator plate on the handwheel.)

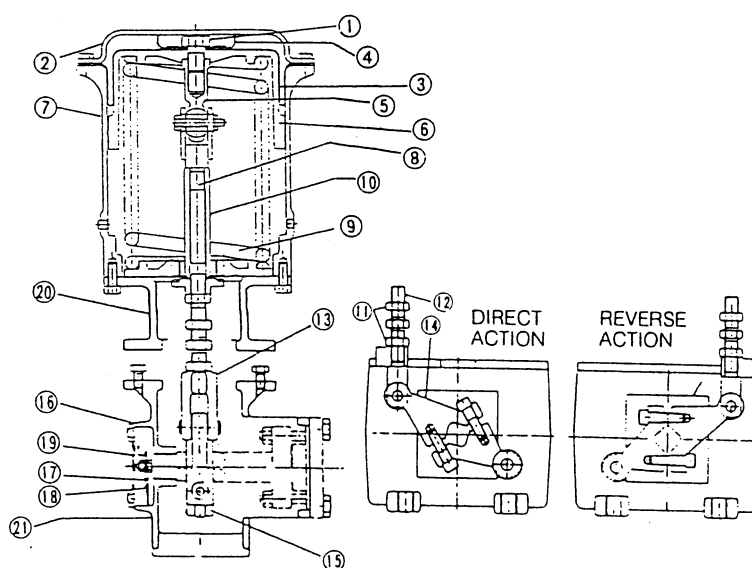

Figure 3-1 Structure of the actuator

No.	Parts name	No.	Parts name
1	Diaphragm clamping-nut	12	Turnbuckle
2	Diaphragm case (Top)	13	Fork
3	Diaphragm	14	Clamp
4	Stopper	15	Roller
5	Rod end bearing	16	Bearing cover
6	Piston	17	Pointer
7	Case	18	Cam
8	Actuator stem	19	Scale
9	Spring	20	Intermediate bracket
10	Spring compression nut	21	Bracket
11	Locknut		

## 3-2 : Adjusting the actuator

The actuator requires to be adjusted if its action starts to shift or after it has been overhauled. Before adjusting the actuator, turn the manual handwheel to the fully clockwise position as viewed from the direction indicator plate. (See Figure 3-14)

- (1) Connect the air piping to the actuator through a pressure regulator.
- (2) Loosen the lock nuts on the turnbuckle and then loosen\* the turnbuckle.

**~Note** \* : *Of the turnbuckle, the fork side is with a right-handed thread and the actuator side is with a left-handed thread. (See Figure 3-2 and Figure 3-4)*

- (3) By adjusting the pressure regulator, apply to the actuator a pressure corresponding to the upper limit of the spring range if the valve is in direct-action mode or a pressure corresponding to the lower limit of the spring range if the valve is in reverse-action mode.
- (4) Use a wrench to rotate the hex section of the turnbuckle until rotation becomes heavy and the parts on the clamp shaft do not turn any further. The turning directions are as follows:
  - For a direct-action valve, turn the spring compression nut clockwise\*.
  - For a reverse-action valve, turn the lock nut counterclockwise\*  
(\*: As viewed from the position shown in Figure 3-2.)
- (5) As is align the pointer with the S index of the scale.
- (6) Securely tighten the lock nuts of the turnbuckle.
- (7) For the adjustment of the positioner, see “Chapter 4 : Valve Positioner”.

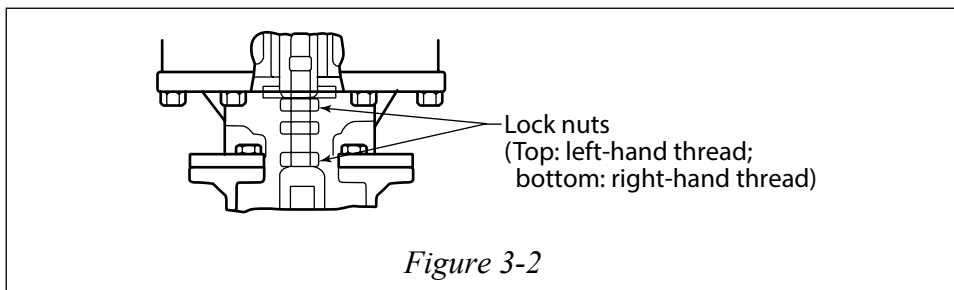

### 3-3 : Removing actuator from valve body

- (1) First, remove the positioner from the valve body referring to “Chapter 4 : Valve Positioner”.
- (2) After removing the positioner, remove the nut and then remove the cam and pointer from the valve stem end. (See Figure 3-3)

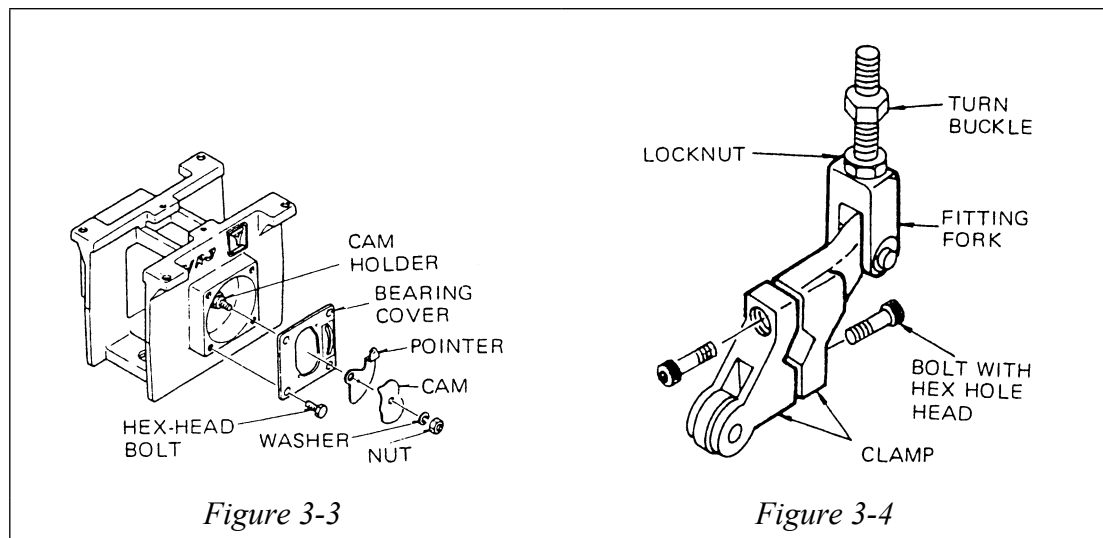

- (3) For a reverse-action valve, since the initial compression force is being applied to the actuator stem, loosen the locknut of the turn buckle and that of the fork and then loosen the turnbuckle.
- (4) Loosen the bolts (hex-hole head) of the clamps which connect the fork to the valve stem.
- (5) Remove the four bolts which clamp the yoke to the valve body and then remove the actuator from the valve body.

## 3-4 : Disassembly of actuator

To disassemble the actuator for parts replacement or servicing, follow the procedure described below. (See Figure 3-5.) When disassembling the actuator, take care not to damage the diaphragm or piston.

- (1) Loosen then remove uniformly the bolts and nuts of the diaphragm case (top).  
Remove the diaphragm case (top).
- (2) Hold the bead section of the folded diaphragm with both hands and pull it carefully upward. (See Figure 3-6.)

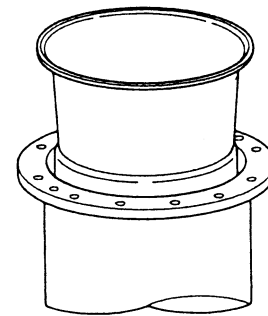
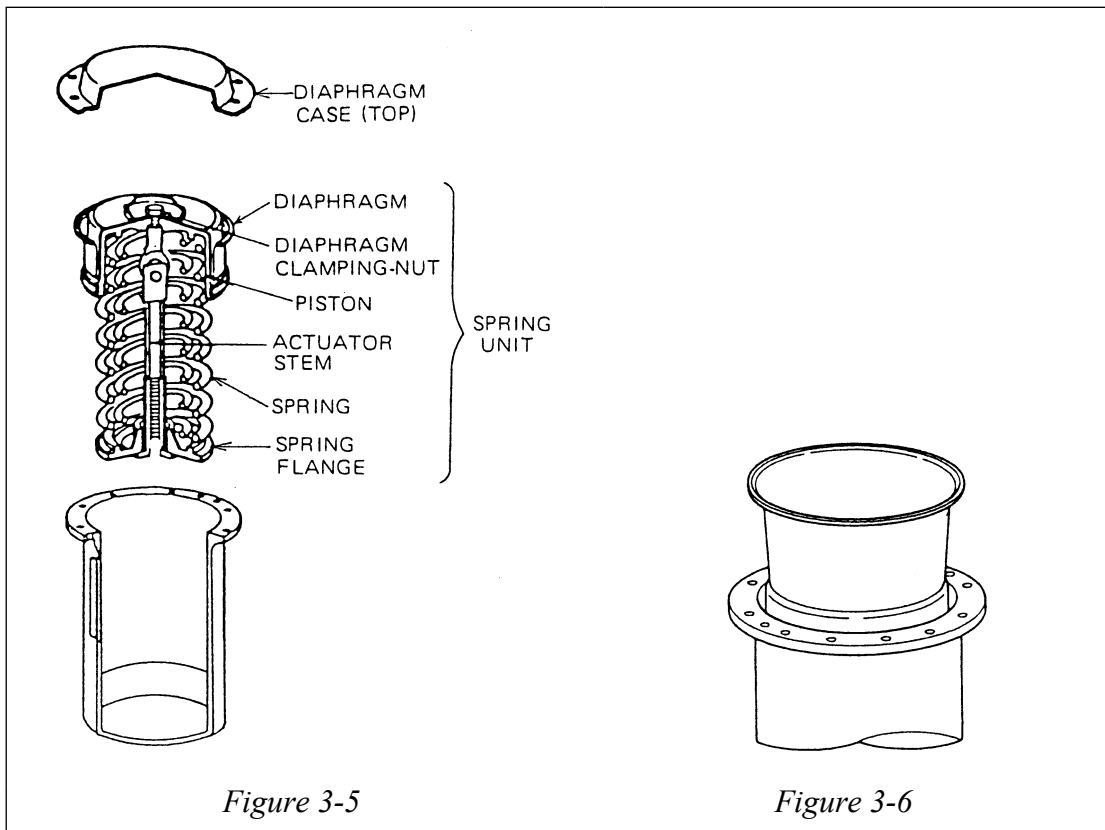

- (3) After removing the folded diaphragm, pass the fitting through the hole of the stopper and pull out the spring unit.
- (4) Loosen the anti-rotation lock nut and remove the fork from the end of the actuator.

- (5) Apply a wrench to the hex section of the actuator stem which has been pulled out and turn the spring compression nut counterclockwise to relieve the compression force of the spring. Then, remove the spring.

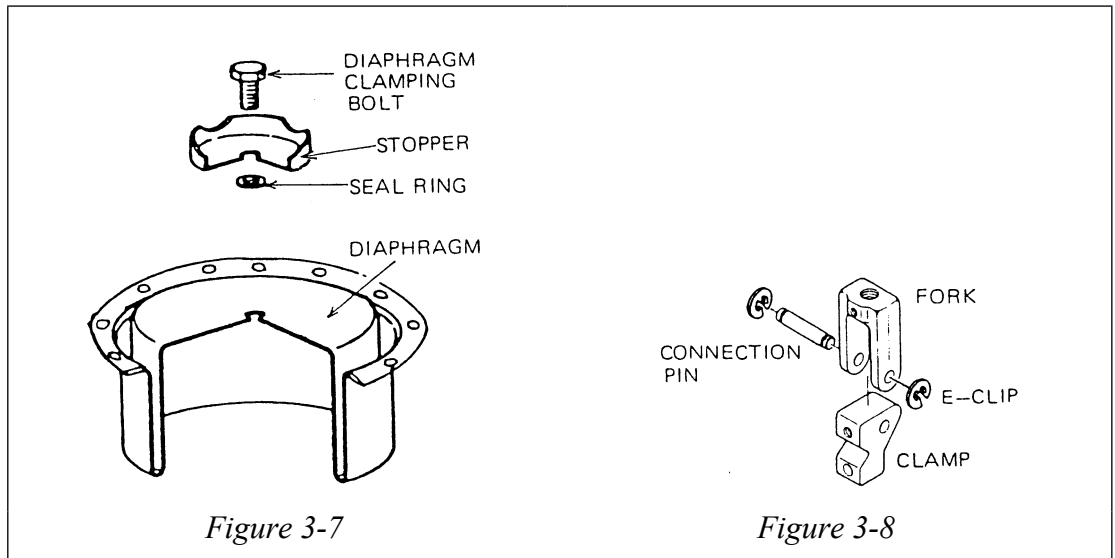

- (6) Next, while holding the outer section of the piston, remove the diaphragm clamping-bolts from the top of the diaphragm section. (See Figure 3-7.)
- (7) For the disassembly of the fork and clamp, remove the E-clip and then disassemble them as shown in Figure 3-8.

## 3-5 : Assembly of actuator

Since the mounting positions of parts differ depending on whether the valve is for direct action or reverse action, confirm the valve action by referring to the nameplate prior to assembling the actuator.

For the assembly of the actuator, proceed as follows:

- (1) Assemble the parts by following in the reverse order steps (6) through (8) of subsection "3-4 : Disassembly of actuator" and assemble the spring unit.

- ~Note**
1. *Compress the spring as far as the actuator stem and spring compression nut can turn.*
  2. *To assemble the fork and clamp, pay attention to the direction of the convex section of the fork and assemble them as shown in Figure 3-9.*
  3. *Apply a liberal amount of molybdenum disulfide powder ( $MoS_2$ ) onto the piston surface contacting with the diaphragm, the front and back surfaces of the diaphragm and the inside of the case contacting with the diaphragm.*

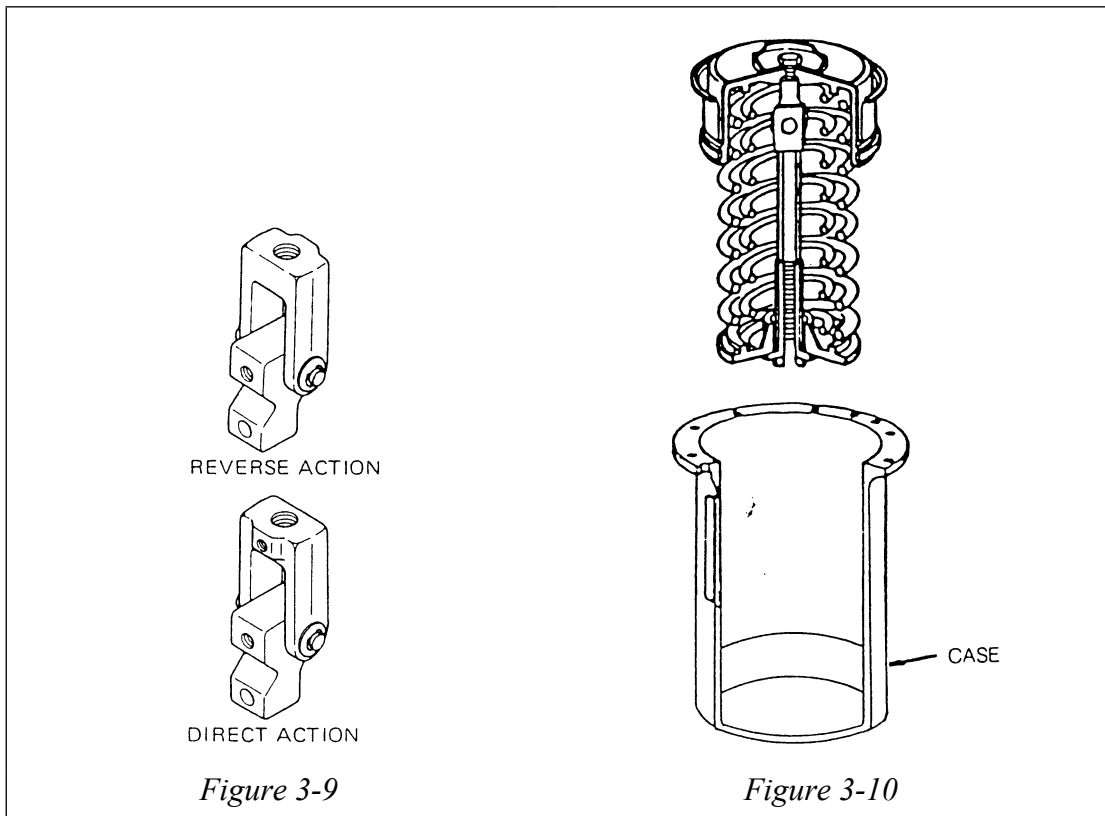

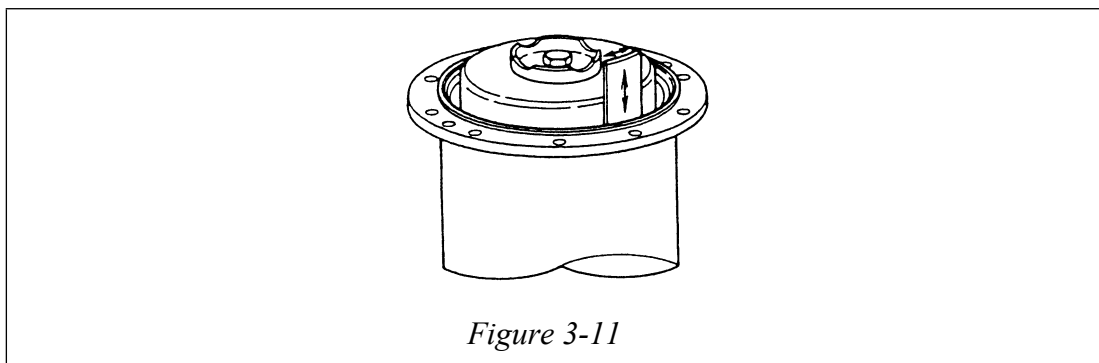

Figure 3-11

- (2) Place the assembled spring unit into the case following, in the reverse order, steps (4) and (5) in subsection “3-4 : Disassembly of actuator”. In this case, do not hold the assembly by its diaphragm. (See Figure 3-10.)
- (3) Fold the cup-shaped diaphragm into the case using a soft plate and pay attention not to scratch the diaphragm. (See Figure 3-11.)

- ~Note**
- 1: Fold the diaphragm so that its circumference uniformly contacts the flange surface of the case.
  - 2: Regarding the diaphragm, pay attention to the mounting position of the spring unit so that the gap between the inside circumference of the case and the outside circumference of the piston becomes uniform.

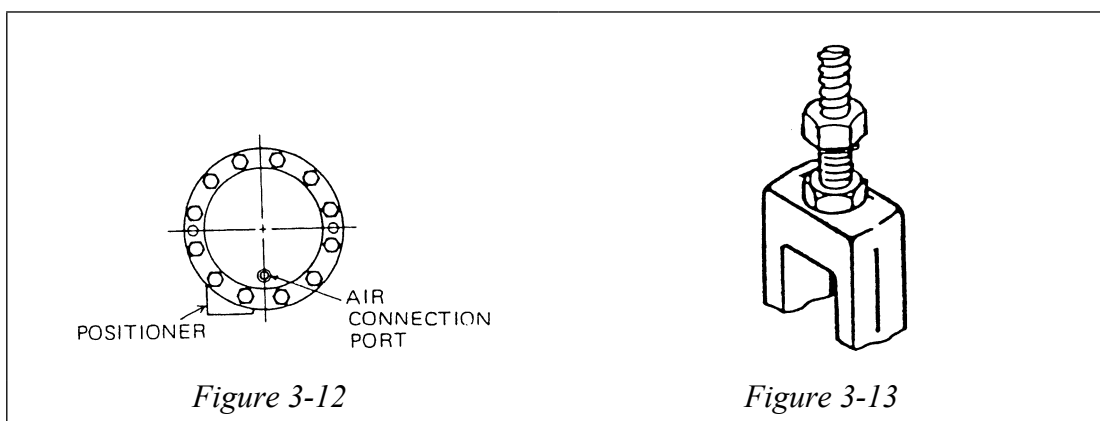

Figure 3-12

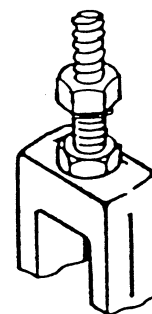

Figure 3-13

## 3-6 : Mounting actuator on valve body

To mount the actuator on the valve body, follow, in the reverse order, the procedure described in subsection “3-3 : Removing actuator from valve body”. After mounting the actuator, adjust the actuator as described in subsection “3-2 : Adjusting the actuator”.

## 3-7 : Manual device (Handwheel)

The manual device of the actuator can function as a limit stopper as well as its function as a conventional manual control device for the valve.

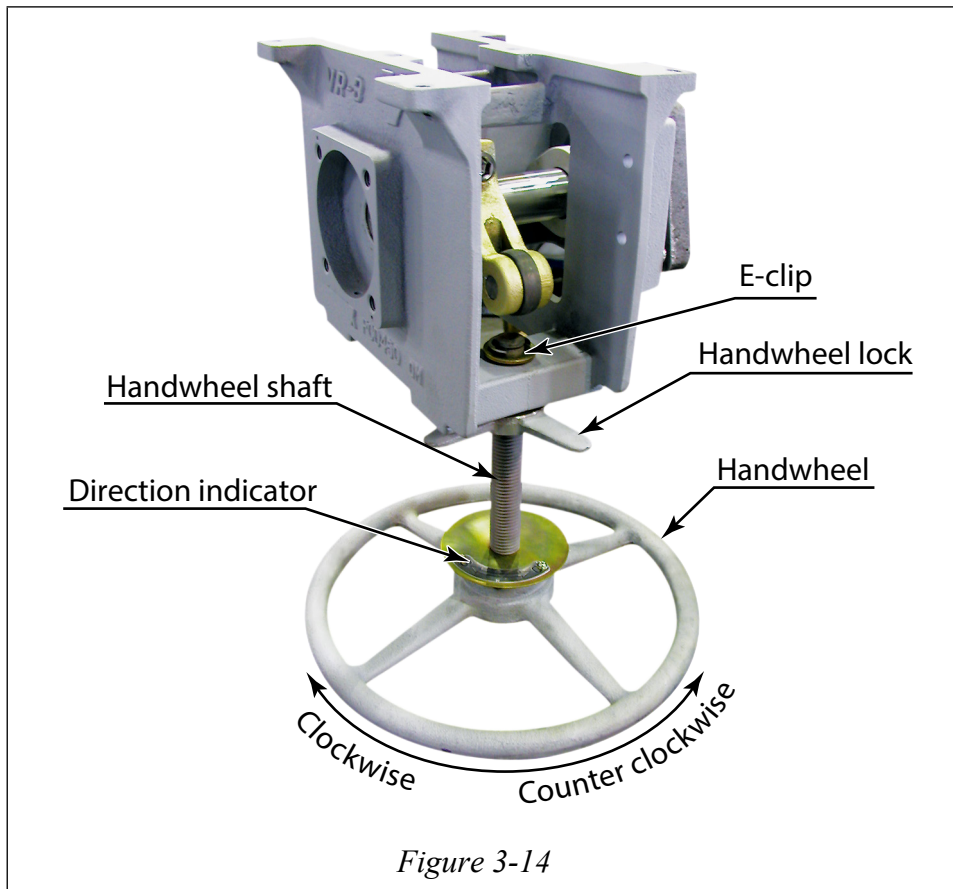

### 3-7-1 : Setting automatic operation

When the valve is to be operated in automatic mode, set the manual device as follows:

- (1) Release the handwheel lock by turning it clockwise (as viewed looking down towards the direction, indicator plate).
- (2) Pull the handwheel shaft out as far as it can by turning the handwheel clockwise.
- (3) Lock the handwheel by turning the handwheel lock counterclockwise.
- (4) Keep the handwheel as such while the valve is being operated in the automatic mode.



## 3-7-2 : Setting manual control

First, switch the bypass cock (See Figure 4-9) of the positioner to the “ON” position. If the handwheel lock is released and the handwheel is rotated counterclockwise as viewed down towards the direction indicator plate, the valve will close if it is a direct action type or it will open if it is a reverse action type.

For manual control of the flow using the valve, turn the handwheel to the desired position in the required direction referring to the direction indicator plate and tighten the handwheel lock to fix the valve to that position.

Be sure to set the valve as described in subsection “3-7-1 : Setting automatic operation” before commencing to operate the valve in automatic mode.

## 3-7-3 : Setting the limit stopper

The handwheel can be used also as a limit stopper - a stopper for a maximum aperture when in direct action mode or as a stopper for the minimum aperture when in reverse action mode.

- (1) Release the handwheel lock. Turn the handwheel to the desired position in the required direction referring to the direction indicator plate.
- (2) Tighten the handwheel lock.

For automatic operation without the limit stopping effect, set the handwheel as described in subsection “3-7-1 : Setting automatic operation”.



# Chapter 4 : Valve Positioner

## 4-1 : Smart Valve Positioner (SVP)

### 4-1-1 : Description

The SVP (Smart Valve Positioner) is an intelligent valve positioner that can be connected to a 4-20 mA controller output signal line. Since all adjustments can be performed electrically, the relationship between the input signal and the position of the control valve can be set arbitrarily. Split range and other special settings are also easy to set up.

### 4-1-2 : Removing and installing the positioner

#### Removal

- (1) Disconnect the air piping from the positioner.
- (2) Loosen the two clamping-bolts (M12, hex-hole head) with a hex wrench and remove the mounting plate from the bracket.
- (3) Loosen the clamping-bolt (M10, hex-hole head) with a hex wrench and remove the feedback-pin and pointer and connector-plate.
- (4) Loosen the clamping-bolt between the bracket and the body. The positioner is now ready for removal.

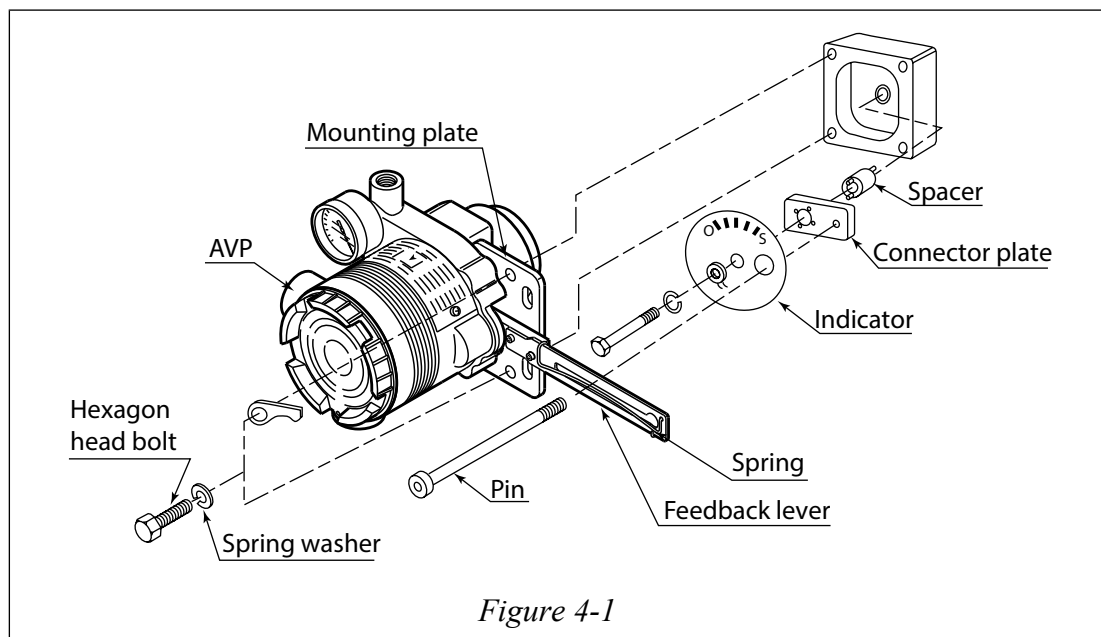

## Installation

- (1) Install the spacer onto the bracket.
- (2) Install the connector-plate onto bracket with feedback-pin. Since the position of spacer's pin changes by flow direction, attach with reference to Figure 4-2 and Figure 4-3.
- (3) Tighten the clamping-bolt (M10, hex-hole-head) and attach the indicator to the connector-plate, and then tighten the clamping-bolt (M12, hex-hole head) and attach the pointer and mounting-plate.
- (4) Connecting the air piping.

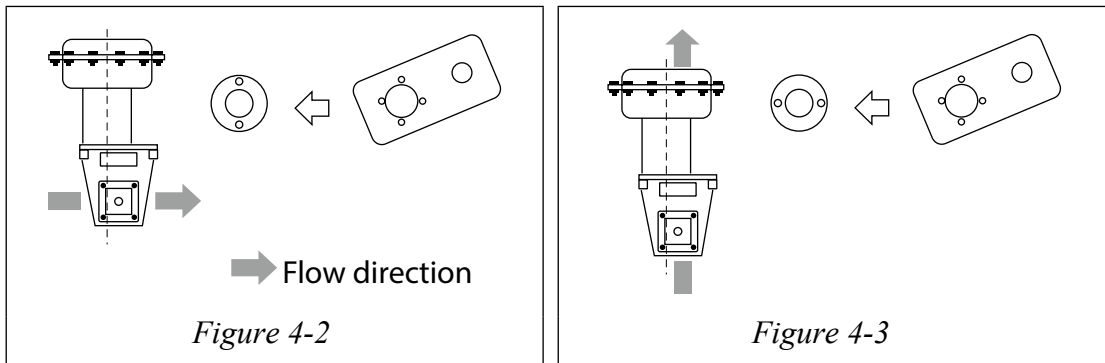

### 4-1-3 : Adjusting the positioner

For details on positioners, refer to the respective manuals listed below.

CM2-AVP300-2001 } for SVP  
 CM2-AVP303-2001 }

### 4-1-4 : Maintaining the positioner

For details on positioners, refer to the respective manuals listed below.

CM2-AVP300-2001 } for SVP  
 CM2-AVP303-2001 }

### 4-1-5 : Troubleshooting

For details on positioners, refer to the respective manuals listed below.

CM2-AVP300-2001 } for SVP  
 CM2-AVP303-2001 }

## 4-2 : Pneumatic valve positioner (model VFR)

### 4-2-1 : Description

The valve positioner is mounted on the model VR actuator and has the function of positioning the valve plug accurately and rapidly to a position corresponding to the pneumatic signal received from the controller.

The valve positioner consists of the following components:

- Input gauge
- Output gauge
- Bypass cock
- Input bellows
- Flapper-nozzle mechanism
- Pilot relay
- Cam
- Cam follower
- Feedback spring
- Feedback lever

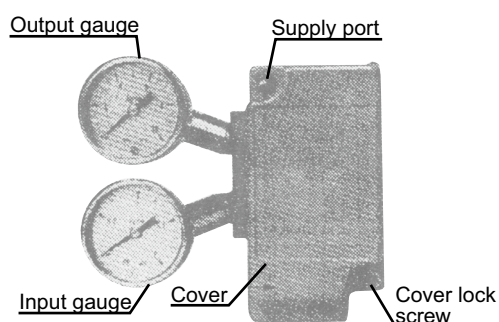

Figure 4-4 Front view

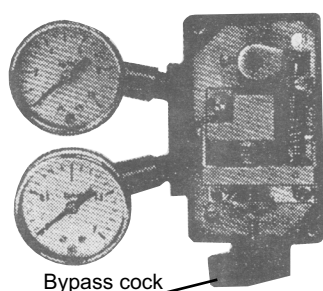

Figure 4-5 View when cover removed

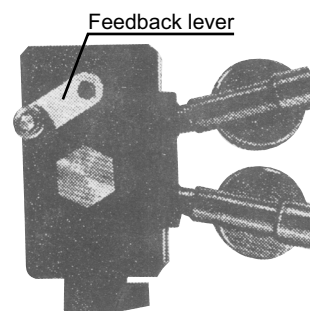
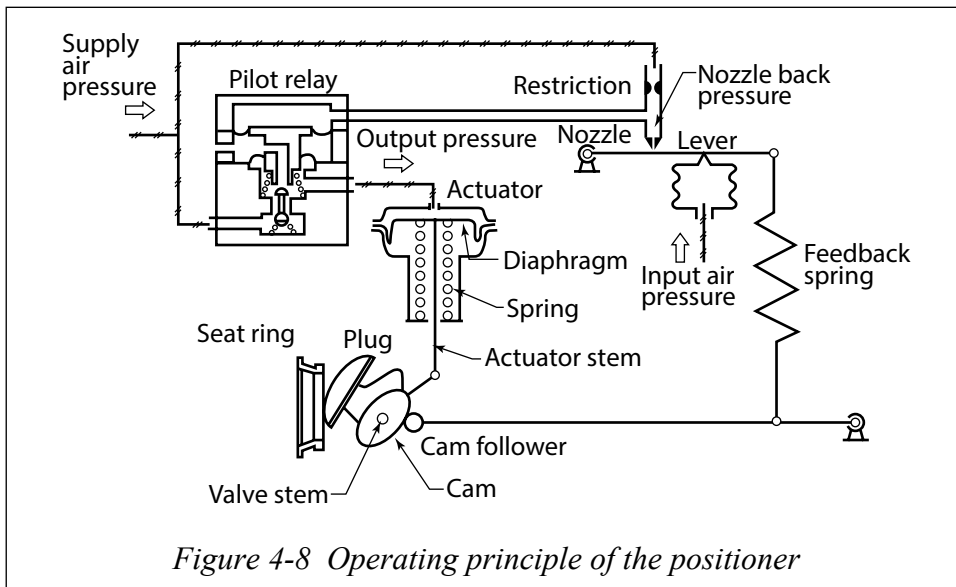
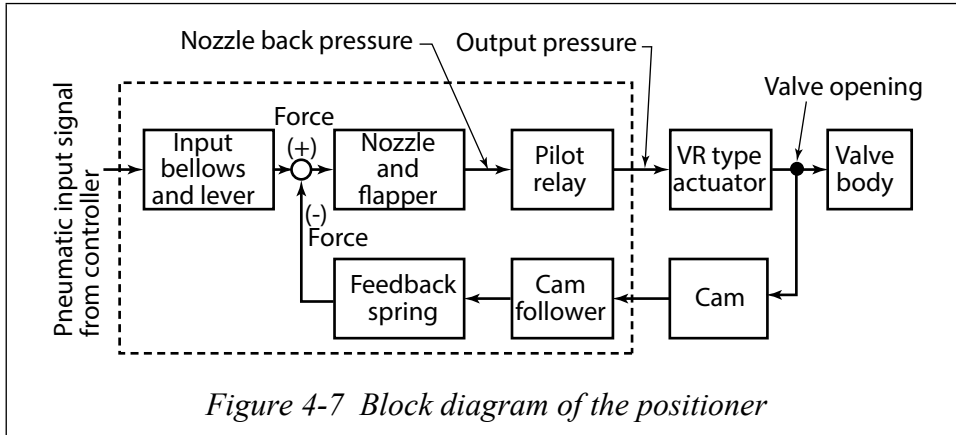

Figure 4-6 Rear view

## 4-2-2 : Operating principle

The valve positioner employs a force balance mechanism. See Figure 4-7 and Figure 4-8 for its operating principle.



## 4-2-3 : Bypass cock

### Function of bypass cock

The supply air bypass cock mechanism is provided on the bottom of the valve positioner. It is used to switch between the “ON” for “operation with positioner” and “SUP” for “operation with the supply air” as shown in Figure 4-9. When switched to “SUP”, the supply air bypasses the pilot relay and it is fed directly to the actuator, thereby enabling the following two things:

- (1) The valve opening can be directly controlled by the supply air.
- (2) As the pilot relay is isolated from the supply air and output air, the pilot relay can be inspected or serviced simply by shutting off the input signal air.

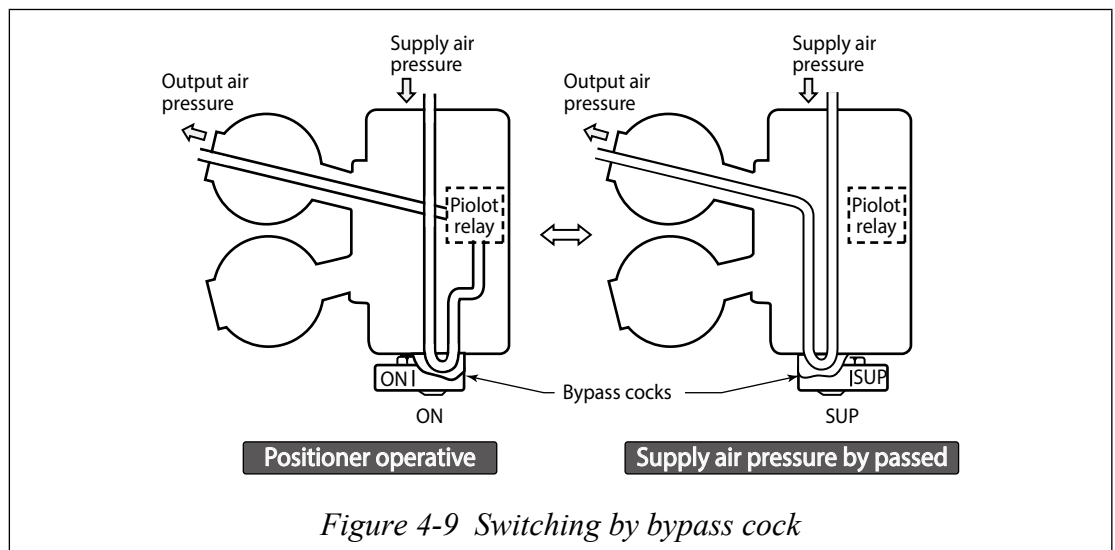

### Installing the bypass cock

To install the bypass cock which has been removed for gasket replacement or some other servicing, install it while referring to Figure 4-10. In this case, apply silicone grease sparingly to the surfaces of the gasket. If a new gasket is to be used, place it so that its white surface faces out. After fully tightening the mounting screw (cross-hole head), loosen it by a 1/3 to 1/4 turn.

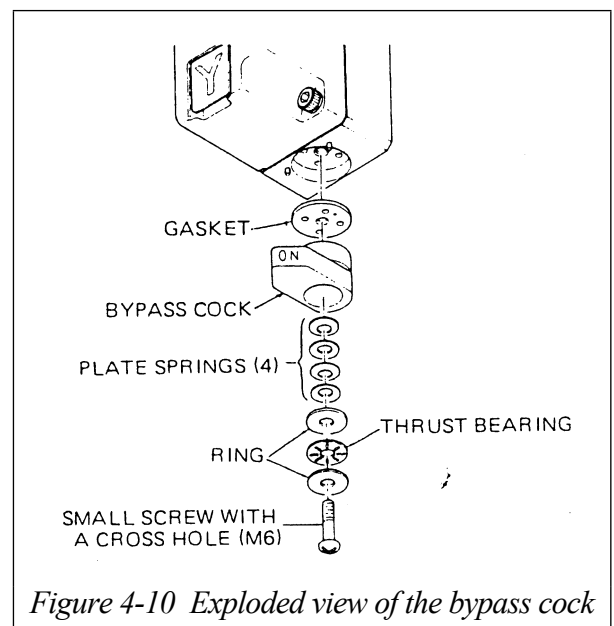

## 4-2-4 : Selecting cam characteristics

To change valve characteristics Select a proper cam and install it. (For installation and adjustment procedures, refer to the respective sections.)

### Cam characteristics

A single sheet of cam for the positioner can satisfy either linear characteristics or equal-percent characteristics.

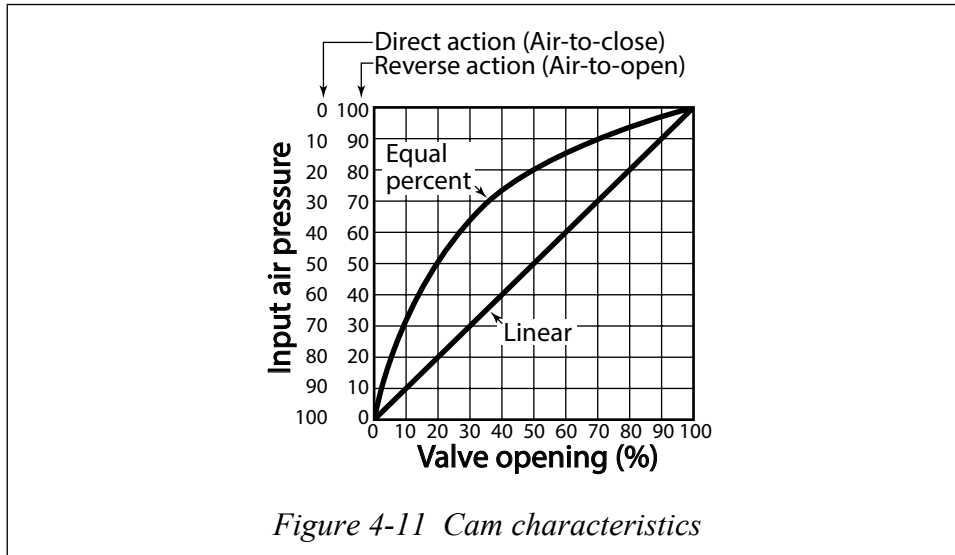

Figure 4-11 Cam characteristics

### Using the equal-percent cam

When the inherent characteristics of the valve is linear but equal-percent characteristics are required by the process, control characteristics of the valve can be converted into the equal-percent type simply by using an equal-percent cam.

### Selecting a cam

Select a proper cam as follows:

- (1) Confirm whether the valve is a direct action (air-to close) or reverse action (air-to-open) type.
- (2) Refer to Figure 4-12, and then select a cam which will provide the required flow characteristics for the process.

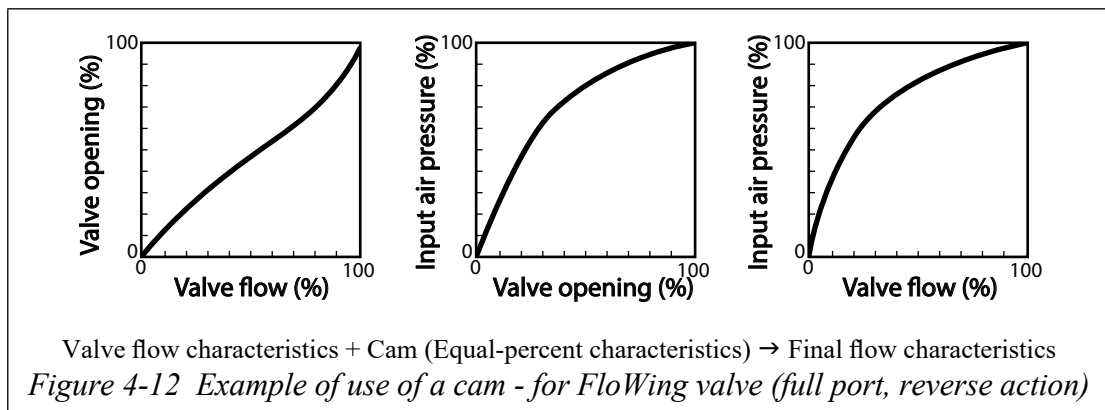



## 4-2-5 : Removing and installing the positioner

### Removal

- (1) Disconnect the air piping from the positioner.
- (2) Loosen the two clamping-bolts (M5, hex-hole head) with a hex wrench (4 mm) and remove the positioner cover. (See Figure 4-13.)
- (3) Loosen the two inner clamping-bolts (M6, hex-hole head) with a hex wrench (5 mm). The positioner is now ready for removal. (See Figure 4-14.)

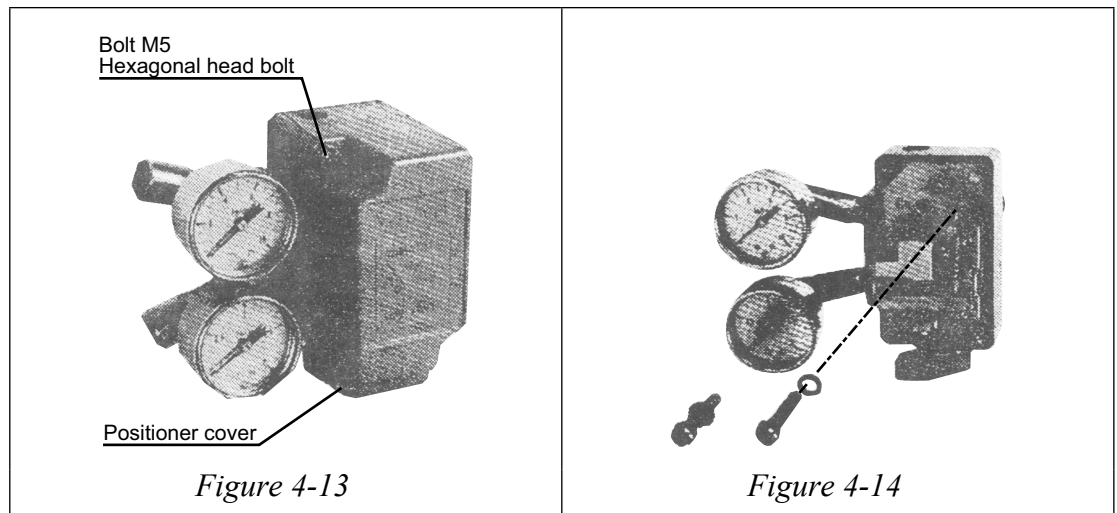

### Installation

For the adjustment of a positioner after its installation has been completed, see subsection “4-2-6 : Adjusting the positioner”.

- (1) Confirming the actuator specifications and cam characteristics
 

By referring to the nameplate, confirm the following three items:

  - (a) Direct action (air-to-close) or reverse action (air-to-open)
  - (b) Spring range of the actuator
  - (c) Cam characteristics
- (2) Installing the indicator and cam
  - (a) Connect the air piping to the actuator and apply an air pressure referring to the table shown below. When this is done, the valve will be fully closed irrespective of the type of actuator action (direct action or reverse action).
 

(Example: If the actuator is of the reverse action type and the spring range is 98 to 200 kPa {1 to 2 kg/cm<sup>2</sup>}, apply an air pressure of 98 kPa {1 kg/cm<sup>2</sup>} to the actuator.)

Valve action	Air pressure applied to actuator
Direct action	A pressure corresponding to upper limit of actuator spring
Reverse action	A pressure corresponding to lower limit of actuator spring

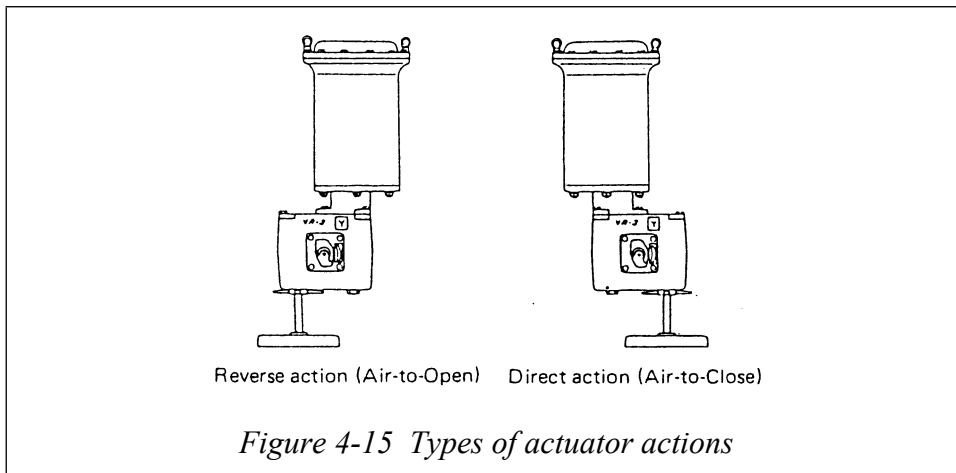

- (b) Install the indicator and cam onto the male-threaded section of the cam holder.
- (c) Select a setting hole of the cam that corresponds to the actuator action and cam characteristics referring to Figure 4-16 and set the selected hole onto the boss of the indicator.

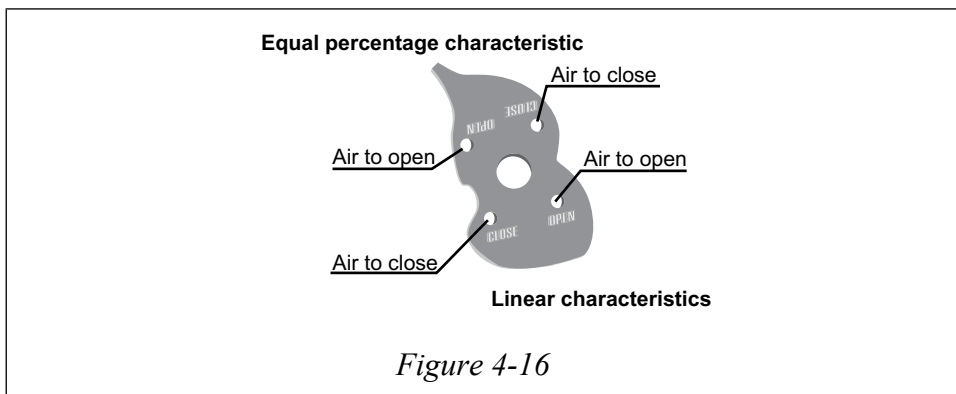

- (d) Engage the indicator with the cam holder serration in such a manner that the linear section of the indicator becomes as parallel as possible with the imaginary line of the reference line on the bearing cover. Fix the cam in this position with the spring washer and nut (M8). (See Figure 4-17.)

- (e) Release the air pressure applied to the actuator and disconnect the air piping.

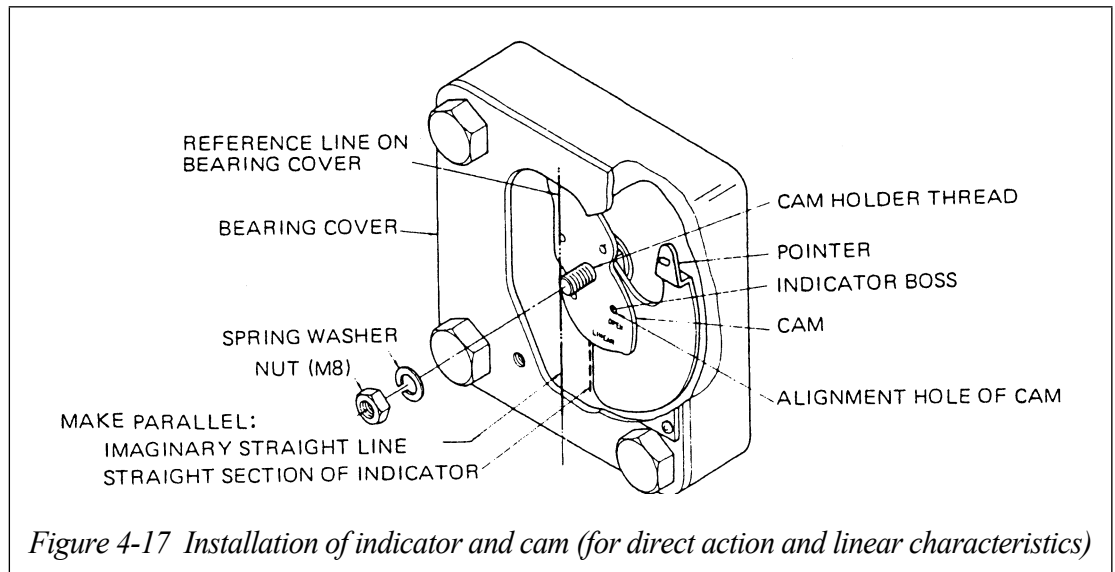

### (3) Installing the positioner

- (a) Loosen the two clamping-bolts (M5, hex-hole head) with a hex wrench (4 mm) and remove the positioner cover.
- (b) Mount the positioner (in such an attitude that the bypass cock is points downward) on the bearing cover with two bolts (M6, hex-hole head) and spring washers using a hex wrench (5 mm).

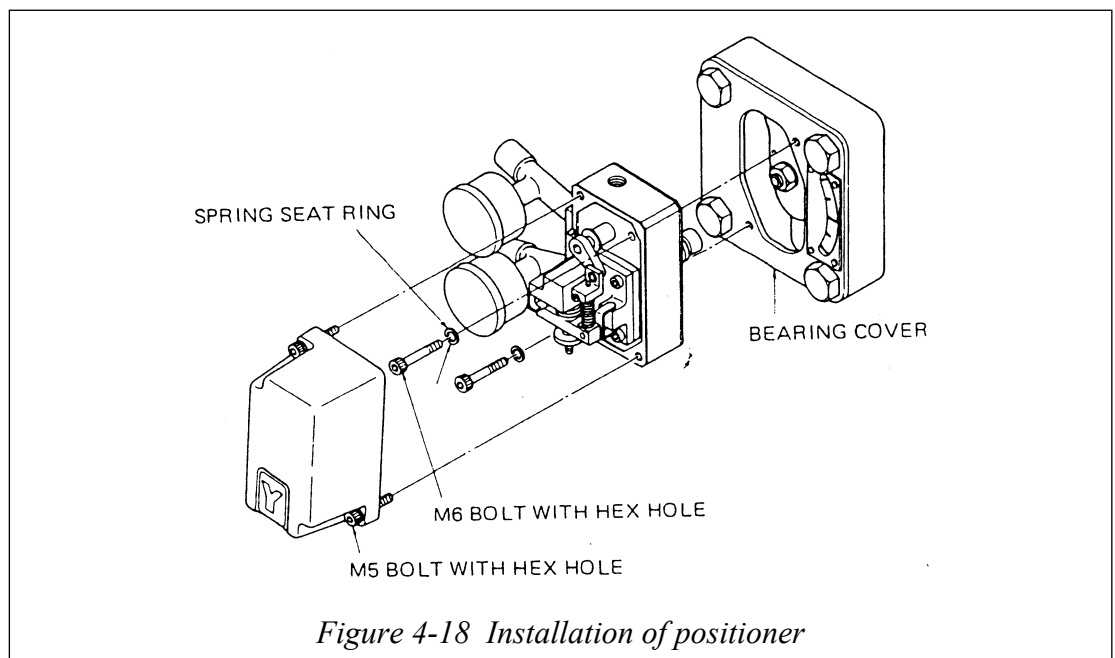

### (4) Connecting the air piping

Proud air piping between the union joint and the three air connection ports (IN, SUP, OUT; PT 1/4 tap thread) on the side plate of the positioner.

- IN : Input pneumatic pressure from controller  
 SUP : Air supply  
 OUT : Output pneumatic pressure to actuator

**~Note** Apply liquid packing to the threaded sections of the connectors. Do not use seal tape lest air paths of the positioner should become clogged.

## 4-2-6 : Adjusting the positioner

The positioner installed on a valve has been factory adjusted before shipment. When it has been replaced, however, the newly installed positioner is required to be adjusted in the following procedure.

- (1) Switch the bypass cock to “ON”.
- (2) Confirm the positioner input air pressure range, supply air pressure and actuator spring range by referring to the nameplate.
- (3) Feed the supply air to the positioner.
- (4) The procedures hereunder are divided into steps for a direct-action positioner and those for a reverse-action positioner, and assume an input air pressure range of 20-98 kPa {0.2-1.0 kg/cm<sup>2</sup>} for both cases.

\*1: If the input air pressure range of the positioner is 20-60 kPa {0.2-0.6 kg/cm<sup>2</sup>}, substitute 98 kPa {1.0 kg/cm<sup>2</sup>} with 60 kPa {0.6 kg/cm<sup>2</sup>} and 20 kPa {0.2 kg/cm<sup>2</sup>} with 60 kPa {0.6 kg/cm<sup>2</sup>} in the following steps.

### For direct action positioner (air-to-open)

- (5) Set the input air pressure to 20 kPa {0.2 kg/cm<sup>2</sup>}.
- (6) Turn the zero adjustment knob so that the output pressure of the positioner becomes the lower limit of the actuator spring range. When this is done, the indicator will indicate “S”.

(Example: If the spring range of the actuator is 98 - 200 kPa {1 - 2 kg/cm<sup>2</sup>}, set the output pressure of the positioner to 98 kPa {1 kg/cm<sup>2</sup>}.)

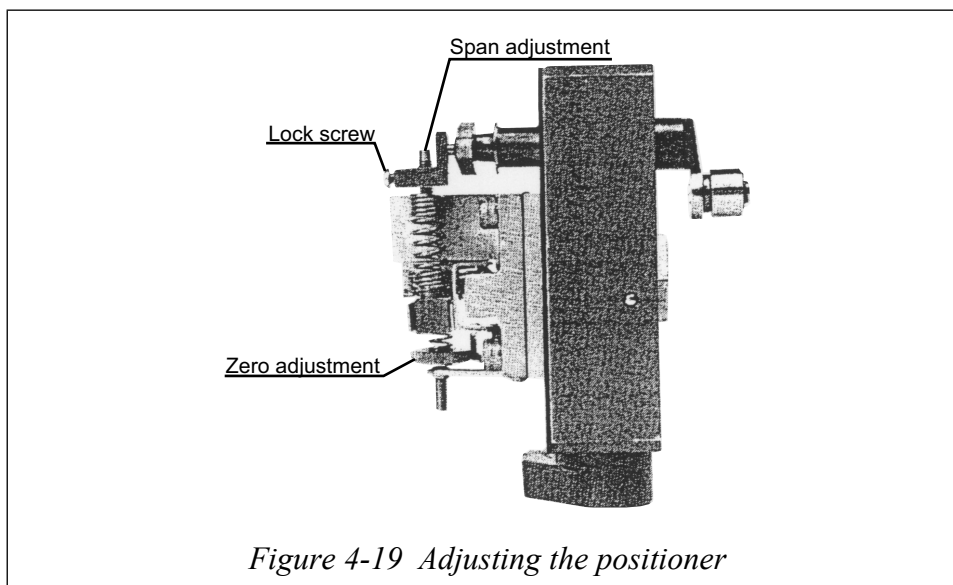

Figure 4-19 Adjusting the positioner

- (7) Set the input air pressure to 98 kPa {1.0 kg/cm<sup>2</sup>}.
- (8) Loosen the lock screw with a screwdriver (-) and adjust the SPAN control so that the indicator indicates “0”.

### For direct action positioner (air-to-close)

- (5) Set the input air pressure to 98 kPa {1.0 kg/cm<sup>2</sup>}.

- (6) Turn the zero adjustment knob so that the output pressure of the positioner becomes the upper limit of the actuator spring range. When this is done, the indicator should indicate “S”.  
(Example: If the actuator spring range is 98 - 200 kPa {1 - 2 kg/cm<sup>2</sup>}, set the output pressure of the positioner to 200 kPa {2 kg/cm<sup>2</sup>}.)
- (7) Set the input air pressure to 20 kPa {0.2 kg/cm<sup>2</sup>}.
- (8) Loosen the lock screw with a screwdriver (-) and adjust the SPAN control so that the indicator indicates “0”.
- (9) Repeat steps (5) to (8) several times.
- (10) After the adjustment has been completed, tighten the lock screw of the SPAN control with a screwdriver (-).

## 4-2-7 : Maintaining the positioner

### Operating precautions

- (1) Use only clean filtered air for the air supply, lest the nozzle or pilot relay should become clogged with foreign particles contained in the air supply.
- (2) When the positioner is installed outdoors, be sure to install the positioner so that the positioner cover is vertically positioned in order to prevent ingress of water.

### Troubleshooting

If the positioner experiences problems or it happens to malfunction, refer to the troubleshooting chart on page 4-13 and follow the procedures described therein.

### Cleaning the restriction

If the restriction has become clogged with foreign particles and the positioner starts malfunctioning, remove the M5 bolts (hex-hole head) and M3 bolt (hex-hole head) with 4 mm and 2.5 mm allen wrenches, respectively; remove the spacer, and clean the restriction with a 0.3 mm wire.

Be sure to insert the bias spring when assembling the pilot relay.

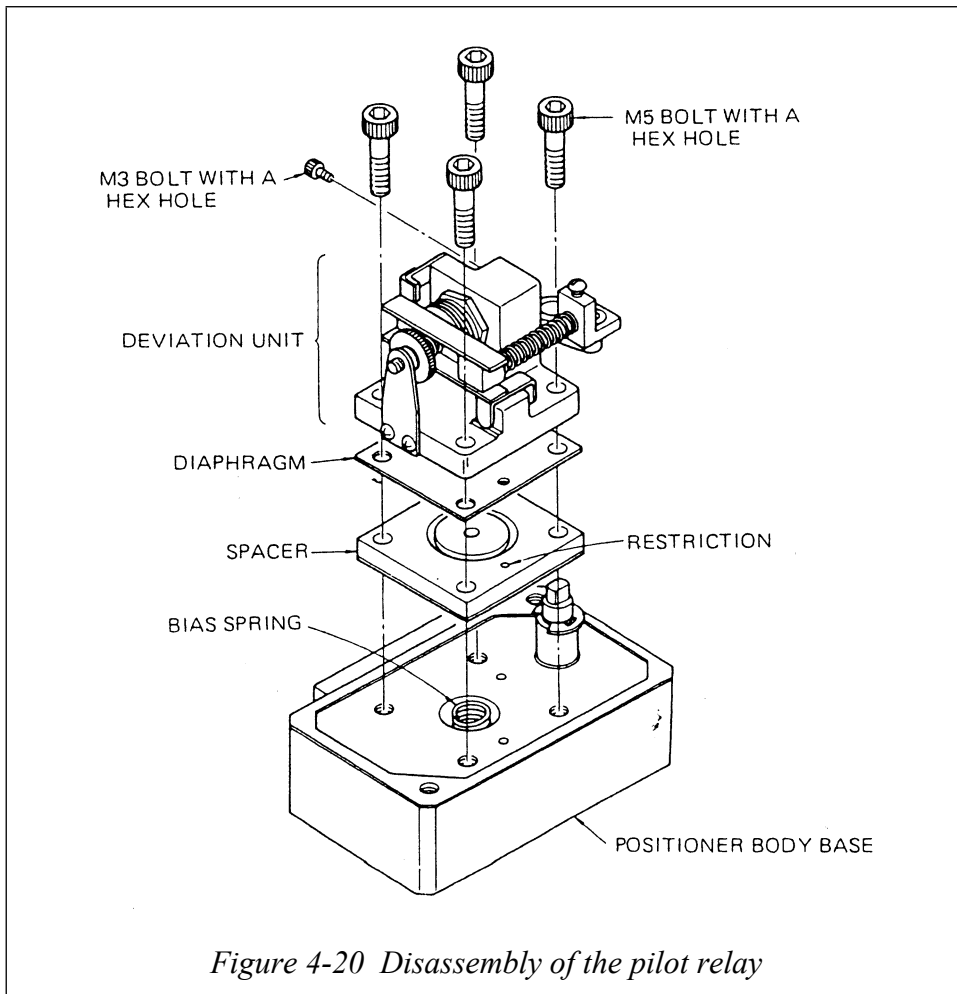

Figure 4-20 Disassembly of the pilot relay

## 4-2-8 : Troubleshooting

Symptom	Cause	Action to take
No output	1. Incorrect adjustment	1. Refer to subsection “4-2-6 : Adjusting the positioner” on page 4-10
	2. Incorrect supply air pressure setting	2. Refer to subsection “4-2-6 : Adjusting the positioner” on page 4-10
	3. Clogged restriction	3. Refer to subsection “Cleaning the restriction” on page 4-11
	4. Incorrect mounting of cam	4. Refer to subsection “4-2-5 : Removing and installing the positioner” on page 4-7
	5. Defective bellows	5. See note.
Output pressure does not decrease	1. Incorrect adjustment	1. Refer to subsection “4-2-6 : Adjusting the positioner” on page 4-10
	2. Clogged restriction	2. See note.
	3. Bias spring	3. Refer to subsection “Cleaning the restriction” on page 4-11
	4. Bypass cock	4. Switch bypass cock to “ON”
	5. Incorrect mounting of cam	5. Refer to subsection “4-2-5 : Removing and installing the positioner” on page 4-7
Unsatisfactory linearity	1. In correct adjustment	1. Refer to subsection “4-2-6 : Adjusting the positioner” on page 4-10
	2. Incorrect mounting of cam	2. Refer to subsection “4-2-5 : Removing and installing the positioner” on page 4-7
Large hysteresis	1. Loose bolts or nuts	1. Tighten the loose bolts or nuts
	2. Defective bellows	2. See note.
Sluggish action	1. Bypass cock	1. Switch bypass cock “ON”
	2. Clogged restriction of bellows	2. See note.
Hunting occurs	1. Fiction in valve body or actuator	1. Inspect the valve body and actuator

**~Note** *The deviation unit requires to be disassembled. Disassembly should desirably be done by an Azbil Corporation service agent. Disassembly by the customer is not recommended.*





# Chapter 5 : Changing the mounting attitude of actuator and type of valve action

The mounting attitude of the model VFR valves actuator can be changed and the type of its action can be modified without requiring any additional parts.

## 5-1 : Changing the mounting attitude of actuator

The actuator can be installed in any one of the four attitudes shown in Figure 5-1. The standard mounting attitudes are positions 1 and 5 shown in Figure 5-1. If the actuator is to be installed in an attitude other than the standard attitudes, take precautions not to let water get into and entrapped inside the actuator.

- (1) Remove the actuator from the valve body by following the steps described in “Chapter 3 : Actuator”.
- (2) While securely holding the actuator, remove the mounting-bolts of the yoke and bracket. (See Figure 3-1.) Set the actuator to the desired attitude and fix the yoke and bracket with the mounting-bolts.
- (3) Fix the actuator to the valve body by following, in the reverse order, the procedures in Step (1) above. Make certain that the roller of the clamp is correctly set on the hand-wheel shaft.
- (4) Adjust the actuator by referring to subsection “3-2 : Adjusting the actuator”. For the positioner, refer to subsection “4-2-6 : Adjusting the positioner”.

## 5-2 : Changing the valve action

- (1) Flatten the anti-rotation fitting of the lock nut of the fork. (See Figure 3-4.)
- (2) Remove the bolts (hex-hole head) from the clamp and remove the clamp from the valve stem. (See Figure 3-4.)
- (3) Change the poisoning of the clamp and fork by referring to Figure 3-9.
- (4) Remove the connecting-bolts from the intermediate bracket and main bracket, and change their positioning as shown in Figure 5-3.
- (5) Flip over the direction indicator plate of the handwheel. Make certain that the plate indicates the correct directions for the direct action or the reverse action. (See Figure 5-4.)
- (6) For assembly, follow the above disassembly procedure in the reverse order.

When valve actions are changed between direct action and reverse action, the position of the air piping connection port also is changed. Remove the diaphragm case (top) once and change their position as required.

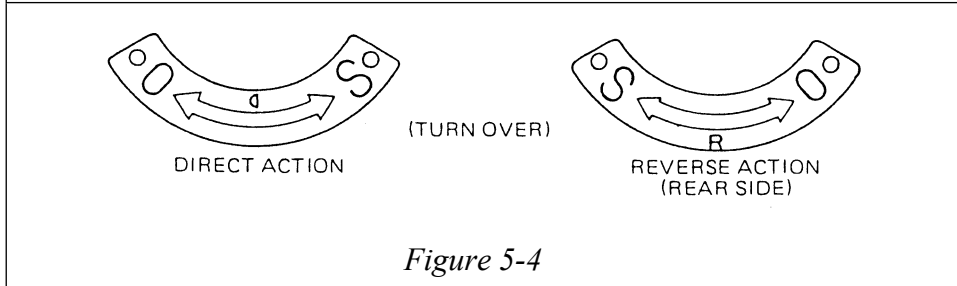
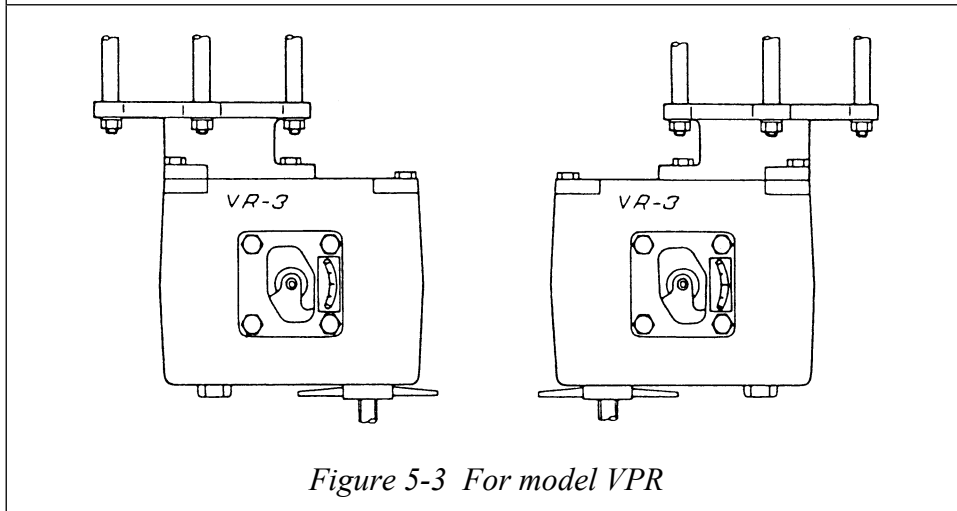
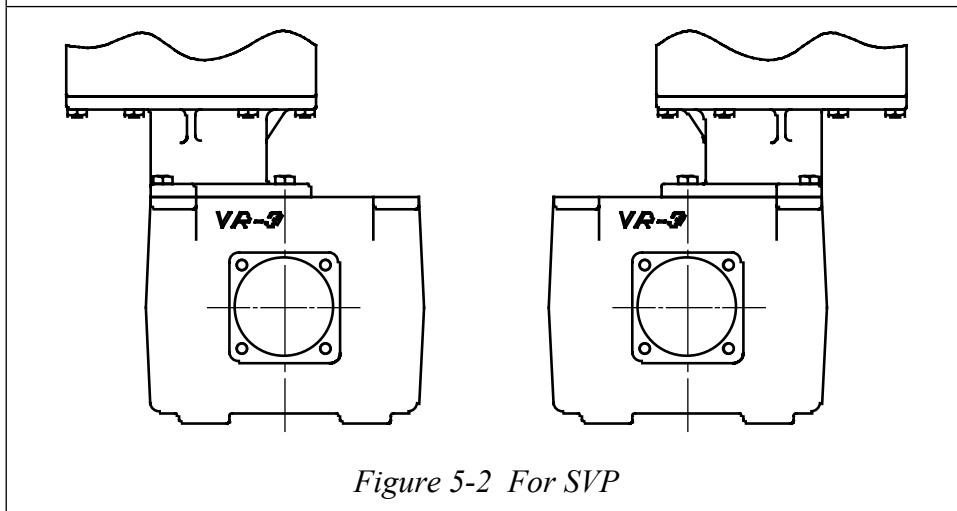
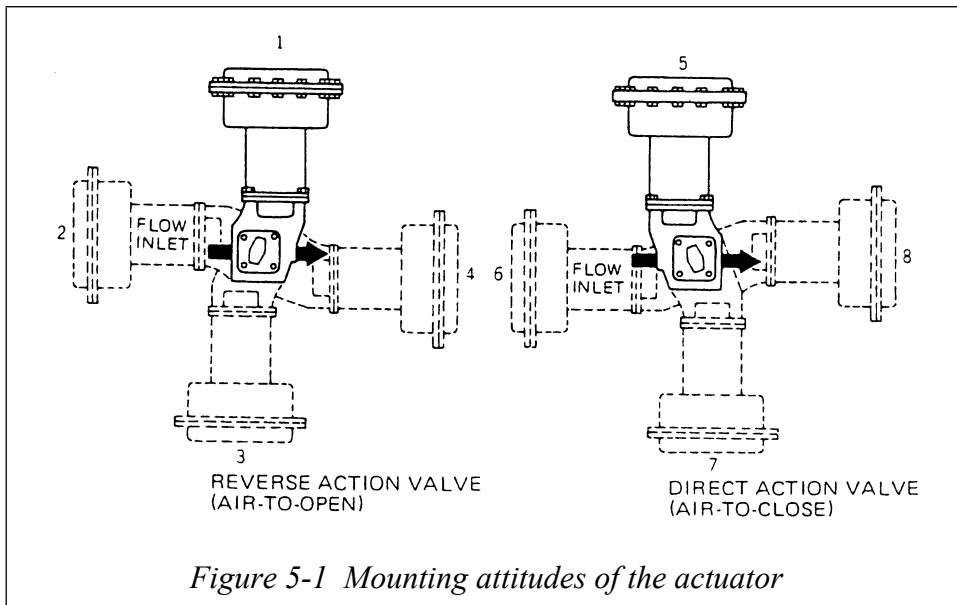



# Terms and Conditions

We would like to express our appreciation for your purchase and use of Azbil Corporation's products. You are required to acknowledge and agree upon the following terms and conditions for your purchase of Azbil Corporation's products (system products, field instruments, control valves, and control products), unless otherwise stated in any separate document, including, without limitation, estimation sheets, written agreements, catalogs, specifications and instruction manuals.

## 1. Warranty period and warranty scope

### 1.1 Warranty period

Azbil Corporation's products shall be warranted for one (1) year from the date of your purchase of the said products or the delivery of the said products to a place designated by you.

### 1.2 Warranty scope

In the event that Azbil Corporation's product has any failure attributable to azbil during the aforementioned warranty period, Azbil Corporation shall, without charge, deliver a replacement for the said product to the place where you purchased, or repair the said product and deliver it to the aforementioned place. Notwithstanding the foregoing, any failure falling under one of the following shall not be covered under this warranty:

- (1) Failure caused by your improper use of azbil product (noncompliance with conditions, environment of use, precautions, etc. set forth in catalogs, specifications, instruction manuals, etc.);
- (2) Failure caused for other reasons than Azbil Corporation's product;
- (3) Failure caused by any modification or repair made by any person other than Azbil Corporation or Azbil Corporation's subcontractors;
- (4) Failure caused by your use of Azbil Corporation's product in a manner not conforming to the intended usage of that product;
- (5) Failure that the state-of-the-art at the time of Azbil Corporation's shipment did not allow Azbil Corporation to predict; or
- (6) Failure that arose from any reason not attributable to Azbil Corporation, including, without limitation, acts of God, disasters, and actions taken by a third party.

Please note that the term "warranty" as used herein refers to equipment-only-warranty, and Azbil Corporation shall not be liable for any damages, including direct, indirect, special, incidental or consequential damages in connection with or arising out of Azbil Corporation's products.

## 2. Ascertainment of suitability

You are required to ascertain the suitability of Azbil Corporation's product in case of your use of the same with your machinery, equipment, etc. (hereinafter referred to as "Equipment") on your own responsibility, taking the following matters into consideration:

- (1) Regulations and standards or laws that your Equipment is to comply with.
- (2) Examples of application described in any documents provided by Azbil Corporation are for your reference purpose only, and you are required to check the functions and safety of your Equipment prior to your use.
- (3) Measures to be taken to secure the required level of the reliability and safety of your Equipment in your use

Although azbil is constantly making efforts to improve the quality and reliability of Azbil Corporation's products, there exists a possibility that parts and machinery may break down.

You are required to provide your Equipment with safety design such as fool-proof design, \*1 and fail-safe design\*2 (anti-flame propagation design, etc.), whereby preventing any occurrence of physical injuries, fires, significant damage, and so forth. Furthermore, fault avoidance,\*3 fault tolerance,\*4 or the like should be incorporated so that the said Equipment can satisfy the level of reliability and safety required for your use.

\*1. A design that is safe even if the user makes an error.

\*2. A design that is safe even if the device fails.

\*3. Avoidance of device failure by using highly reliable components, etc.

\*4. The use of redundancy.

## 3. Precautions and restrictions on application

Azbil Corporation's products other than those explicitly specified as applicable (e.g. azbil Limit Switch For Nuclear Energy) shall not be used in a nuclear energy controlled area (radiation controlled area).

Any Azbil Corporation's products shall not be used for/with medical equipment.

The products are for industrial use. Do not allow general consumers to install or use any Azbil Corporation's product.

However, azbil products can be incorporated into products used by general consumers. If you intend to use a product for that purpose, please contact one of our sales representatives.

In addition,

you are required to conduct a consultation with our sales representative and understand detail specifications, cautions for operation, and so forth by reference to catalogs, specifications, instruction manual, etc. in case that you intend to use azbil product for any purposes specified in (1) through (6) below.

Moreover, you are required to provide your Equipment with fool-proof design, fail-safe design, anti-flame propagation design, fault avoidance, fault tolerance, and other kinds of protection/safety circuit design on your own responsibility to ensure reliability and safety, whereby preventing problems caused by failure or nonconformity.

- (1) For use under such conditions or in such environments as not stated in technical documents, including catalogs, specification, and instruction manuals

- (2) For use of specific purposes, such as:
  - \* Nuclear energy/radiation related facilities  
[For use outside nuclear energy controlled areas] [For use of Azbil Corporation's Limit Switch For Nuclear Energy]
  - \* Machinery or equipment for space/sea bottom
  - \* Transportation equipment  
[Railway, aircraft, vessels, vehicle equipment, etc.]
  - \* Antidisaster/crime-prevention equipment
  - \* Burning appliances
  - \* Electrothermal equipment
  - \* Amusement facilities
  - \* Facilities/applications associated directly with billing
- (3) Supply systems such as electricity/gas/water supply systems, large-scale communication systems, and traffic/air traffic control systems requiring high reliability
- (4) Facilities that are to comply with regulations of governmental/public agencies or specific industries
- (5) Machinery or equipment that may affect human lives, human bodies or properties
- (6) Other machinery or equipment equivalent to those set forth in items (1) to (5) above which require high reliability and safety

#### 4. Precautions against long-term use

Use of Azbil Corporation's products, including switches, which contain electronic components, over a prolonged period may degrade insulation or increase contact-resistance and may result in heat generation or any other similar problem causing such product or switch to develop safety hazards such as smoking, ignition, and electrification. Although acceleration of the above situation varies depending on the conditions or environment of use of the products, you are required not to use any Azbil Corporation's products for a period exceeding ten (10) years unless otherwise stated in specifications or instruction manuals.

#### 5. Recommendation for renewal

Mechanical components, such as relays and switches, used for Azbil Corporation's products will reach the end of their life due to wear by repetitious open/close operations. In addition, electronic components such as electrolytic capacitors will reach the end of their life due to aged deterioration based on the conditions or environment in which such electronic components are used. Although acceleration of the above situation varies depending on the conditions or environment of use, the number of open/close operations of relays, etc. as prescribed in specifications or instruction manuals, or depending on the design margin of your machine or equipment, you are required to renew any Azbil Corporation's products every 5 to 10 years unless otherwise specified in specifications or instruction manuals. System products, field instruments (sensors such as pressure/flow/level sensors, regulating valves, etc.) will reach the end of their life due to aged deterioration of parts. For those parts that will reach the end of their life due to aged deterioration, recommended replacement cycles are prescribed. You are required to replace parts based on such recommended replacement cycles.

#### 6. Other precautions

Prior to your use of Azbil Corporation's products, you are required to understand and comply with specifications (e.g., conditions and environment of use), precautions, warnings/cautions/notices as set forth in the technical documents prepared for individual Azbil Corporation's products, such as catalogs, specifications, and instruction manuals to ensure the quality, reliability, and safety of those products.

#### 7. Changes to specifications

Please note that the descriptions contained in any documents provided by azbil are subject to change without notice for improvement or for any other reason. For inquires or information on specifications as you may need to check, please contact our branch offices or sales offices, or your local sales agents.

#### 8. Discontinuance of the supply of products/parts

Please note that the production of any Azbil Corporation's product may be discontinued without notice. For repairable products, we will, in principle, undertake repairs for five (5) years after the discontinuance of those products. In some cases, however, we cannot undertake such repairs for reasons, such as the absence of repair parts. For system products, field instruments, we may not be able to undertake parts replacement for similar reasons.

#### 9. Scope of services

Prices of Azbil Corporation's products do not include any charges for services such as engineer dispatch service. Accordingly, a separate fee will be charged in any of the following cases:

- (1) Installation, adjustment, guidance, and attendance at a test run
- (2) Maintenance, inspection, adjustment, and repair
- (3) Technical guidance and technical education
- (4) Special test or special inspection of a product under the conditions specified by you

Please note that we cannot provide any services as set forth above in a nuclear energy controlled area (radiation controlled area) or at a place where the level of exposure to radiation is equivalent to that in a nuclear energy controlled area.

AAS-511A-014-09



---

<b>Document Number:</b>	OM2-8130-0200
<b>Document Name:</b>	FloWing Eccentric Rotary type Control Valves Model: VFR (6 in. or more) User's Manual
<b>Date:</b>	7th edition: Apr. 2023
<b>Issued/Edited by:</b>	Azbil Corporation

---

Azbil Corporation