

# Control Valve

Model HCB\_\_\_/HCU\_\_\_/HCN\_\_\_/HPC\_\_\_

## User's Manual

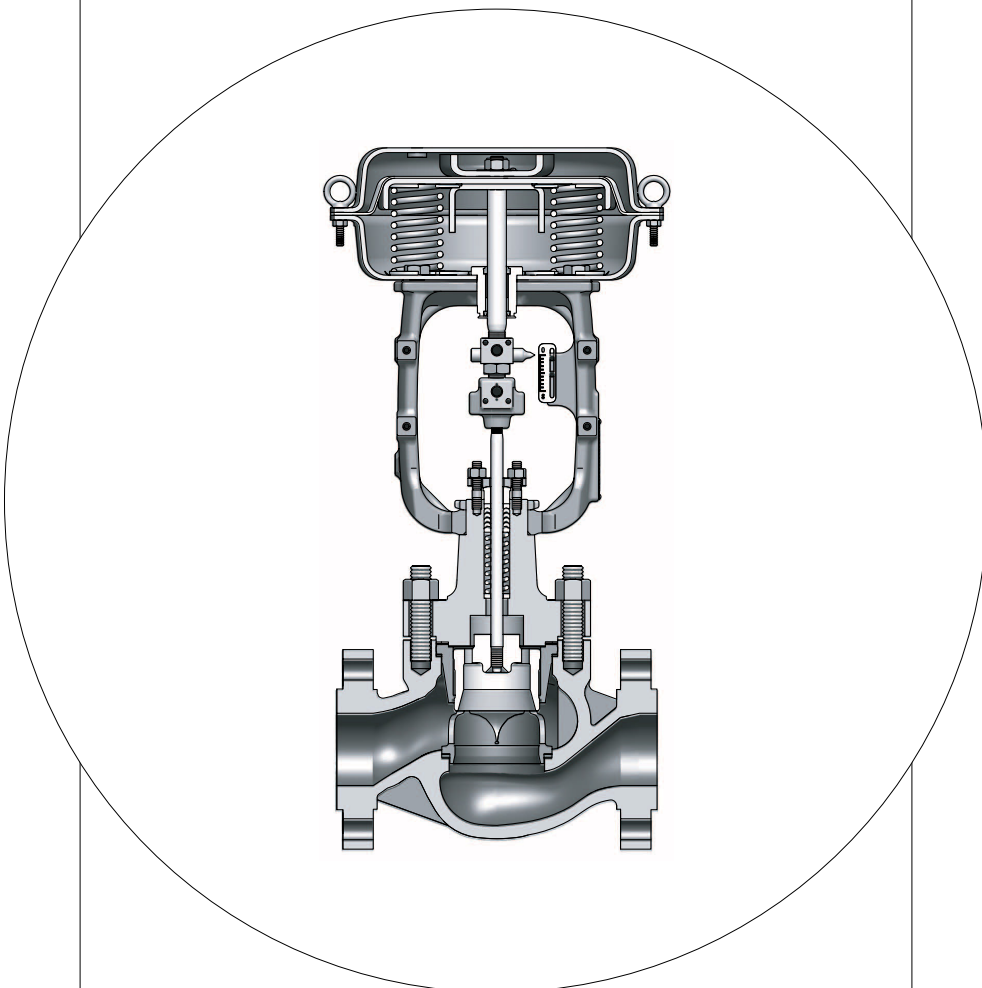

Azbil Corporation

## **NOTICE**

---

While this information is presented in good faith and believed to be accurate, Azbil Corporation disclaims the implied warranties of merchantability and fitness for a particular purpose and makes no express warranties except as may be stated in its written agreement with and for its customer.

In no event is Azbil Corporation liable to anyone for any indirect, special or consequential damages, The information and specifications in this document are subject to change without notice.

# Table of Contents

Chapter 1. General .....	1-1
1-1. Scope .....	1-1
1-2. Major components of control valves .....	1-1
1-3. Structures .....	1-2
1-4. Nameplate .....	1-3
Chapter 2. Installation .....	2-1
2-1. Maximum lifting loads of eyebolts .....	2-1
2-2. Installing valve in process pipe .....	2-1
2-3. Item to be checked after installation and before starting operation .....	2-2
Chapter 3. Inspection and Maintenance .....	3-1
Chapter 4. Disassembly and Assembly .....	4-1
4-1. Detaching actuator from valve body .....	4-1
4-2. Disassembly and assembly of valve body .....	4-1
4-3. Disassembly and assembly of actuator .....	4-7
4-4. Disassembly and assembly of model PSA 1 .....	4-8
4-5. Disassembly and assembly of model HA2, HA3, or HA4 actuator .....	4-14
4-6. Disassembly and assembly of model PSA6 actuator .....	4-20
4-7. Disassembly and assembly actuator .....	4-23
Chapter 5. Adjustment .....	5-1
Chapter 6. Direct/Reverse Action Type Conversion and Spring Range Change of Actuator .....	6-1
6-1. Direct/Reverse action change .....	6-1
6-2. Stroke and range spring change .....	6-5
Chapter 7. Instructions for Top Handwheel of Actuator .....	7-1
7-1. Model PSA1 actuator .....	7-1
7-1-1. Operating instructions .....	7-1
7-1-2. Disassembly and assembly of top handwheel .....	7-3
7-2. Model HA2, HA3, or HA4 actuator .....	7-5
7-2-1. Operating instructions .....	7-5
7-2-2. Disassembly and assembly of top handwheel .....	7-10
Chapter 8. Instructions for Side Handwheel of Actuator .....	8-1
8-1. Installation procedure .....	8-1
8-2. Operating instructions .....	8-1
8-3. Disassembly of side assembly of side handwheel .....	8-2

Chapter 9. Instructlons for Bellows Sealed Type of Control Valves.....	9-1
9-1. Structures (Model HCB Control Valves) .....	9-2
9-2. Disassembly and assembly.....	9-3
 Chapter 10. Azbil Low Emission standard-compliant gland packing .....	10-1
10-1. Overview.....	10-1
10-2. Structure .....	10-1
10-3. Installation into the gland .....	10-2
10-3-1. Preparation for installation .....	10-2
10-3-2. Start of installation .....	10-3
10-3-3. Retightening.....	10-6
10-4. Parts List .....	10-7
 Chapter 11. Certified ISO 15848-1 compliant low emission gland packing .....	11-1
11-1. Overview.....	11-1
11-2. Structure .....	11-2
11-3. Starting Operation.....	11-2
11-4. Assembling the parts of the gland.....	11-3
11-4-1. Preparation for assembly .....	11-3
11-4-2. Assembly.....	11-5
11-5. Parts List .....	11-9
11-6. Application to existing control valves .....	11-13
11-7. Disposal.....	11-13
 Chapter 12. Troubleshooting.....	12-1
 Chapter 13. Recommended Spare Parts .....	13-1

# Chapter 1. General

## 1-1. Scope

This manual covers the instructions for the following Control Valves:

- Model HCB : Pressure-Balanced Cage-Type control valves
- Model HCU : Pressure-Unbalance Cage-Type control valves
- Model HCN : Low-Noise Cage-Type control valve
- Model HPC : Pressure-Balanced High-Pressure Cage-Type control valve

For the valve positioners, refer the following operators manuals.

- Model VPE OM2-8310-0410 Pneumatic valve positioner for small actuators
- Model HTP OM2-83 10-0200 Pneumatic valve positioner (Single Acting type)
- Model HEP 15, 16, 17 OM2-8313-0100 Electro-Pneumatic Valve Positioner (Single Acting Type)
- Model AVP 300/301/302/200/201/202  
CM2-AVP300-2001 Electro-pneumatic positioner
- Model AVP 303/203 CM2-AVP303-2001 Electro-pneumatic positioner
- Model AVP701/702 CM2-AVP702-2001 Smart valve positioner 700 series (HART)
- Model AVP703 CM2-AVP703-2001 Smart valve positioner 700 series (FOUNDATION Fieldbus)

## 1-2. Major components of control valves

Each control valve is comprised of two major components, namely, a valve body and an actuator. Various combinations of valve body and actuator are available to meet various type of uses with different valve sizes, pressure ratings, types of connections, types of materials, and actuator sizes.

(For details of specifications, refer to Specification Sheets SS2-8113-1100, -1120, and -1200.)

### 1-3. Structures

The structures of typical control valves are shown in Figure 1-1 through 1-4.

The valve body is connected to the bonnet with stud bolts and nuts. A gasket is (two gaskets are) provided at the connection section to seal against the internal fluid or to let the valve body make up a pressure vessel. The valve plug is supported by the guide ring and cage, and driven by the actuator. The actuator has multiple springs and a diaphragm, and converts the pneumatic control signal into a mechanical (positional) control signal with which to position the valve plug.

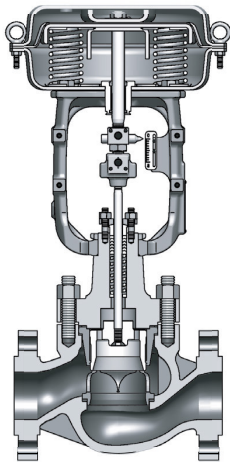

Figure 1-1 Pressure-Balanced Cage-Type Control Valve Model HCB

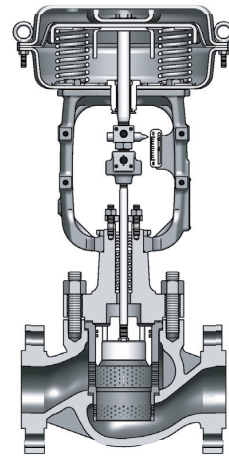

Figure 1-2 Pressure-Unbalanced Cage-Type Control Valve Model HCU

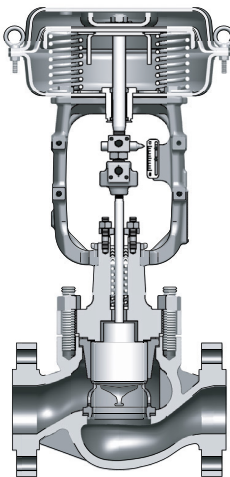

Figure 1-3 Low-Noise Cage-Type Control Valve Model HCN

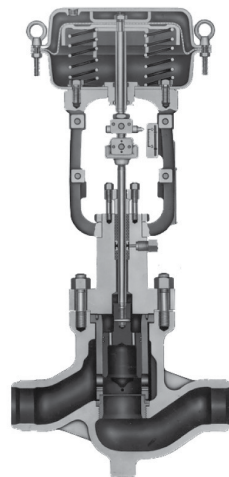

Figure 1-4 Pressure-Balanced High-Pressure Cage-Type Control Valve Model HPC

## 1-4. Nameplate

A nameplate as shown in Figure 1-5 is posted on each control valve. The nameplate indicates the model number, valve size, pressure rating, trim material, date of manufacture and other major specifications of the control valve. Before installing the control valve, make sure that the specifications indicated on the nameplate conform with the conditions of use. The nameplate indicate also the product number (PROD.NO.) of the control valve. Please mention this number also when consulting your Azbil Corporation agent for replacement of parts or other modification of the control valve.

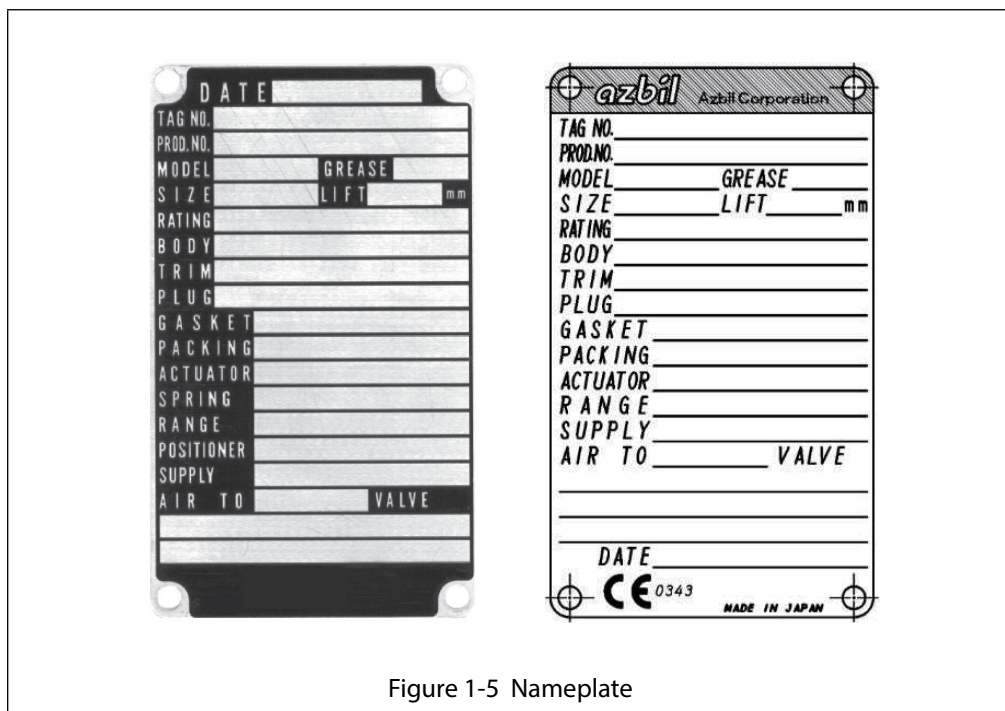

Figure 1-5 Nameplate

## **Compliance with Regulations**

This product complies with the directive below.

- Pressure Equipment Directive (PED) 2014/63/EU

## **Requirements for workers (installation, operation, maintenance)**

To ensure safety, only specialists who are skilled in instrumentation work should carry out the installation, operation, and maintenance of this device.



# Chapter 2. Installation

## 2-1. Maximum lifting loads of eyebolts

The diaphragm case has a pair of lifting eyebolts. These eyebolts primarily are for lifting the actuator alone. When using the eyebolts for other purposes (such as lifting an actuator bed to its valve body or other components), note that the allowable maximum lifting loads of the eyebolts are as shown in the following table.

Table 2-1 Maximum Lifting Loads of Eyebolts

Actuator model No.	Allowable Maximum Lifting Load of Eyebolts	Weight of Actuator Alone
PSA1	160 kg	8 kg
HA2	160 kg	16 kg
HA3	160 kg	32 kg
HA4	220 kg	68 kg

Note: The eyebolts may be used to lift the actuator together with its valve buy (castglobe valve) of up to pressure rating “Class 600”. When doing this, be extremely careful so that no shock or other abnormal force is applied to the actuator or the valve body.

## 2-2. Installing valve in process pipe

- (1) Before installing the valve in the process pipe, remove foreign matter (such as scales and welding chips) from both upstream and downstream sides of the process pipe.
- (2) Confirm that the direction of process fluid flow conforms with that of the arrowhead mark provided on the valve body.
- (3) Pay attention so that the pipe connection gaskets do not extrude into the process pipe inside. Be sure to use gaskets made of material which is suitable for the process fluid. The welding type of valve employ no gaskets.
- (4) Pay attention so that no excessively large stress is conveyed from the process pipe to the valve body. Uniformly tighten the bolts of the process pipe connection flange. The high pressure type of valves have no flanges, since they are connected to the process by welding.
- (5) Before connecting the air pipes to the actuator and positioner, blow the pipes to clean them.
- (6) Do not install any heating or cooling provisions on the bonnet.

## 2-3. Item to be checked after installation and before starting operation

- (1) Check that there is no leak from air piping.
- (2) Check that the bolts and nuts of the diaphragm case are not loose. Standard tightening torques are as follows:
- (3) Tighten the packing flange nuts to prevent leak from the gland packing section. Standard tightening torques are as shown in Table 2-2.

Table 2-2 Tightening Torques of Packing Flange Nuts

Valve Stem Diameter (mm)	V PTFE Packing	PTFE Yarn Packing (P4519)	Expanded graphite Packing [ P6610CH + P6528 P6610CH + M8590 T2200 + P6710CH (Type2) ]	V PTFE + PTFE Yarn Packing [ PTFE + V7233 PTFE + TK2006 ]
10	1 {8}	9 {90}	5 {50}	3 {30}
13		15 {150}	8 {80}	5 {50}
16		24 {240}	13 {130}	8 {80}
20		32 {320}	18 {180}	10 {100}
25		-	28 {280}	15 {150}
30		66 {660}	36 {360}	20 {200}

Note: The tightening torques mentioned in the above are only to give you reference values.  
Note that tightening torques may vary depending on the type of packing.

Table 2-3 Tightening Torques of packing Flange Nuts for PTFE yarn (Certified ISO 15848-1-compliant low-emission gland packing)

Model	Actuator model	Stem size	Tightening torque
HCB,HCN	HA2	φ 10 mm	12 N·m
	HA3	φ 13 mm	20 N·m
	HA3	φ 16 mm	33 N·m
	HA4	φ 20 mm	44 N·m
	PSA6	φ 30 mm	54 N·m

Table 2-4 Tightening Torques of packing Flange Nuts for expanded graphite (Certified ISO 15848-1-compliant low-emission gland packing)

Model	Actuator model	Stem size	Tightening torque
HCB,HCN	HA2	φ 10 mm	12 → 0 (loosening) → 8 N·m
	HA3	φ 13 mm	20 → 0 (loosening) → 13N·m
	HA3	φ 16 mm	33 → 0 (loosening) → 22N·m
	HA4	φ 20 mm	44 → 0 (loosening) → 30N·m
	PSA6	φ 30 mm	54 → 0 (loosening) → 36N·m

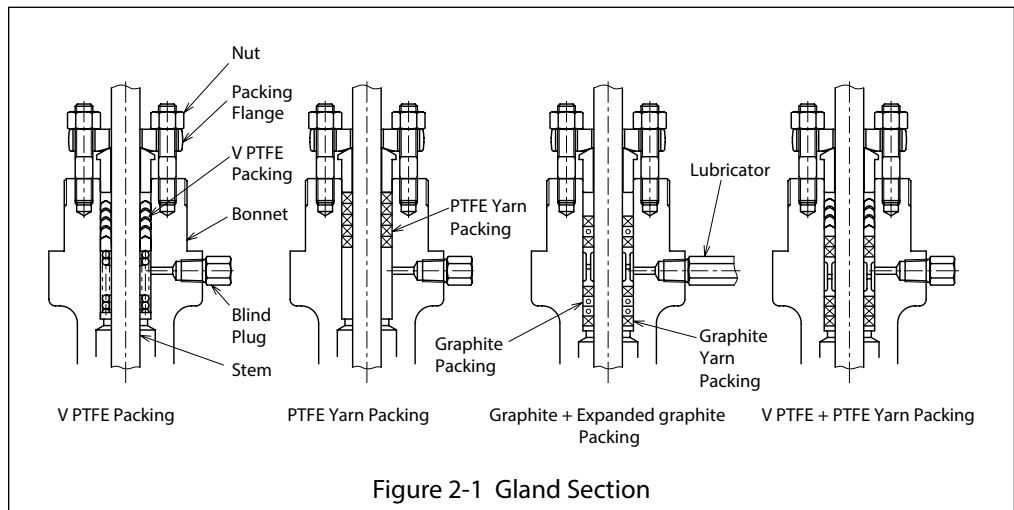
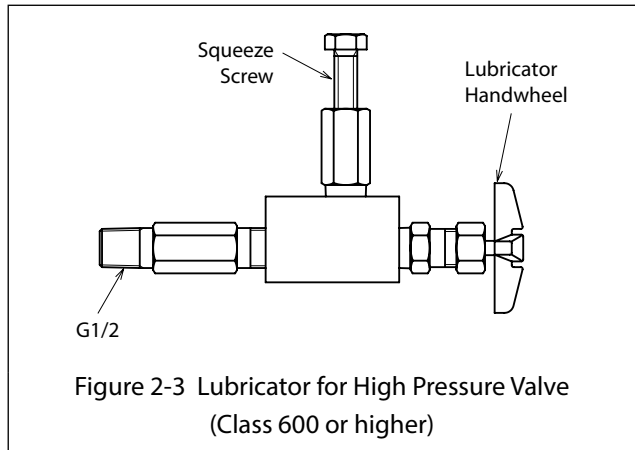
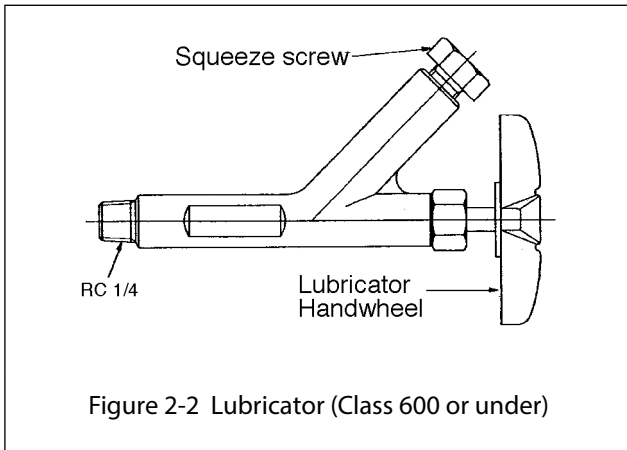

Figure 2-1 Gland Section

- (4) If the valve is provided with a lubricator as shown in Figure 2-2, check whether the bonnet section has been lubricated or not. To do this, loosen the lubricator handwheel and turn the squeeze screw. If the squeeze screw turn lightly, and grease in the lubricating procedure mentioned below. (If the squeeze screw turns heavily, this means that grease has been applied.)



### Lubricating Procedure

- (a) prepare grease of the type indicated on the nameplate.
  - (b) Tightly close the lubricator handwheel.
  - (c) Remove the squeeze screw, apply grease, and set the squeeze screw.
  - (d) Loosen the lubricator handwheel and drive grease by turning the squeeze screw.
  - (e) Repeat the procedure of (b), (c) and (d) until turning of the squeeze screw becomes heavier. Tightly close lubricator handwheel.
- (5) Pressurizing valve, check that there is no leak from the gasket sections for connection to the valve body and process pipe. If leak is found, tighten the nuts. (Especially when the process fluid temperature is 400 or higher, tighten the nuts again after raising temperature of the valve in order that it may serve for a longer period without requiring immediate maintenance service.) Standard tightening torques are shown in Tables 2-2 of Chapter 2, Table 4-3 of Chapter 4.
  - (6) When raising temperature of a valve which is used for high temperature service, raise temperature gradually (standard rate is 100 per hour) and do not operate the valve when its temperature is being raised.

## Chapter 3. Inspection and Maintenance

### **Inspect and service the actuator as follows:**

- (1) Tightening the gland:  
Tighten the gland once in every 6 months or thereabout. The tightening procedure is as given in Section 2-3-(3).
- (2) Lubricating the gland:  
Lubricating the gland once in every 6 months or thereabout. The lubricating procedure is as given in Section 2-3-(4).
- (3) Check for hunting of valve Position:  
Refer to Chapter 12. Troubleshooting.
- (4) Check for abnormal noise and vibration:  
Refer to Chapter 12. Troubleshooting.



# Chapter 4. Disassembly and Assembly

This chapter covers the disassembly and assembly procedures of the actuator for its overhaul or modification.

## 4-1. Detaching actuator from valve body

See Figure 4-3.

- (1) Apply to the actuator an air pressure so that the valve position pointer is at a point of 10% - 20% above the fully closed point.
- (2) Loosen the clamping-bolts of the stem connector, remove the stem connector, and detach the actuator stem from the valve stem.
- (3) Remove the clamping-nut of the yoke.
- (4) Raise the actuator to detach it from the valve body.

Precautions: For detaching the actuator from the valve body which is kept installed in the process pipe, be sure to shut down the process for and release the process pressure before detaching the actuator.

## 4-2. Disassembly and assembly of valve body

To disassemble or assemble the valve body, refer to Figure 4-1-1 through Figure 4-2 and proceed as described below.

(For handling of the bellows sealed type (optional type) of valves, see Chapter 9.)

### Disassembly Procedure

- (1) Loosen the hex nuts of the packing flange.
- (2) Remove the hex nuts (1) of the bonnet (extension bonnet).
- (3) Raise and detach the bonnet from the valve body.

Precautions: If the valve plug comes out together with the bonnet, remove the plug from the bonnet by rotating the plug. When doing this, exercise care not to damage the valve stem.

### Inspection

Inspect the disassembled parts for damage. If any damage is found, replace the parts.

(When ordering parts, mention also the Prod. No. of the valve which is indicated on the nameplate.)

- (1) Do not re-use the removed gland packing. Use fresh packing when assembling the valve.
- (2) Check that the seating surfaces of plug and seat ring are not damaged.
- (3) Check that the gasket-contacting surfaces of valve body, bonnet and guide ring are not damaged. Do not re-use the removed gasket. Use fresh gasket when assembling the valve.
- (4) Check that the plug guide section, the stem, and the internal guiding sections of guide bushing are not damaged..

### Assembly Procedure

- (1) For an integral-type cage valve, put a spiral gasket in the valve body. For a splittype cage valve, securely fix the seated ring into the valve body with threads, using the special tools. (Apply lubricant “Neverseize” to the gasket, except those of the oil-inhibited valves. For the tightening torque of model HPC, see Table 4-1.)
- (2) Put the gasket (2) in the valve body.
- (3) Put the cage in the valve body.
- (4) Put the gasket (1) on the cage.
- (5) Put the bonnet on the valve body and check that the bonnet is correctly, mate with the indented section of the valve body. Tighten the nuts uniformly, paying attention so that they are not tightened unevenly (tighten alternately the ones located at symmetrical positions). For the tightening torque, see Table 4-3.
- (6) Insert the gland packing as shown in Figure 2-1.  
Note: When yarn packing sheets are used, overlap sheets in such manner that their cut ends are positioned alternately.
- (7) Place the packing follower and packing flange, and tighten the nuts.  
For the tightening torques, see Table 2-2.

Table 4-1 Model HPC Seated Ring Tightening Torques

Size (in.)	ANSI Class	Torque (N·m{kgf·cm})
1-1/2	900-2,500	310 {3,100}
2	900-2,500	570 {5,700}
3	900-1,500	1,000 {11,000}
4	900-1,500	1,800 {18,000}
6	900-1,500	3,750 {37,500}
8	900-1,500	5,500 {55,000}
3	2,500	700 {7,000}
4	2,500	1,550 {15,500}
6	2,500	3,000 {30,000}
8	2,500	4,000 {40,000}



Table 4-2 Model HCB/HCU/HCN Seated Ring Tightening Torques

Size (in.)	Torque (N·m{kgf·cm})
3	650 {6,500}
4	800 {8,000}
6	1,200 {12,000}
8	1,500 {15,000}

Table 4-3 Tightening Torques of Bonnet Stud Bolts

Bolt	Torque (N·m{kgf·cm})
M12	60 {600}
M16	100 {1,000}
M20	150 {1,500}
M22	200 {2,000}
M24	250 {2,500}
M27	350 {3,500}
M30	500 {5,000}
M33	660 {6,600}
M36	850 {8,500}
M39	1,000 {10,000}
M42	1,200 {12,000}
M45	1,400 {14,000}

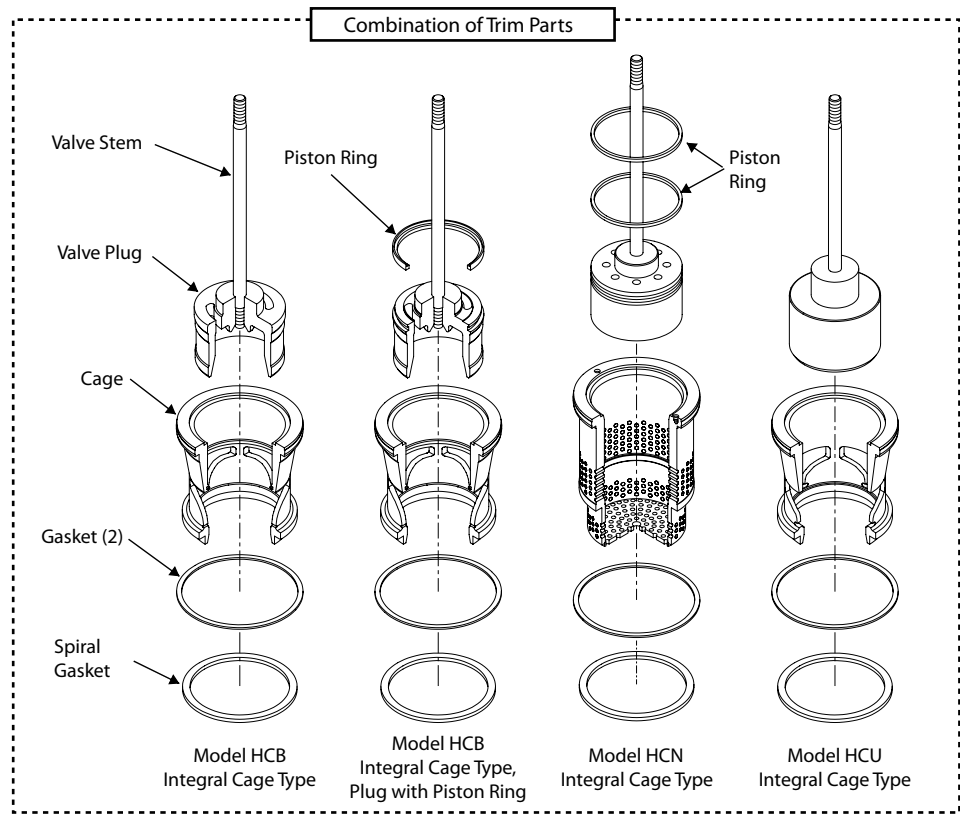
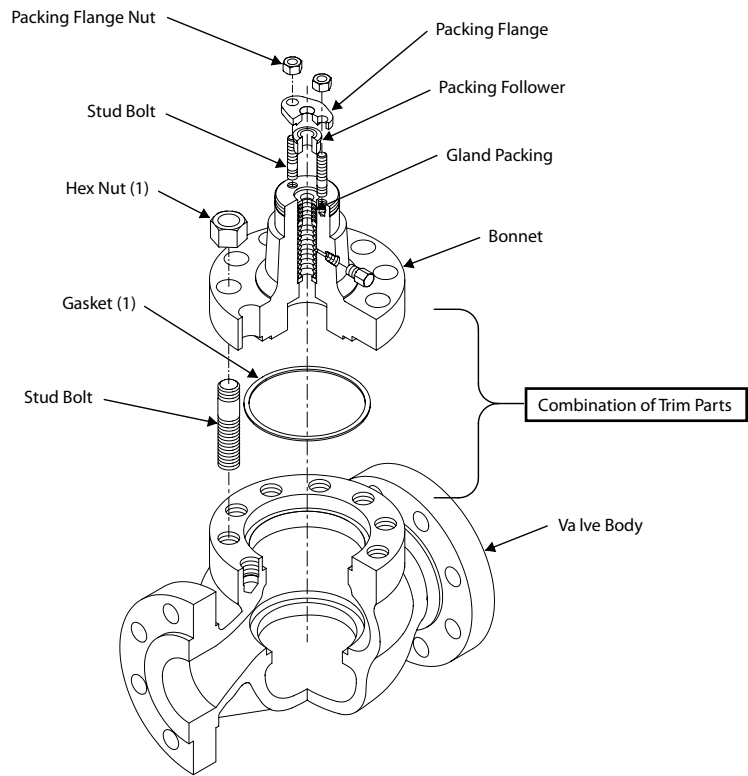

Figure 4-1-1 Normal Temperature Type

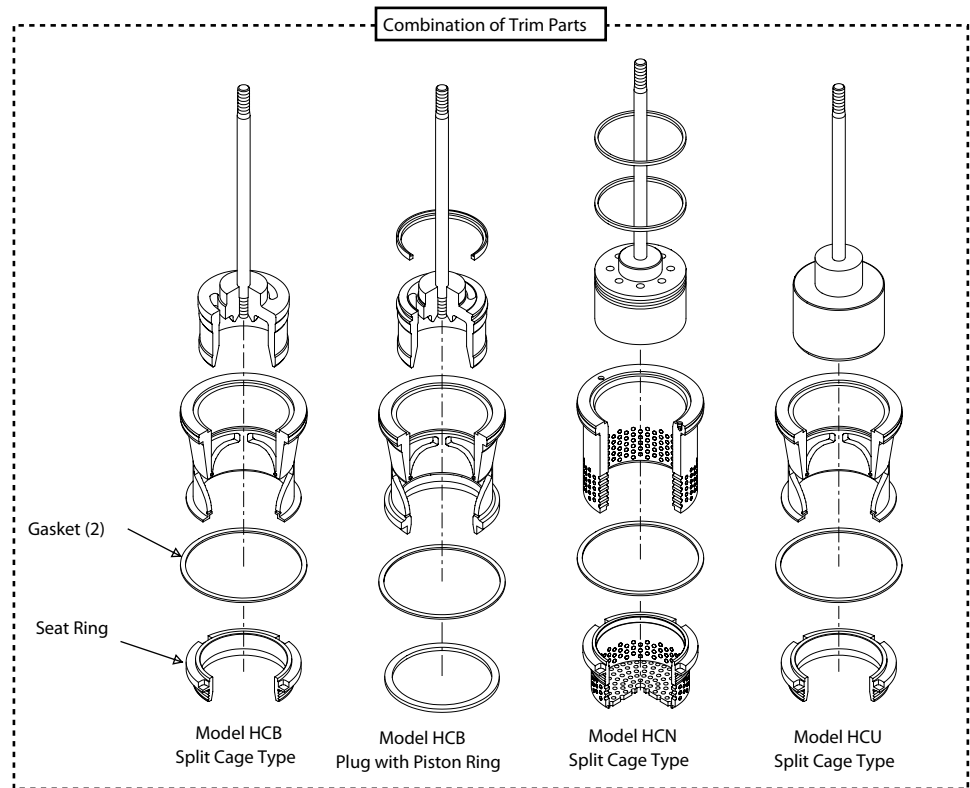
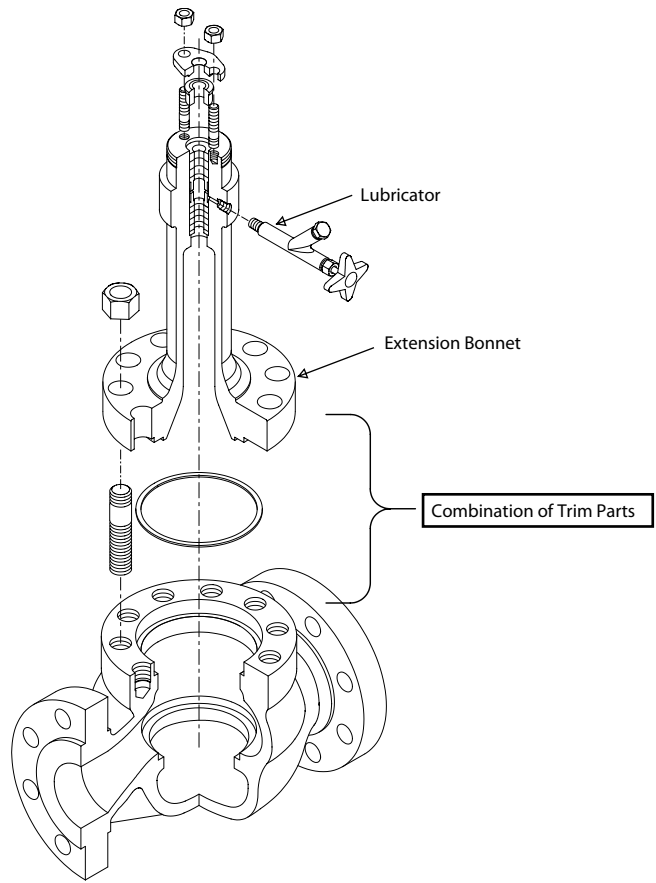

Figure 4-1-2 High Temperature Type (Extended Bonnet Type)

Figure 4-1 Model HCB, HCN, HCU Control Valves

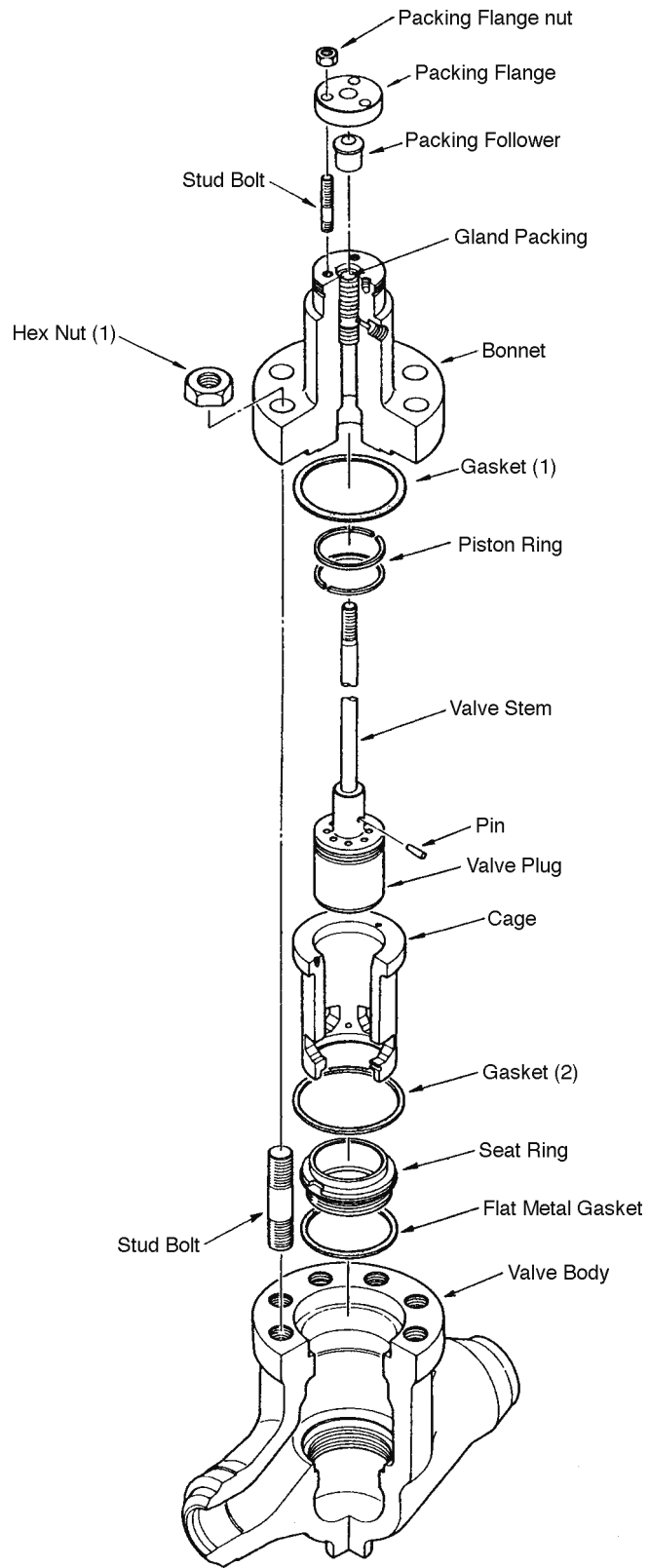

Figure 4-2 Model HPC Control Valves

### 4-3. Disassembly and assembly of actuator

Normally the actuator requires no adjustment. However, it should be disassembled and assembled when installing it on a valve body, when modifying its specifications, or when replacing damaged parts. The disassembly and assembly procedure of the actuator for such purposes are covered in Sections 4-4 and 4-5.

To disassemble the actuator, refer to Figure 4-3 to Figure 4-17.

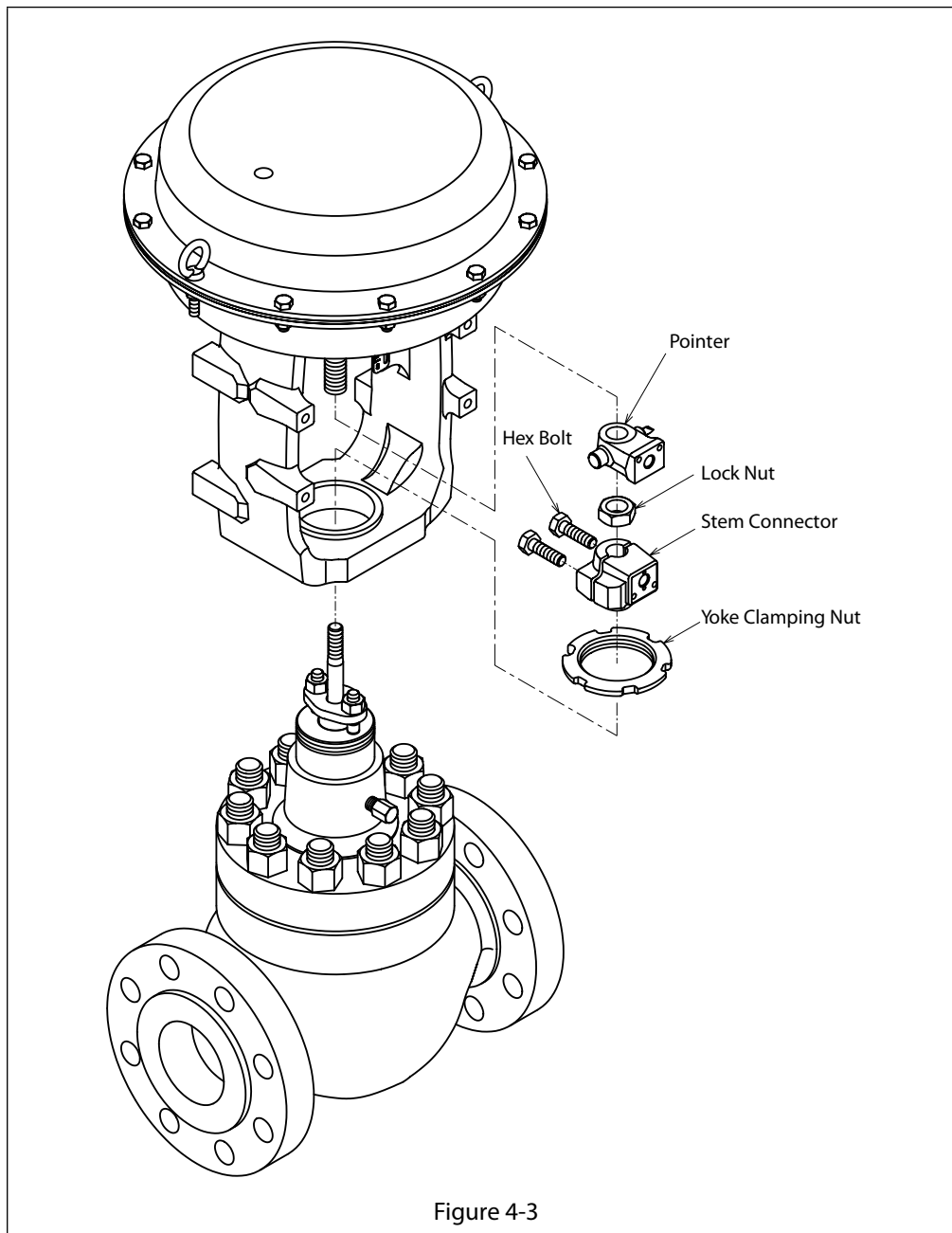



Figure 4-3

When disassembling or assembling the actuator, keep it in the vertical attitude. For the tightening torques of bolts and nuts, see Table 4-4, Table 4-5.

For the names of the parts, see Figure 4-9 and Figure 4-17.

### Notes for Disassembly

- (1) The nuts for the eyebolts are made of stainless steel. Discriminate these nuts from other nuts when assembling the diaphragm case.
- (2) It is recommendable to make locating marks on the top and bottom diaphragm cases before disassembly. This will help you to find easily the air piping connector location.
- (3) Store the removed parts in a clean place.

 <b>CAUTION</b>
Never loosen or remove carelessly the bolts and nuts of the actuator. The actuator employs powerful compressed springs and if you remove the bolts and nuts carelessly, the springs may leap out causing hazards. When removing the bolts and nuts, be sure to observe the instructions given for disassembly and assembly procedures of the actuator and top handwheel.

## 4-4. Disassembly and assembly of model PSA 1

### Disassembly procedure

#### A. Direct action model (see Figure 4-4)

- (1) Disconnect the air piping and detach the accessories from the actuator.
- (2) Remove the stem connector.
- (3) Remove the clamping bolts (except the pair of eyebolts) from the diaphragm case.
- (4) Alternately and evenly loosen the pair of eyebolts. The initial setting of the springs is achieved using these eyebolts.
- (5) Removing the diaphragm case. Pull the actuator rod upward and out together with the diaphragm.
- (6) Take out the springs.

#### B. Reverse action model (see Figure 4-5)

- (1) Disconnect the air piping and detach the accessories from the actuator.
- (2) Remove the stem connector.
- (3) Remove the clamping bolts (except the pair of eyebolts) from the diaphragm case.
- (4) Alternately and evenly loosen the pair of eyebolts. The initial setting of the springs is achieved using the eyebolts.
- (5) Remove the diaphragm case. Take on the springs.
- (6) Pull the actuator rod upward and out together with the diaphragm.

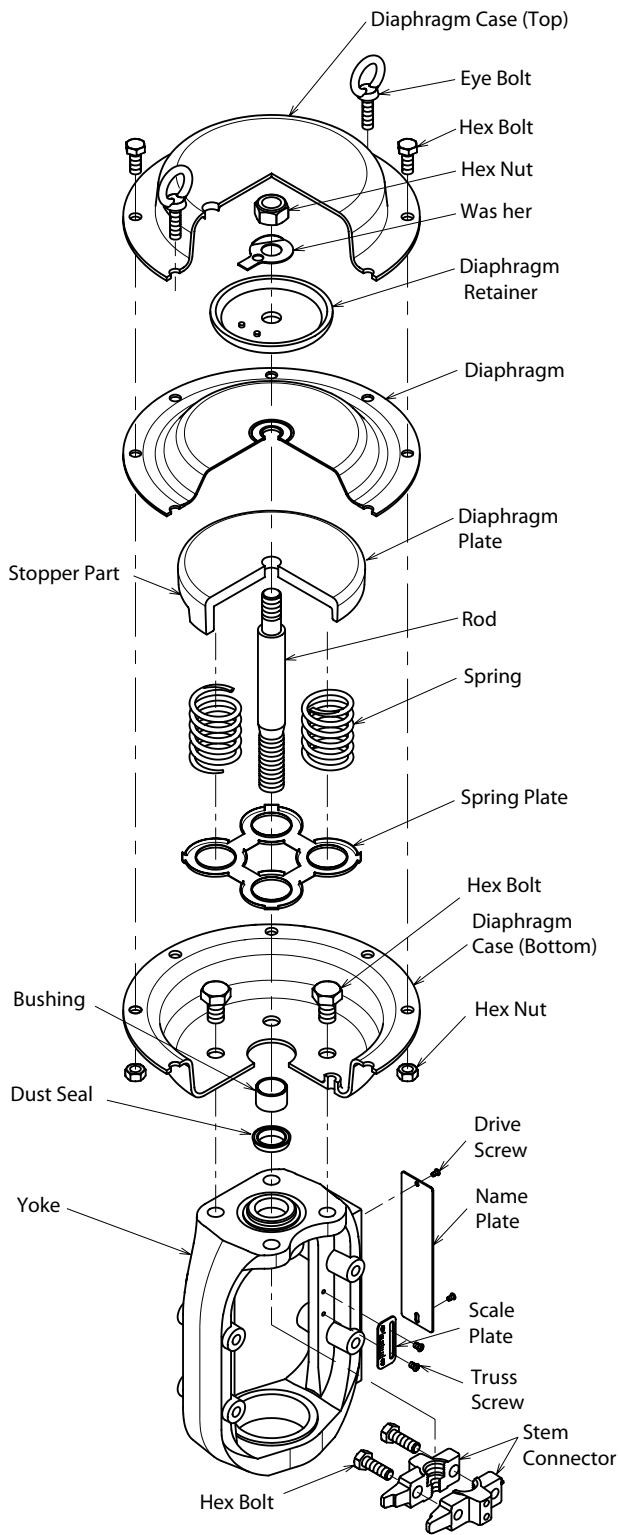

Figure 4-4 Direct Action model PSA1D

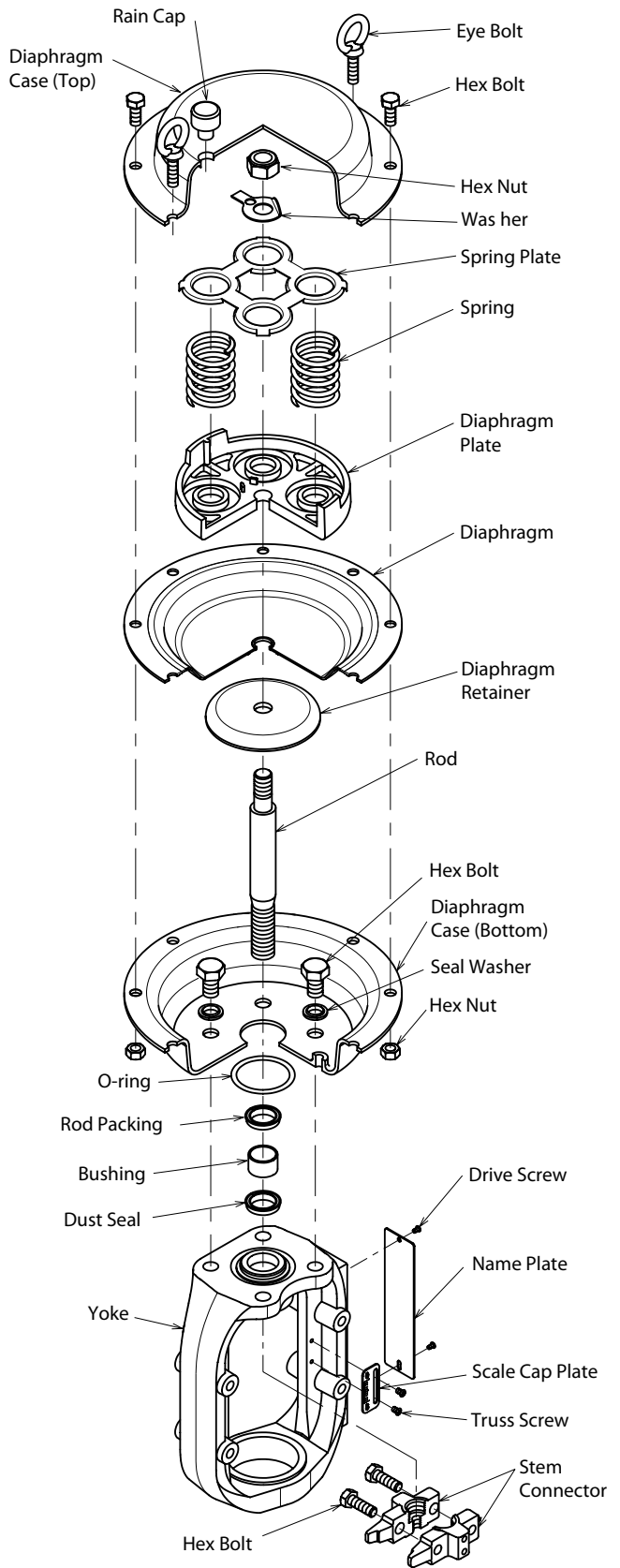

Figure 4-5 Reverse Action model PSA1R

## Assembly

Before assembly, check the parts for scratches, damage, deformation, peeling paint or any other abnormalities. To assemble the actuator, proceed as follows:

### A. Direct action models

- (1) Secure the diaphragm case (bottom) with the four bolts to the yoke. At the same time, set the air vent hole as in Figure 4-6. For model PSA1D actuator, secure the spring plate to the diaphragm case and yoke.
- (2) Fasten the spring plate and install the springs onto the spring plate (see Figure 4-6).
- (3) Insert the actuator rod (with diaphragm connected) into the bushing. Be careful to prevent the bushing's inside surface or dust seal from being damaged by the threaded section of the rod. If possible, cover the threaded section with adhesive tape.
- (4) Rotate the actuator rod, locating the diaphragm plate stopper as shown in Figure 4-6.
- (5) Place the top diaphragm case and secure it with the pair of eyebolts.

Note: Set the air pipe connection port to the location shown in Figure 4-6. Tighten the pair of eyebolts uniformly and alternately. The initial setting of the springs is completed by tightening these eyebolts.

- (6) Clamp the diaphragm case with clamping bolts.
- (7) Install the stem connector. Connect the air pipe to its connection port at the top diaphragm case.
- (8) After completing assembly, check the following:
  - Apply air pressure of 490 kPa {5 kgf/cm<sup>2</sup>} through the air pipe connection port at the top diaphragm case, and check the diaphragm periphery for air leakage with soapy water.
  - Check that the actuator operates smoothly through to its full stroke by operating it as an independent unit.

 <b>CAUTION</b>
Install packing for the rod and dustseal in the correct direction. Refer to Figure 4-4.

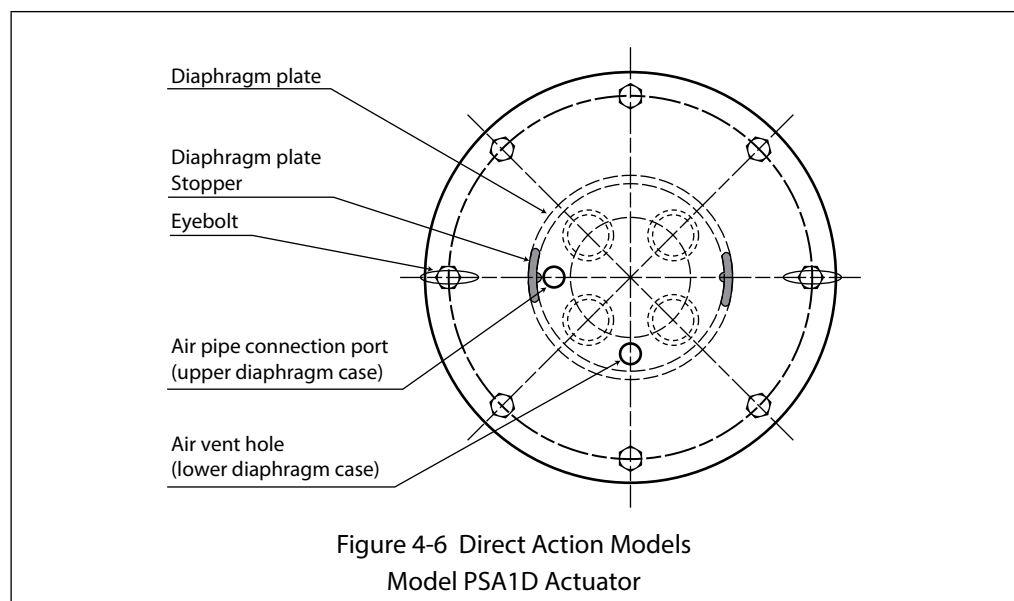



## B. Revers action models

- (1) Secure the bottom diaphragm case with the four bolts to the yoke. At the same time, set the air pipe connection port in the location shown in the Figure 4-7.
- (2) Insert the actuator rod (with diaphragm connected) into the bushing. Be careful to prevent the bushing 's inside surface or dust seal from being damaged by the threaded section of the rod. If possible, cover the threaded section with adhesive tape.
- (3) Rotate the actuator rod, locating its diaphragm plate stopper as shown in Figure 4-7.
- (4) Fasten the spring plate and install the springs onto the spring plate. (see Figure 4-7).
- (5) Place the top diaphragm case and secure it with the pair of eyebolts.

Note: Set the air vent hole to the location shown in Figure 4-7. Uniformly and alternately tighten the eyebolts. The initial setting of the springs is completed by tightening these eyebolts.

- (6) Clamp the diaphragm case with clamping bolts.
- (7) Install the stem connector.
- (8) Install the stem cap onto the air vent port.
- (9) Connect the air pipe to its connection port at the bottom diaphragm case.
- (10) After completing of assembly, check the following.
  - Apply air pressure of 500 kPa {5 kgf/cm<sup>2</sup>} through the air pie connection port at the diaphragm case, and check the diaphragm periphery for air leakage with soapy water.
  - Check that the actuator operates smoothly through to its full stroke by operating the actuator as an independent unit.

### CAUTION

Install packing for the rod and dustseal in the correct direction.  
Refer to Figure 4-5.

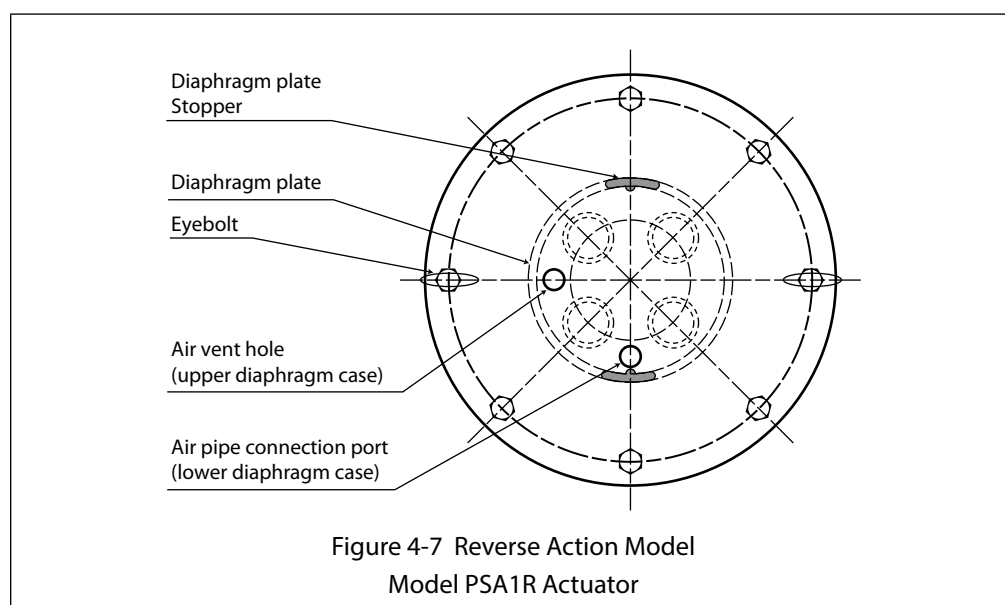

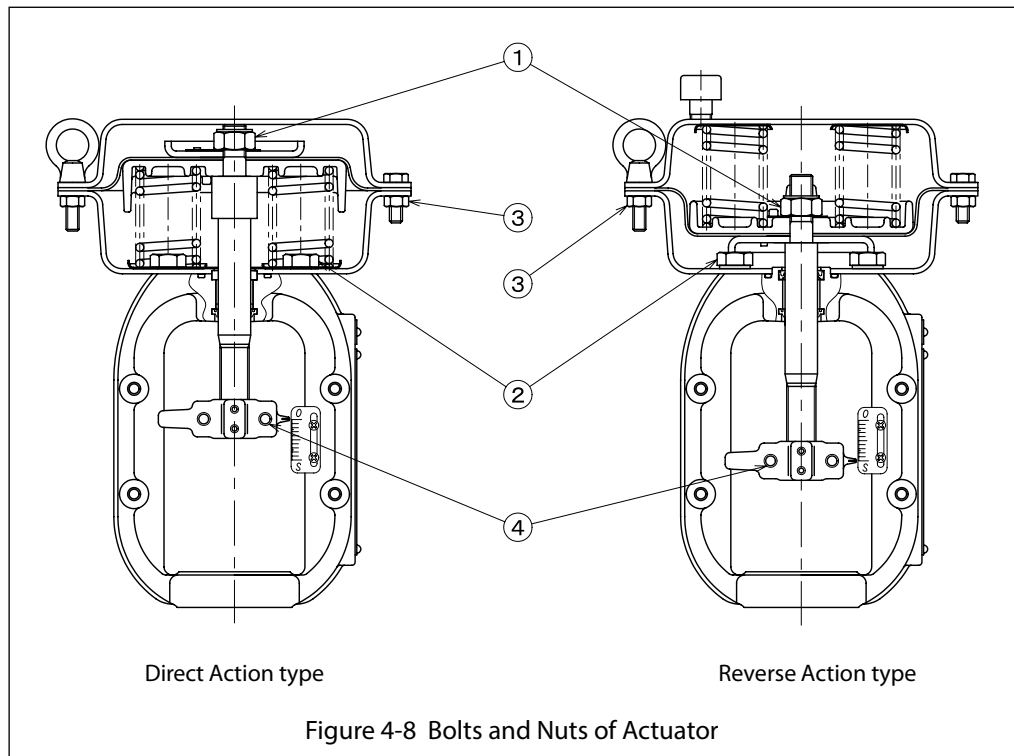

Figure 4-8 Bolts and Nuts of Actuator

Table 4-4 Tightening Torques of Bolts and Nuts of Actuator

Unit:(N·m{kgf·cm})

No.	Materials	Model PSA1D	
1	SK5 S45C	M14	45-70
			{460-710}
2	S30C	M12	35-50
			{360-510}
3	SUS304	M8	15-20
			{150-200}
4	SUS304	M8	10-15
			{100-150}

Note: Install the rain cap on the reverse actuator as follows. Drive the cap into the diaphragm case until the shoulder (brim) of the cap is brought into contact with the diaphragm case, then drive the cap further into the diaphragm case by half a turn.

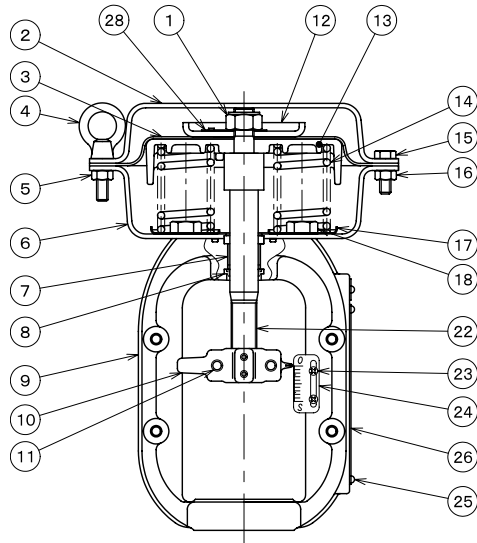

Direct Action type

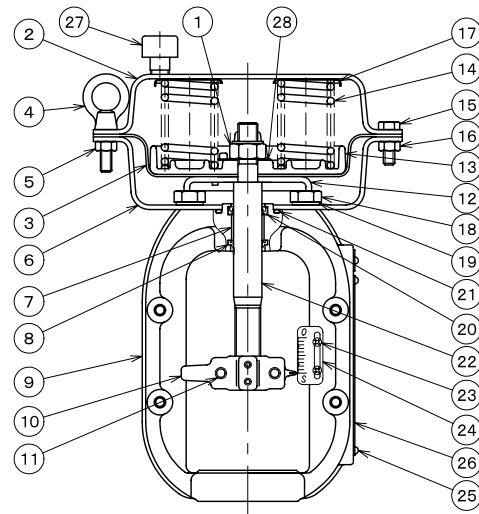

Reverse Action type

Figure 4-9 Model PSA Actuator

No.	Parts Name	Material
1	Nut	S45C, SUS301
2	Diaphragm Case (Top)	SAPH400
3	Diaphragm	EPDM, Polyimide
4	Eye Bolt	SUS304
5	Hex Nut	SUS304
6	Diaphragm Case (Bottom)	SAPH370
7	Bushing	SPCC, Bronze, PTFE
8	Dust Seal	NBR
9	Yoke	A216WBC
10	Stem Connector	SCS13A
11	Hex Bolt	SUS304
12	Diaphragm Retainer	SS400
13	Diaphragm Plate	AC4A-F
14	Spring	SWOSM-B

No.	Parts Name	Material
15	Hex Bolt	SUS304
16	Hex Nut	SUS304
17	Spring Plate	SUS304CP
18	Hex Bolt	S30C
19	Seal Washer	NBR, SPCC
20	Rod Packing	NBR
21	O-Ring	NBR
22	Rod	SUS304
23	Truss Screw	SUS304, SK5
24	Scale Plate	SUS304CP
25	Drive Screw	SUS304
26	Name Plate	SUS304CP
27	Rain Cap	SUS304
28	Washer	SUS304CP

## 4-5. Disassembly and assembly of model HA2, HA3, or HA4 actuator

### Disassembly Procedure

#### (a) Direct Action Type

- (1) Disconnect the air piping and detach the accessories from the actuator.
- (2) Remove the stem connector, pointer and lock nut. (See Figure 4-17)
- (3) Remove the clamping-bolts (except the pair of eyebolts) of the diaphragm case.
- (4) Loosen evenly and alternately the pair of eyebolts. (The initial setting of the springs is done by these eyebolts.)
- (5) Remove the diaphragm case. Pull out upward the actuator rod together with the diaphragm.
- (6) Take out the springs.

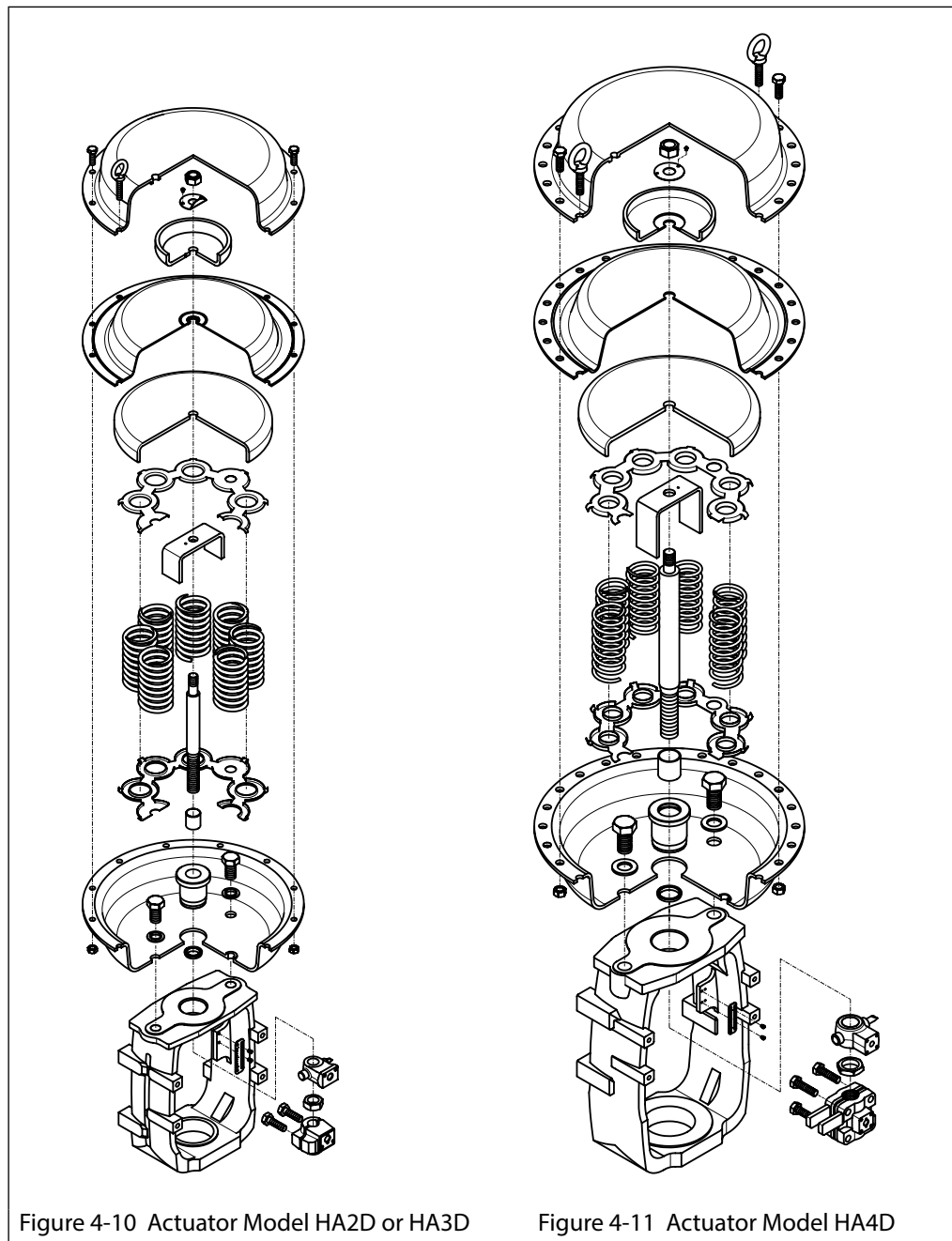

Figure 4-10 Actuator Model HA2D or HA3D

Figure 4-11 Actuator Model HA4D

**(b) Reverse Action Type**

- (1) Disconnect the air piping and detach other external items from the actuator.
- (2) Remove the stem connector, pointer and lock nut. (See Figure 4-17)
- (3) Remove the clamping-bolts (except the pair of eyebolts) of the diaphragm case.
- (4) Loosen evenly and alternately the pair of eyebolts. (The initial setting of the springs is done by these eyebolts.)
- (5) Remove the diaphragm case. Take out the springs.
- (6) Pull out upward the actuator rod together with the diaphragm.

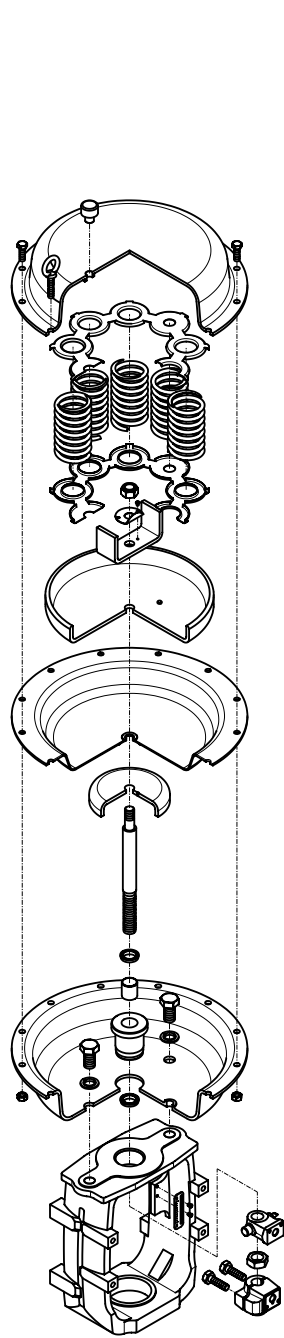

Figure 4-12 Actuator Model HA2R or HA3R

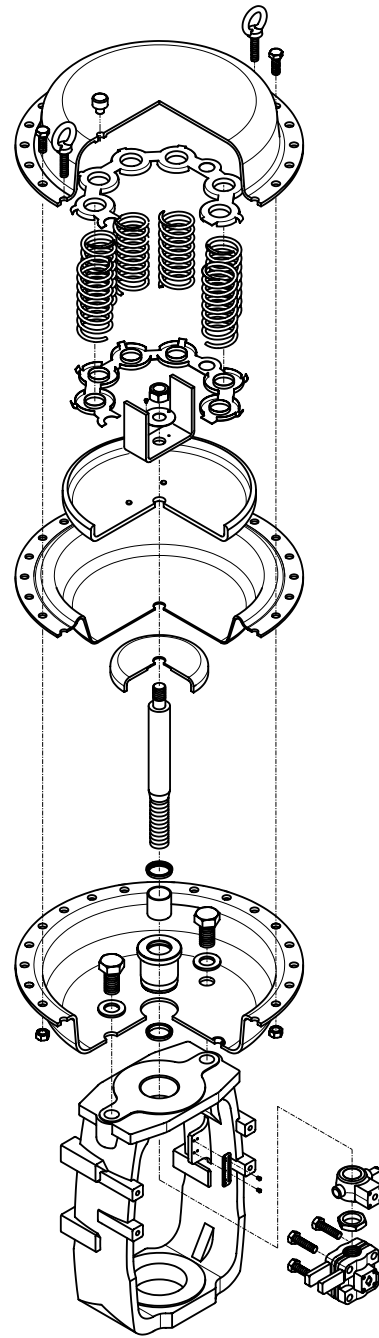

Figure 4-13 Actuator Model HA4R

## Assembly Procedure

Before assembly, check the parts for scrapes, damage, deformation, peeling off of paint, and other abnormality. To assemble the actuator, proceed as follows:

### (a) Direct Action Type

- (1) Fix the bottom diaphragm case and yoke with the bolts. (For models HA2D and HA3D, install the diaphragm case and spring plate together.)
- (2) Install the springs on the spring plate. The quantities of springs are as follows:  
Model HA2.....4 springs  
Model HA3, HA4.....8 springs  
Except particular models as follows:  
Model HA2, 38 mm stroke,  
80 - 240 kPa (0.8 - 2.4 kgf/cm<sup>2</sup>)..... Total 8 springs (with double springs)  
Model HA3, 50 mm stroke,  
80 - 240 kPa (0.8 - 2.4 kgf/cm<sup>2</sup>)..... Total 16 springs (with double springs)  
Model HA4, 75 mm stroke,  
80 - 240 kPa (0.8 - 2.4 kgf/cm<sup>2</sup>)..... Total 16 springs (with double springs)
- (3) Insert the actuator rod (to which the diaphragm is connected) into the bushing, exercising care not to damage the bushing inside surface or dust seal with the threaded section of the rod. (For example, cover the threaded section with adhesive tape to prevent damaging the bushing.) Set the stopper in parallel with the yoke.
- (4) Place the top diaphragm case and fix it with the pair of eyebolts.

Note: • Set the air piping connection port in the location shown in the illustration. (Figure 4-14)

- Tighten the pair of eyebolts uniformly by tightening them alternately. The initial setting of the springs is complete by tightening of these eyebolts.

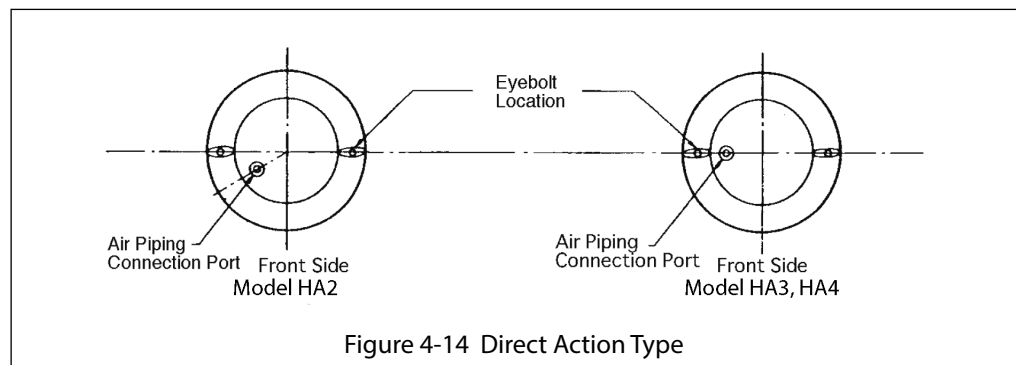

- (5) Clamp the diaphragm case with other clamping-bolts than the pair of eyebolts.
- (6) Install the pointer, secure the lock nut, and install the stem connector. (Connect the air pipe to the air piping connection port of the top diaphragm case.)
- (7) After the assembly is complete as above, check the following.
  1. Applying an air pressure of 500 kPa (5 kgf/cm<sup>2</sup>) via the air piping connection port of the top diaphragm case, check the diaphragm periphery for air leak by using soapsuds.
  2. Check that the actuator smoothly operates for its full stroke.

Note: Check this operation by operating the actuator as an independent unit.

**(b) Reverse Action Type**

- (1) Fix the bottom diaphragm case and yoke with the bolts.
- (2) Insert the actuator rod (to which the diaphragm is connected) into the hushing, exercising care not to damage the bushing inside surface or dust seal with the thread section of the rod. (For example, cover the threaded section with adhesive tape to prevent damaging the bushing.)
- (3) Make the stopper (in the diaphragm plate) in parallel with the yoke by turning the rod.
- (4) Install the springs on the spring plate. The quantities of springs are as follows:  
Model HA2.....4 springs  
Model HA3, HA4.....8 springs  
Except particular models as follows:  
Model HA2, 38 mm stroke,  
80 - 240 kPa (0.8 - 2.4 kgf/cm<sup>2</sup>)..... Total 8 springs (with double springs)  
Model HA3, 50 mm stroke,  
80 - 240 kPa (0.8 - 2.4 kgf/cm<sup>2</sup>)..... Total 16 springs (with double springs)  
Model HA4, 75 mm stroke,  
80 - 240 kPa (0.8 - 2.4 kgf/cm<sup>2</sup>)..... Total 16 springs (with double springs)
- (5) Place the top diaphragm case and fix it with the pair of eyebolts. Set the air vent hole in the location shown in the illustration (Figure 4-15). Uniformly and alternately tighten the eyebolts. The initial setting of the springs is complete by tightening of these eyebolts.

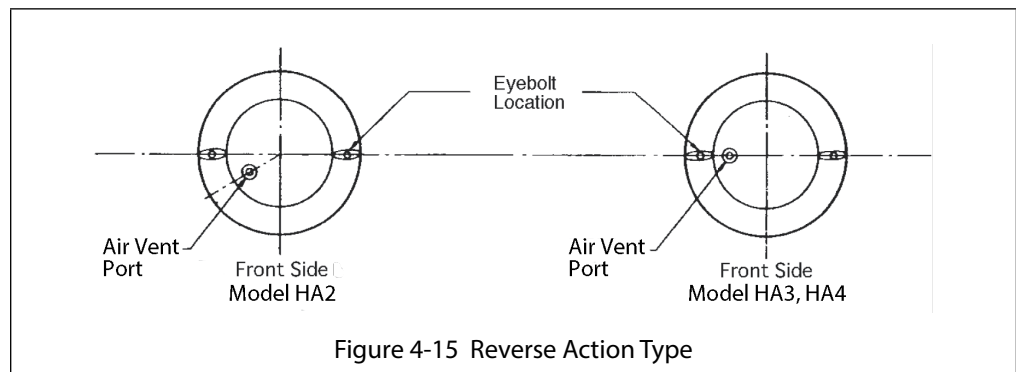

Figure 4-15 Reverse Action Type

- (6) Clamp the diaphragm case with other clamping-bolts than the pair of eyebolts.
- (7) Install the pointer, secure the lock nut, and install the stem connector.
- (8) Install the rain cap on the air vent port.
- (9) Connect the air pipe to the air piping connection port of the bottom diaphragm case.
- (10) After the assembly is complete as above, check the following.
  1. Applying an air pressure of 500 kPa (5 kgf/cm<sup>2</sup>) via the air Piping connection port of the bottom diaphragm case, check the diaphragm periphery for air leak by using soapsuds.
  2. Check that the actuator smoothly operates for its full stroke.Note: Check this operation by operating the actuator as an independent unit.

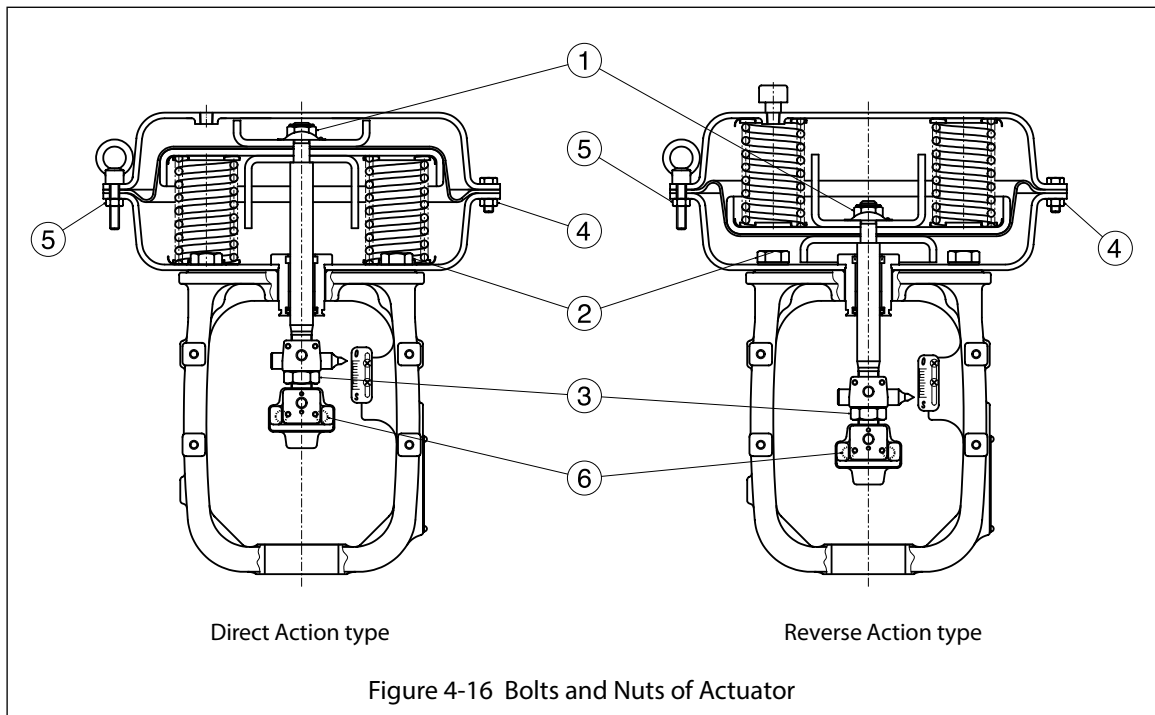
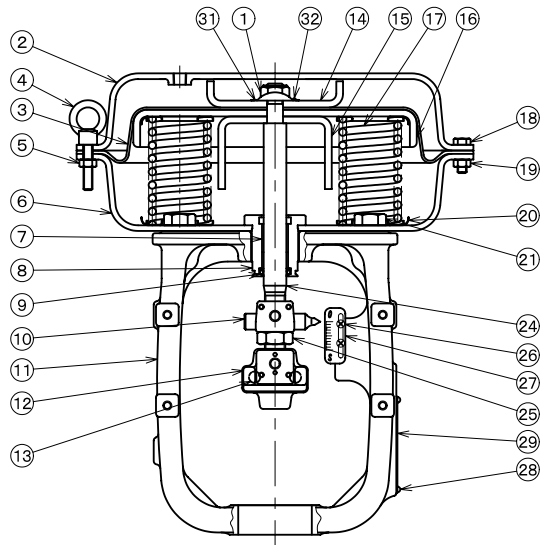

Table 4-5 Tightening Torques of Bolts and Nuts of Actuator

Unit:(N·m{kgf·cm})

No.	Materials	For Model HA2		For Model HA3		For Model HA4	
		Material	Torque	Material	Torque	Material	Torque
1	S45C/SUS301	M10	37 {370}	M14	100 {1,000}	M20	310 {3,170}
2	S30C	M12	42 {420}	M16	100 {1,000}	M24	360 {3,360}
3	SUS304	M14	69 {690}	M18	140 {1,400}	M30	710 {7,160}
4	S20C	M8	16 {160}	M8	16 {160}	M12	55 {550}
5	SUS304	M8	18 {180}	M8	18 {180}	M12	63 {630}
6	SUS304	M10	56 {560}	M10	56 {560}	M12	63 {630}





Direct Action Type (Model HA3D)

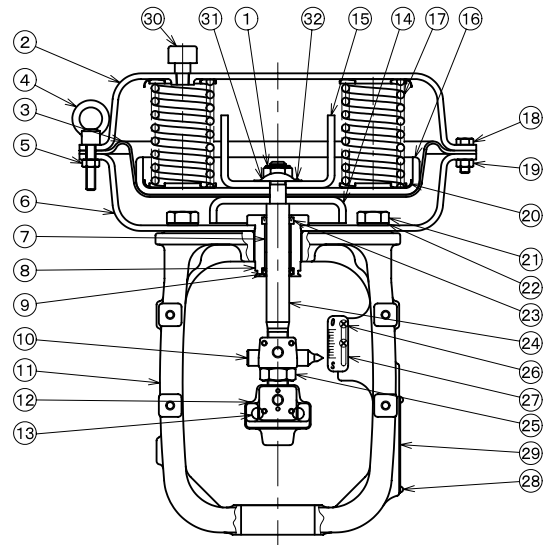

Reverse Action Type (Model HA3R)

No.	Parts Name	Material
1	Nut	S45C, SUS301
2	Diaphragm Case (Top)	SAPH370
3	Diaphragm	EPDM+Nylon66
4	Eye Bolt	SUS304
5	Hex Nut	SUS304
6	Diaphragm Case (Bottom)	SAPH370
7	Bushing	SPCC, Bronze, PTFE
8	Bearing	S25C
9	Dust Seal	NBR
10	Pointer	S25C
11	Yoke	SCPH2, A216WBC
12	Stem Connector	S25C, S20C
13	Hex Bolt	SUS304, S30C
14	Diaphragm Retainer	SS400
15	Stopper	SS400
16	Diaphragm Plate	SS400

No.	Parts Name	Material
17	Spring	SWOSM-B
18	Hex Bolt	SUS304
19	Hex Nut	SUS304
20	Spring Plate	SPCC
21	Hex Bolt	S30C
22	Seal Washer	NBR, SPCC
23	Rod Packing	NBR
24	Rod	SUS304
25	Lock Nut	SUS304
26	Truss Screw, Spring Washer Nut, or Speed Nut	SUS304, SK5
27	Scale Plate	SUS304CP
28	Screw	SUS304
29	Name Plate	SUS304CP
30	Rain Cap	SUS304
31	Washer	SPCC
32	Tapping Screw	S20C

Figure 4-17 Cut View of Actuator

## 4-6. Disassembly and assembly of model PSA6 actuator

### Structure

This actuator is comprised of a cylinder, spring unit, lift stopper, spring retainer, hex stay, yoke, manual handwheel and a single action positioner.

For an external view of the a actuator, refer to Figure 4-18 "Exterior of Model PSA6R".

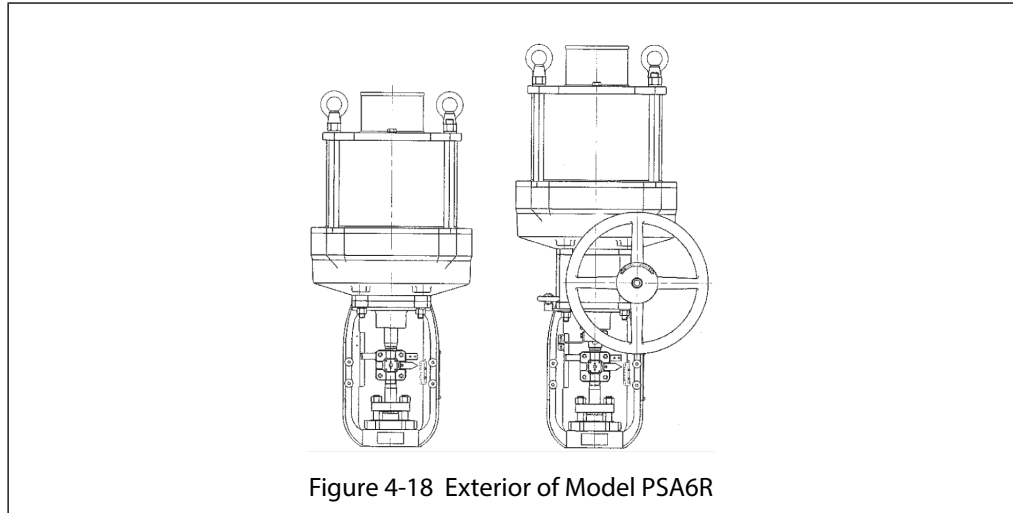

Figure 4-18 Exterior of Model PSA6R

### Assembly on valve body

The Assembling nuts are integral to the valve body connect the yoke and valve body. The stem connector connects the actuator's rod and valve stem.

### Air piping connection

The tubing is connected to the single action positioner when used as a control valve. Refer to the following instruction manuals for details on the single action positioners.

- Pneumatic positioner (Model HTP) No. OM2-8310-0200
- Electro-pneumatic positioner (Model HEP) No. OM2-8310-0100
- Electro-pneumatic positioner (Model AVP 300/301/302/200/201/202)  
No. CM2-AVP300-2001
- Electro-pneumatic positioner (Model AVP 303/203)  
No. CM2-AVP303-2001
- Smart valve positioner 700 series with HART type (Model AVP701/702)  
No. CM2-AVP702-2001
- Smart valve positioner 700 series with FOUNDATION Fieldbus type (Model AVP703)  
No. CM2-AVP703-2001

### Calibration

This actuator does not require any calibration.

When connecting the valve stem of the valve body with the actuator's rod using a stem connector, adjustment should be made to sit the valve plug onto the seat ring. Then screws on actuator's scale plate are loosened, and the stroke and index matched to properly position the scale plate.

## ⚠ CAUTION

In operation and handling

- When automatically operating an actuator with the manual handwheel, verify that the AUTO/MANUAL switchover pin is inserted into the pin holder, the chain is engaged with the handwheel and the indicator is in AUTO position starting operation.
- When disassembling and assembling, always hold the actuator in an upright position (spring unit on top and yoke on the bottom)
- While eyebolts are used to suspend the actuator, an assembled valve should not be suspended with the eyebolts only.

### AUTO/MANUAL switchover of manual handwheel

With an actuator with the AUTO/MANUAL switchover function, switchover between automatic operation and manual operation using the handwheel is possible. See Figure 4-19. AUTO/MANUAL switchover can be made at any time during operation.

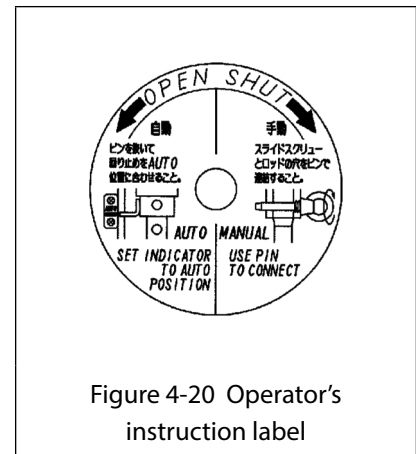
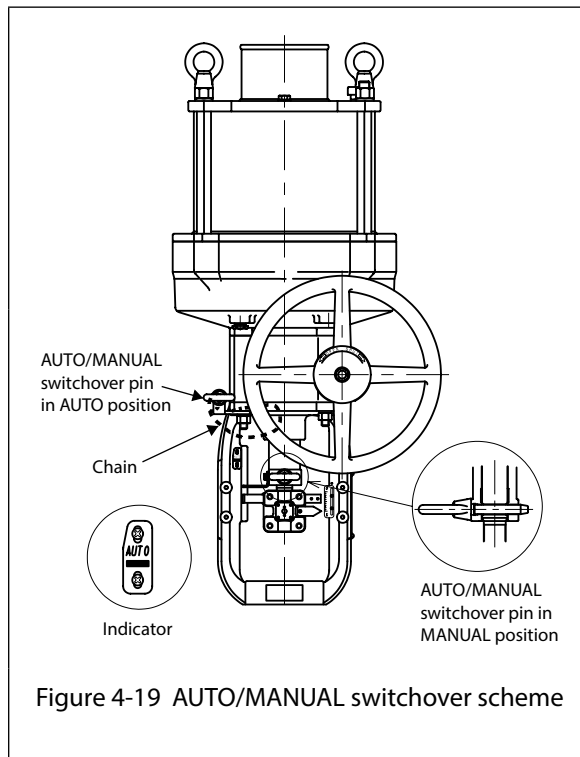

**Procedure**

Step	Procedure
1	Pull AUTO/MANUAL switchover pin out of its holder and disengage the chain, that connects the handwheel with the wheel.
2	Check the label on the handwheel and turn the handle in the shut direction and lower the slide screw.
3	Align the round holes of the slide screw and the actuator rod, and then insert pin. Push it all the way in and fix it there.
4	Verify OPEN and SHUT arrows on the label, and turn the handwheel either direction to open or close the valve. The turning torque should be under 127N (13 kgf).
5	<p>When the handwheel does not turn any further, check valve opening and then finish.</p> <div data-bbox="563 842 1415 1014" style="border: 1px solid black; padding: 5px;"> <p style="text-align: center;"><b>⚠ CAUTION</b></p> <p>Do not apply undue force onto the valve when it comes to full stop. Otherwise the valve stem may be damaged. Refer to "Chapter 12. Troubleshooting" for remedial action.</p> </div>
6	<p>To resume automatic operation, remove the switchover pin, turn handwheel until the slide screw stop reaches AUTO position (see Figure 4-21 below). Run the chain on the pin through in order to restrict handwheel movement and fix the pin on the holder. Resume automatic operation after verifying this condition.</p> <div data-bbox="847 1245 1126 1525" style="text-align: center;"> </div> <p style="text-align: center;">Figure 4-21</p>

## 4-7. Disassembly and assembly actuator

Disassembly and assembly procedures are described herein. Refer to them for periodic maintenance or if a malfunction occurs which may call for the disassembly or assembly of the actuator.

### Before disassembly

- (1) Only the nuts for the eyebolts are made of stainless steel. Keep these nuts separate from other nuts when disassembling the diaphragm case.
- (2) Make locating marks on the top and bottom diaphragm cases before disassembling the valve. This will help you to find the air piping connector location easily.
- (3) Store the removed parts in a clean place.

### CAUTION

Use extreme care when removing the bolts and nuts from the actuator. The actuator contains powerful compressed springs that may cause physical injury or damage to equipment. When removing the bolts and nuts, be sure to closely follow the instructions given for the disassembly and assembly of the actuator and top hand wheel.

### Detaching actuator from valve body

Refer to “4-1. Detaching actuator from valve body” on page 4-1.

## Disassembly of actuator <Disassembly procedure>

Disassembly procedure of actuator is described herein. Refer to Figure 4-22 and Figure 4-23 or Table 4-6 for the information.

### 1. Marking and protection

Step	Procedure
1	Match the mark of the spring retainer No.10 at the top of actuator, lift stopper No.13, cylinder No.14 and cylinder assembling yoke boss.
2	Wrap PVC tape around thread part of rod to protect sealing parts, and the guide bushing.

### 2. Removing slide screw rotation stopper (In case of with handwheel)

Step	Procedure
1	Loosen hex head bolt No.37 and hex nuts Mo.38 which fasten the slide screw rotation stopper No.36.
2	Remove slide screw rotation stopper No.36.

### 3. Removing spring retainer

Step	Procedure
1	Loosen hex nuts No.2 and eye nut No.1 at the top of actuator and remove.
2	Lift spring retainer No.10 straight up and remove.

### 4. Removing lift stopper and spring unit

Step	Procedure
1	Loosen hex stays No.4 (four stays) which fasten lift stopper No.13 and cylinder No.14 and remove.
2	Raise lift stopper 13 straight up and remove.
3	Install eyebolts in the threaded holes on the spring receiver No.9 which is located on the top of spring unit (M12*2) and lift spring unit (approximately 120 kg) up with a crane.
4	While suspended by crane, remove the piston's No.3 sealing parts (tape liner No.14, O-ring No.15)

### 5. Removing slide screw and cylinder

Step	Procedure
1	Turn slide screw No.32 by hand and extract from the bottom.
2	Loosen hex head bolts No.6 (four bolts) which fasten the cylinder and manual handwheel and remove.
3	Lift cylinder straight up and remove.

### 6. Removing worm unit (In case of with handwheel)

Step	Procedure
1	Remove in sequential order the bearing holder No.29, single column angular bearing, (upper) No.30, worm wheel No.31, and single column angular bearing (lower) No.30.
2	Loosen hex head bolts No.9 (four), which fasten the gear case No.28 and yoke and remove.

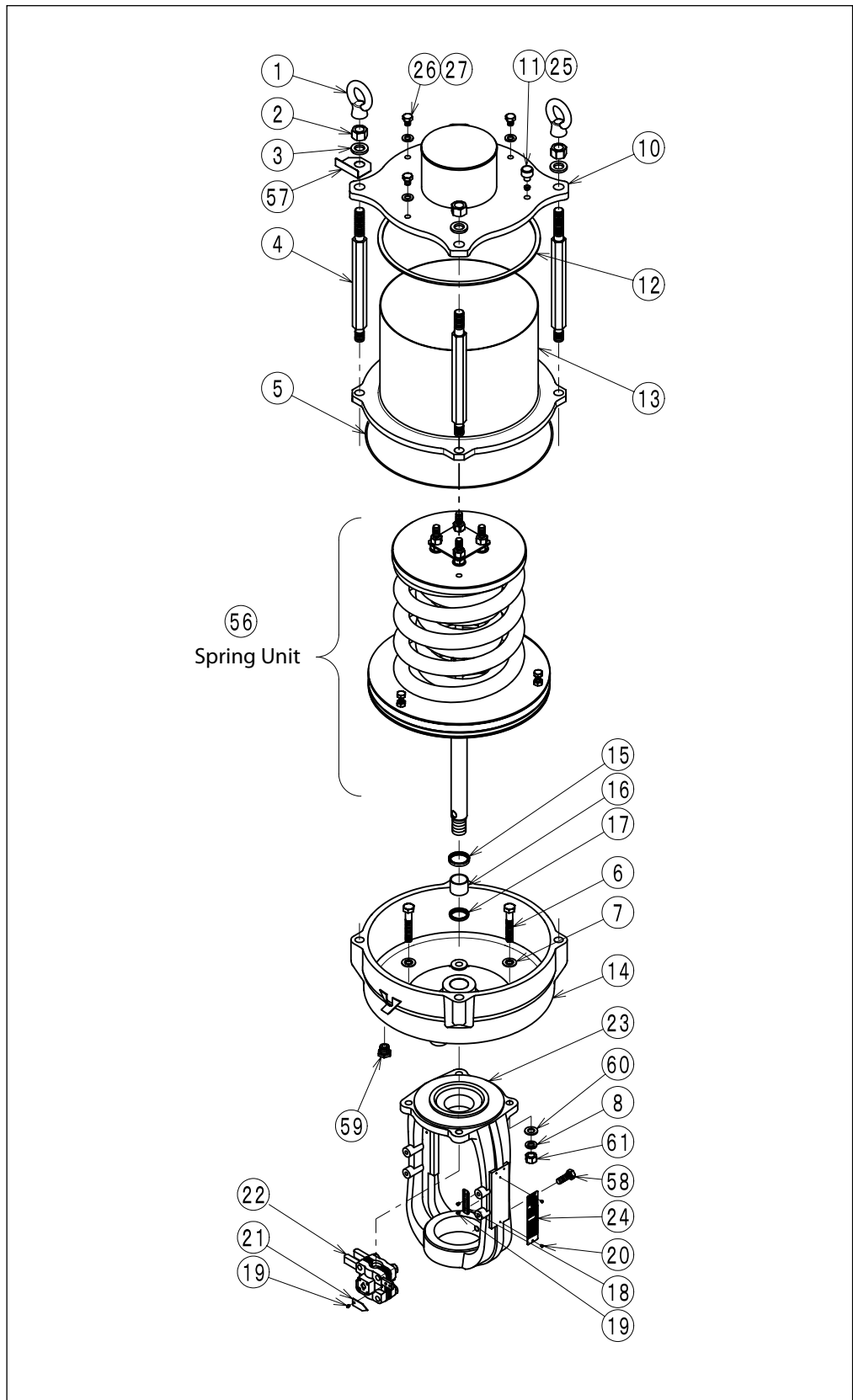

Figure 4-22 Model PSA6R



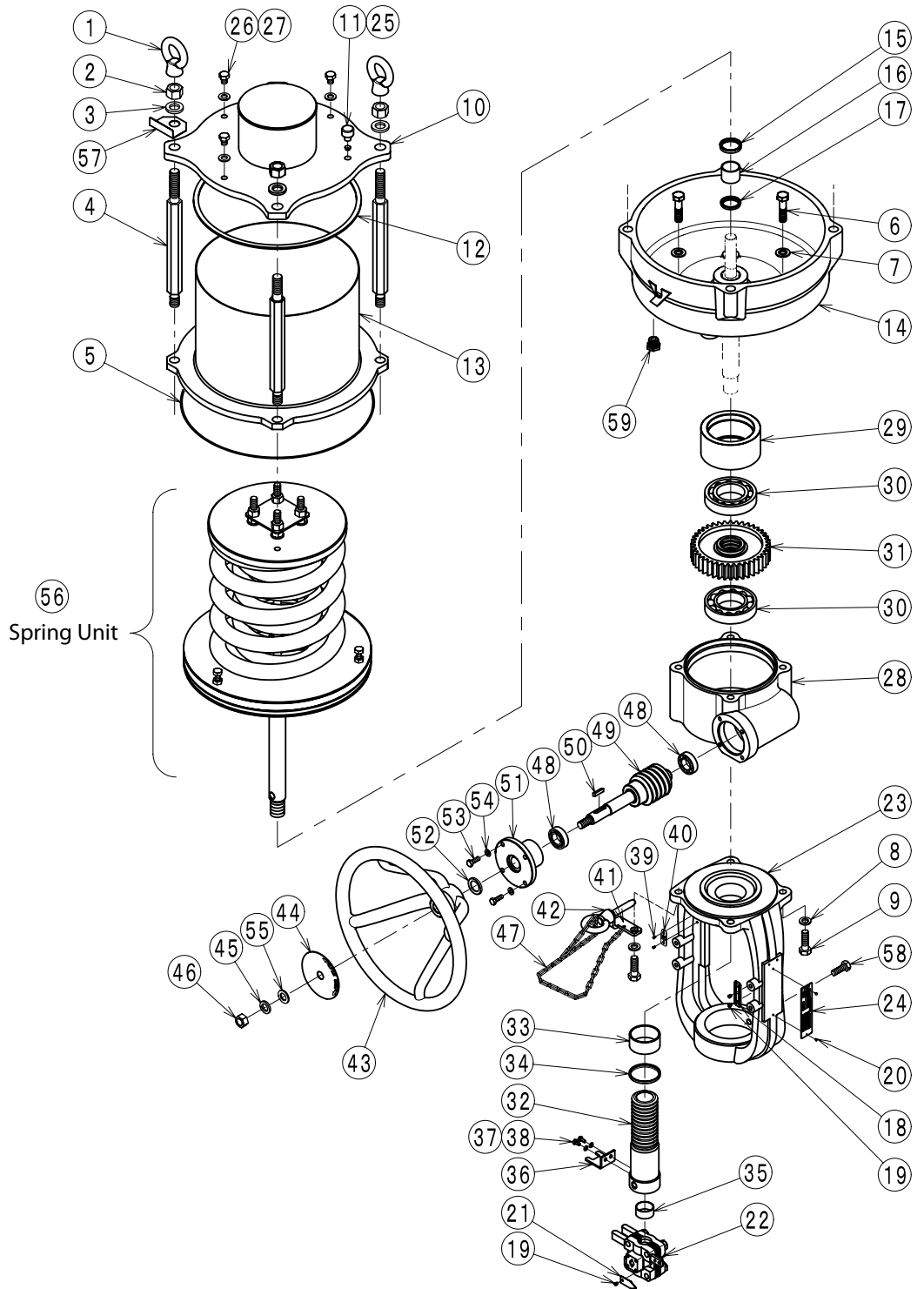

Figure 4-23 Model PSA6R with Handwheel

Table 4-6 Parts reference list

No.	Parts description
1	Eye Nut
2	Hex Nut
3	Spring Washer
4	Hex Stay(Long)
5	O-Ring
6	Hex Bolt
7	Seal Washer
8	Spring Washer
9	Hex Bolt
10	Spring Retainer
11	Rain Cap
12	Lift Stopper Seal
13	Lift Stopper
14	Cylinder
15	Rod Packing
16	Bushing
17	Dust Seal
18	Scale Plate
19	Truss Screw
20	Drive Screw
21	Pointer
22	Stem Connector
23	Yoke
24	Name Plate
25	Filter Screen
26	Hex Bolt
27	Washer
28	Gear Case
29	Bearing Holder
30	Single Column Angular Bearing
31	Worm Wheel

No.	Parts description
32	Slide Screw
33	Bushing
34	Dust Seal
35	Tape Liner
36	Slide Screw Rotation Stopper
37	Hex Bolt
38	Seal Washer
39	Truss Screw
40	Indicator
41	Pin Holder
42	Pin
43	Handwheel
44	Operating Instruction Label
45	Spring Washer
46	Hex Nut
47	Chain
48	Single Column Angular Bearing
49	Worm Shaft
50	Key
51	Gear Case Cap
52	Dust Seal
53	Hex Bolt
54	Hex Nut
55	Washer
56	Spring Unit
57	Caution Plate
58	Hex Bolt
59	Bushing Joint
60	Washer
61	Hex Nut

No.	Parts description
1	Rod
2	O-Ring
3	Piston
4	Spring Washer
5	Locking Nut
6	Stopper
7	Spring (Small)
8	Spring (Large)
9	Spring Receiver
10	Hex Nut
11	Stopper Retainer
12	Hex Bolt
13	Hex Nut
14	Wear Ring
15	O-Ring
16	Washer

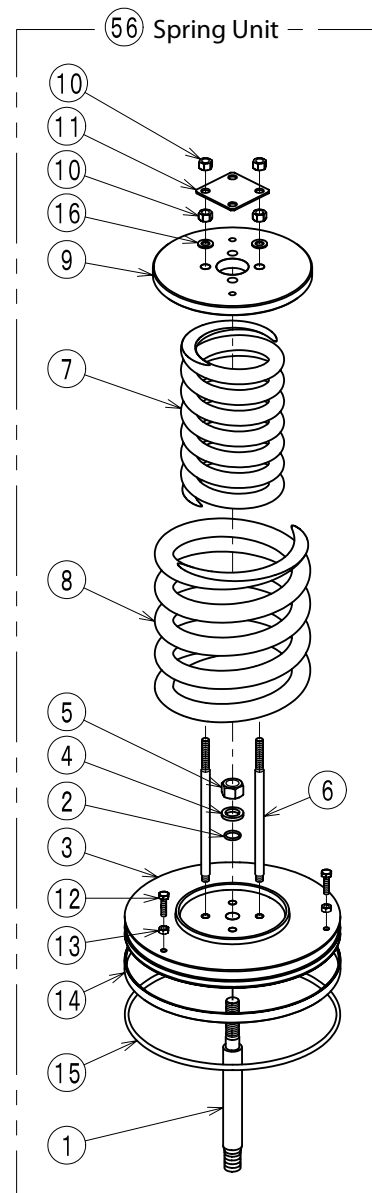

Figure 4-24 Spring Unit

## Disassembling spring unit

### <disassembly procedure>

The disassembly procedure of spring unit is described herein.

See Figure 4-24 for reference on part names.

Disassembly is not required if only the piston's sealing parts (tape liner, O-ring) are to be replaced.

### 1. Removing spring unit

Step	Procedure
1	Loosen hex nuts No.10 (four at the top) and remove.
2	Remove stopper retainer No.11.
3	Evenly loosen hex nuts No.10 (four at the bottom) until there is no tension on springs No.7 and No.8. <div style="border: 1px solid black; padding: 5px; margin-top: 10px;"><p style="text-align: center;"> <b>CAUTION</b></p><p>Follow the disassembly procedure of spring unit when removing bolts and nuts. Otherwise, the release of the springs may result in physical injury.</p></div>
4	Remove spring receiver No.9.
5	Remove springs (large No.8, small No.7).

### 2. Removing piston unit

Step	Procedure
1	Loosen stopper No.6 and remove.
2	Loosen locking nut No.5 and remove, using the flat faces of rod No.1.
3	Remove spring washer No.4, O-ring No.2. Exercise care so as not to damage the O-ring with the rod screw.
4	Separate rod No.1 from piston No.3.

## Assembling actuator

### <Cautions during assembly>

- Refer to the chapter of inspection items during disassembly and verify that no abnormality is found on the parts. If any are found, replace or repair as required.
- The O-ring of sliding parts should always be replaced at the time of periodic disassembly. Whenever the O-ring on the fixed part is deformed, damaged, or scarred during disassembly, replace it.
- Clean the O-ring, oil seal, wearing, and tape liner O-ring recess and apply sufficient of lubricant.
- Ensure that no dust or dirt from maintenance work prior to reassembly remains on sliding part of cylinder and guide bushing.

## Assembly of actuator with manual handwheel

See Figure 4-23 and Figure 4-24 for assembly on part names.

### 1. Assembly of manual handwheel and cylinder assembly

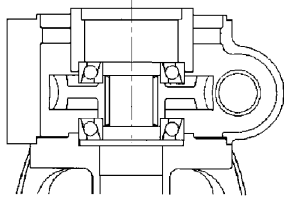
Step	Procedure
1	While yoke No.23 is in upright position, place gear case No.28 and temporarily fasten it with hex head bolts No.9 (four).
2	Apply lubricant on the single column angular bearing (top and bottom) and assemble in sequential order the bearing (lower) No.30, worm wheel No.31, Bearing (upper) No.30 and bearing holder No.29. See Figure 4-25 below.  <div style="text-align: center;">  <p>Figure 4-25</p> </div>
3	Insert and screw in from the bottom slide screw No.32 assembled with tape liner No.14. Apply Inbricant on the threaded parts of slide screw No.32.
4	Assemble slide screw No.32 with slide screw rotation stopper No.36, hex head bolt No.37 and nut No.38.
5	Apply lubricant on rod packing No.15 and dust seal No.17 and assemble them into cylinder No.14.
6	Place cylinder No.14 on gear case No.28 and temporarily fasten it with hex head bolts No.6 (four) and seal washer No.7.
7	Use rod No.1 to set the position of the cylinder by ensuring that the rod moves smoothly and the tighten with the torque given on Table 4-5. If the rod does not move smootyly, tap the cylinder or gear case gently with plastic hammer and set the position.

## 2. Assembly of piston unit, lift stopper and spring retainer

Step	Procedure
1	Install eyebolts into threaded holes (M12*2) at the top of spring retainer No.9 on the piston unit, suspend with crane and lift upward.
2	While suspended, assemble lubricated O-ring No.15 and wear ring No.14 on piston No.3.
3	Assemble piston unit in cylinder No.14 from the top. See to it that the round hole of rod 1 is on the front.
4	Assemble lift stopper seal No.12 in the slot on the top of cylinder no.14.
5	Insert lift stopper No.13 from the top and fix by hex stay No.4 (four). Screw in on the ones of the same length diagonally.
6	Assemble so that the hex stays No.4 fit into bolt holes of spring retainer No.10.
7	Fix spring retainer No.10 with hex head nuts No.2 (four).
8	Install eye nuts No.1 (two) on hex stay No.4.

### Assembly of actuator without manual handwheel

When assembling an actuator without a manual handwheel, follow the procedure given in "Assembly of actuator with manual handwheel" on page 36 except the applicable parts to actuator.

### Parts to be replaced

The actuator's parts have been designed to withstand prolonged usage. However, it is recommended that the following parts be replaced at these intervals:

Tape liner..... Every five years  
Bushing..... Every five years  
Seal washer..... Every five years  
Dust seal..... Every five years (to be replaced when disassembled)  
Rod packing..... Every five years (to be replaced when disassembled)  
O ring..... Every five years (to be replaced when disassembled)

## Tightening torques of actuator assembly

The table below lists the tightening torques for actuator assembly.  
Refer to Figure 4-26.

Table 4-7 Tightening torque of bolt and nuts of actuator

Key No.	Size	Tightening torque (N·m{kgf·cm})
1	M14	45-70 {450-700}
2	M20	160-215 {1600-2200}
3	M24	215-275 {2200-2800}
4	M14	45-70 {450-700}
5	M12	35-50 {350-500}

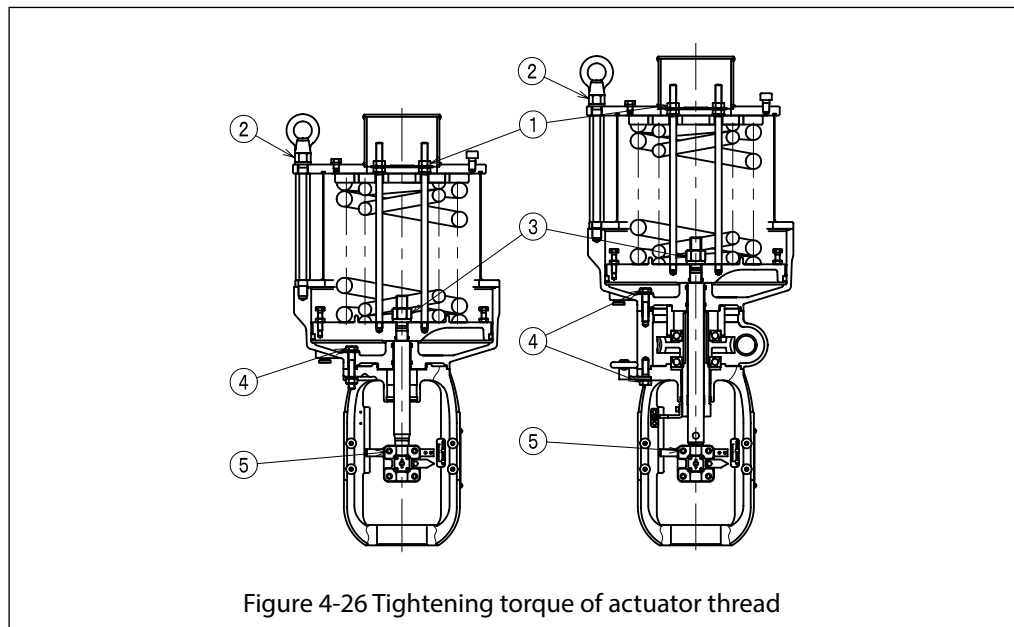

Figure 4-26 Tightening torque of actuator thread

## Chapter 5. Adjustment

As a general rule the diaphragm type control Valves require no adjustment. However, when coupling an actuator to a valve body after removing the actuator for overhaul or other purposes, adjustment of travel (stroke) is necessary. For this adjustment, refer to Figure 4-3, Figure 5-1 and proceed as follows:

- (1) Fix the actuator to the valve body by securely tightening the yoke clamping-nut (use a chisel and a hammer).
- (2) Connect an adjustable air pressure (with a pressure regulator) to the actuator - to the top diaphragm case for the direct action type or to the bottom diaphragm case for the reverse action type.
- (3) Lower the valve seat and check that it is contacted with the valve seat.

### **For the Direct Action Type**

- (4) Apply to the actuator the maximum air pressure corresponding to the spring range indicated on the nameplate.
- (5) Increase the air pressure to the supply pressure and check that the actuator stem moves by 1 - 2 mm in response. (This movement represents the allowance of stroke.)
- (6) Decrease the air pressure once. Then increase it again to the maximum value corresponding to the spring range, in the increasing direction.
- (7) In the above state, align the actuator stem and valve stem on a straight line, adjust so that the thread of the stem connector mates with those of actuator stem and valve stem and securely tighten the clamping-bolts of the stem connector. (See Figure 5-1.)

### **For the Reverse Action Type**

- (4) Apply to the actuator the minimum air pressure corresponding to the spring range indicated on the nameplate, and check that the actuator stem moves by 1-2mm in response.
- (5) Increase the air pressure once. Then decrease it again to the minimum value corresponding to the spring range, in the decreasing direction.
- (6) Perform a procedure identical with that of Item (7) of "For the Direct Action Type." (See Figure 5-1.)

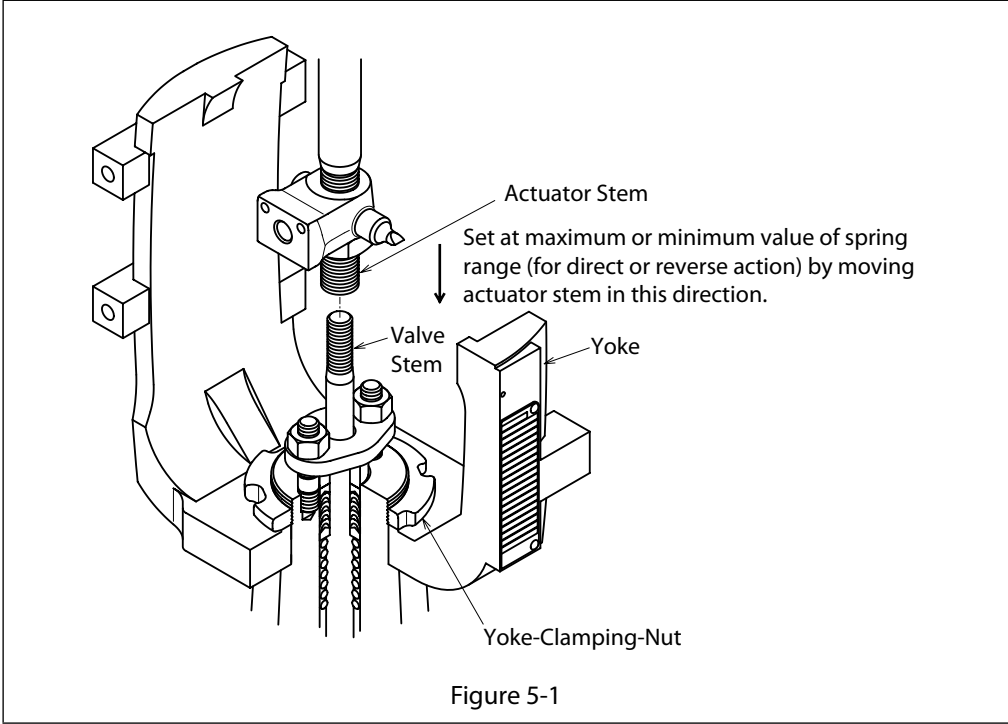



# Chapter 6. Direct/Reverse Action Type Conversion and Spring Range Change of Actuator

## 6-1. Direct/Reverse action change

As a general rule it is most recommendable to prepare separately the direct type and reverse type of actuators and not to convert actuators into different types. However, when it has become unavoidable to convert actuators into other types, conversions may be done by using the parts mentioned below (Table 6-1 and Table 6-2). The parts marked “+” are the ones which are newly needed and those marked “-” are ones which are not used.

Table 6-1. To Convert the Direct-Action Type into the Reverse Action Type

Model PSA1D -> Model PSA1R			
Parts name	Q'ty		
Rod unite	+1	82559228-102	14.3mm
		82559228-101	25mm
Rod	-1	82559229-102	14.3mm
		82559229-101	25mm
Seal washer	+4	82521069-101	
Rod packing	+1	82521067-102	
Rain cap	+1	82553334-101	
"O" ring	+1	82592235-596	
Washer	+1	82553318-101	

Model HA2D -> Model HA2R			
Part name	Q'ty	For stroke 14.3mm, 25mm	For stroke 38mm
Seal washers	+2	82521069-101	82521069-101
Rod packing	+1	82521067-101	82521067-101
Rod unit	+1	82521431-101 (14.3mm)	82521431-103
		82521431-102 (25mm)	
Rain cap	+1	82553334-101	82553334-101
Rod	(-1)	82521427-101 (14.3mm)	82521427-103
		82521427-102 (25mm)	

Model HA3D -> Model HA3R				
Part name	Q'ty	For stroke 14.3mm	For stroke 25mm, 38mm	For stroke 38mm
Seal washers	+2	82521069-102	82521069-102	82521069-102
Rod packing	+1	82521067-102	82521067-102	82521067-102
Rod unit	+1	82521431-201	82521431-202 (25mm)	82521431-204
			82521431-203 (38mm)	
Rain cap	+1	82553334-101	82553334-101	82553334-101
Rod	(-1)	82521428-101	82521428-102 (25mm)	82521428-104
			82521428-103 (38mm)	

Model HA4D -> Model HA4R			
Part name	Q'ty	For stroke 25mm	For stroke 38mm, 50mm, 75mm
Seal washers	+2	82521069-103	82521069-103
Rod packing	+1	82521067-103	82521067-103
Rod unit	+1	82521431-302	82521431-303
Rain unit	(-1)	82521429-102	82521429-103 (38mm)
			82521429-104 (50mm)
			82521429-105 (75mm)
Rain cap	+1	82553334-101	82553334-101
Flat washers	(-2)	82592131-201	82592131-201

Table 6-2. To Convert the Reverse Action Type into the Direct Action Type

Model PSA1R -> Model PSA1D			
Parts name	Q'ty		
Rod unite	+1	82559229-102	14.3mm
		82559229-101	25mm
Rod	-1	82559228-102	14.3mm
		82559228-101	25mm
Seal washer	-4	82521069-101	
Rod packing	-1	82521067-102	
Rain cap	-1	82553334-101	
"O" ring	-1	82592235-596	
Washer	+1	82553318-101	

Model HA2R -> Model HA2D			
Part name	Q'ty	For stroke 14.3mm, 25mm	For stroke 38mm
Seal washers	(-2)	82521069-101	82521069-101
Rod packing	(-1)	82521067-101	82521067-101
Rod unit	+1	82521427-101 (14.3mm)	82521427-103
		82521427-102 (25mm)	
Rod	(-1)	82521431-101 (14.3mm)	82521431-103
		82521431-102 (25mm)	
Rain cap	(-1)	82553334-101	82553334-101

Model HA3R -> Model HA3D				
Part name	Q'ty	For stroke 14.3mm	For stroke 25mm, 38mm	For stroke 50mm
Seal washers	(-2)	82521069-102	82521069-102	82521069-102
Rod packing	(-1)	82521067-102	82521067-102	82521067-102
Rod unit	+1	82521428-101	82521428-102 (25mm)	82521428-104
			82521428-103 (38mm)	
Rod	(-1)	82521431-201	82521431-202 (25mm)	82521431-204
			82521202-203 (38mm)	
Rain cap	(-1)	82553334-104	82553334-104	82553334-104

Model HA4R -> Model HA4D			
Part name	Q' ty	For stroke 25mm	For stroke 38mm, 50mm, 75mm
Seal washers	(-2)	82521069-103	82521069-103
Flat washers	+2	82592131-201	82592131-201
Rod packing	(-1)	82521067-103	82521067-103
Rod unit	(-1)	82521431-302	82521431-303
Rod	+1	82521429-102	82521429-103 (38mm)
			82521429-104 (50mm)
			82521429-105 (75mm)
Rain cap	(-1)	82553334-104	82553334-104

For the conversion procedure, refer to “Disassembly and Assembly”

## 6-2. Stroke and range spring change

As a general rule it is most recommendable to prepare separate actuators for different strokes and spring ranges to avoid modifications. However, modifications can be done by using the parts mentioned below.

Of Models HA2 and HA3, there are two different diameters of bonnet connection sections. For these models, note the following:

Of Model HA2, modification for change between read stroke of 14.3 or 25mm and that of 38mm cannot be done.

Of Model HA2, modification for change between rated stroke of 25 or 38mm and that of 50mm cannot be done.

Table 6-3. Parts Required for Respective Stroke Ranges

Note: spring force is equivalent to air pressure(kPa{kgf/cm<sup>2</sup>})

Actuator model		PSA1		
Part name		Q'ty	For Stroke 14.3mm	For Stroke 25mm
Scale plate		1	82559230-102	82559230-101
Spring	20-98{0.2-1.0}	4	82521340-101	82521340-104
	80-240{0.8-2.4}	4	82521340-102	82521340-103
Rod unit	R (Reverse action)	1	82559228-102	82559228-101
	D (Direct action)	1	82559229-102	82559229-101
Washer		1	82553318-101	82553318-101

Actuator model		HA2			
Part name		Q'ty	For Stroke 14.3mm	For Stroke 25mm	For Stroke 38mm
Scale plate		1	80225032-164	80225032-464	82554022-103
Spring	20-98{0.2-1.0}	4	82521205-101	82521205-103	82521208-102
	80-240{0.8-2.4}	4	82521205-102	82521208-101	82521208-103 82521208-104
Rod unit	R (Reverse action)	1	82521431-101	82521431-102	82521431-103
	D (Direct action)	1	82521427-101	82521427-102	82521427-103

Actuator model		HA3		
Part name		Q'ty	For Stroke 25mm	For Stroke 38mm
Scale plate		1	80225032-464	82554022-103
Spring	20-98{0.2-0.1}	8	82521206-101	82521206-103
	80-240{0.8-2.4}	8	82521206-102	82521209-101
Rod unit	R (Reverse action)	1	82521431-202	82521431-203
	D (Direct action)	1	82521428-102	82521428-103

Actuator model		HA4				
Part name		Q'ty	For Stroke 25mm	For Stroke 38mm	For Stroke 50mm	For Stroke 75mm
Scale plate		1	80225032-464	82554022-103	82521424-102	80224425-103
Spring	20-98{0.2-0.1}	8	82521244-104	82521207-101	82521207-102	82521210-103
	80-240{0.8-2.4}	8	82521244-106	82521210-101	82521210-102	82827929-101* 82827930-101*
Rod unit	R (Reverse action)	1	82521429-102	82521429-103	82521429-104	82521431-303
	D (Direct action)	1	82521431-302	82521431-303	82521431-303	82521429-105

\* : The quantity of springs is 8 set, with 2 springs for each set, or total 16 springs.

### Color Codes and Dimensions of the Springs of Model HA Actuators

The color codes and dimensions of the springs of Model HA Actuators are as shown in the following table. The color codes may help you confirm springs when disassembling and assembling actuators for modification or other purpose.

Table 6-4. Color Codes and Dimensions of Springs

Rated stroke	Actuator model		PSA1	HA2	HA3	HA4
	Range					
14.3	20-98 {0.2-1.0}	Red 64.6	Red 86	Yellow and Green 99.2		
	80-240 {0.8-2.4}	Blue 69.8	Blue 90	Red and Green 103.6		
25	20-98 {0.2-1.0}	Green 68.7	Yellow 91.4	Red 99.3	Yellow and Green 148.1	
	80-240 {0.8-2.4}	Purple 78.8	Brown 99	Blue 107	Red and Green 155.3	
38	20-98 {0.2-1.0}		Green 95	Yellow 102.9	Red 152.8	
	80-240 {0.8-2.4}		Purple 107	Brown 114.9	Blue 163.7	
50	20-98 {0.2-1.0}			Green 106.5	Yellow 156.3	
	80-240 {0.8-2.4}			Purple 122.2	Brown 170.6	
75	20-98 {0.2-1.0}				Green 163.4	
	80-240 {0.8-2.4}				White NOTE 1 182, 186.7 *	

- Note: 1. Each set is comprised of two springs.  
 2. "0.2-1.0" and "0.8-2.4" are spring forces corresponding to air pressures in the unit of kPa{kgf/cm<sup>2</sup>}.  
 3. The dimensions indicated are free lengths of springs.





# Chapter 7. Instructions for Top Handwheel of Actuator

## 7-1. Model PSA1 actuator

### 7-1-1. Operating instructions

To manually operate the actuator, refer to Figure 7-1 and Figure 7-2 and proceed as follows:

- (1) Loosen the lock nut of the handwheel and turn the handwheel in the direction indicated by the corresponding arrowhead mark.

As you turn the handwheel clockwise, the actuator stem moves downward regardless of whether the actuator is of the direct action type or reverse action type.

The handwheel bears the “SHUT” mark to indicate that the valve is closed as the handwheel is turned clockwise and the “OPEN” mark to indicate that the valve is made open as the handwheel is turned counterclockwise.

- (2) For automatic operation of the actuator, fully raise the handwheel if the actuator is of the direct action type or fully lower the handwheel if the actuator is of reverse action type, and then tighten the lock nut to secure the handwheel in such position.

Precautions: If you forcefully turn the handwheel after it has reached the mechanical stop position, the valve stem may be damaged. Do not turn the handwheel with forces larger than 160N {16 kgf} at the outermost periphery of the handwheel.

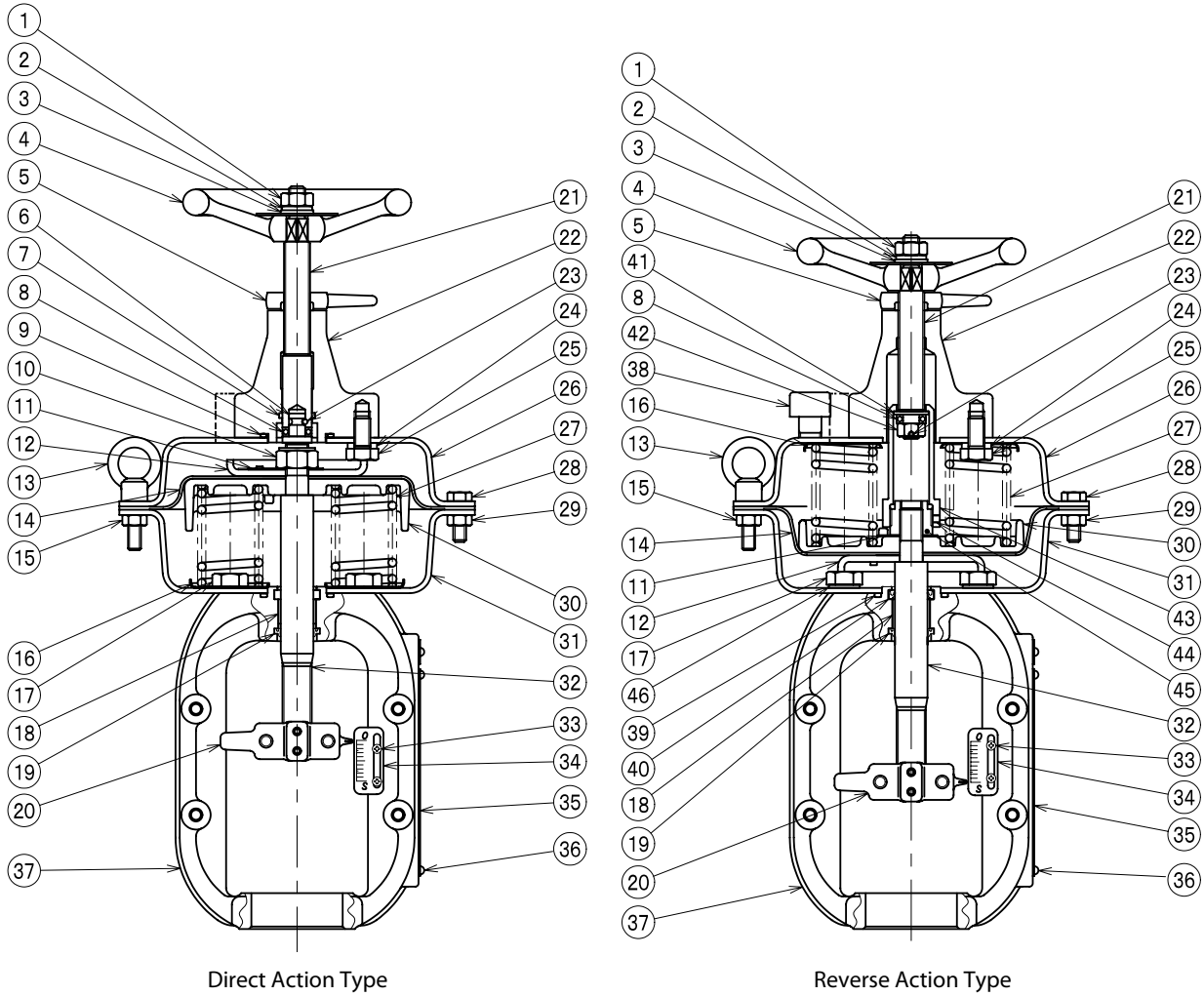

No.	Parts Name
1	Hex Nut
2	Spring Washer
3	Washer
4	Handwheel
5	Lock Nut
6	Washer
7	O-Ring
8	Bearing
9	O-Ring
10	Nut
11	Washer
12	Diaphragm Retainer
13	Eye Bolt
14	Diaphragm
15	Hex Nut
16	Spring Plate

No.	Parts Name
17	Hex Bolt
18	Bushing
19	Dust Seal
20	Stem Connector
21	Screw Shaft
22	Housing
23	Spring Pin
24	Seal Washer
25	Hex Bolt
26	Diaphragm Case(Top)
27	Spring
28	Hex Bolt
29	Hex Nut
30	Diaphragm Plate
31	Diaphragm Case (Bottom)

No.	Parts Name
32	Rod
33	Truss Screw
34	Scale Plate
35	Name Plate
36	Drive Screw
37	yoke
38	Rain Cap
39	O-Ring
40	Rod Packing
41	Bearing Washer
42	Nut
43	Bearing Case
44	Setscrew
45	Connection
46	Seal Washer

Figure 7-1 Model PSA1 Actuator with Top Handwheel

## 7-1-2. Disassembly and assembly of top handwheel

To disassemble or assemble the top handwheel, refer to Figure 7-1 through Figure 7-4 and proceed as described in this section. For disassembly work, keep the actuator in the vertical attitude.

### (a) Direct Action Type

- (1) Disconnect the air piping.
- (2) Set the handwheel shaft in the automatic operation position (fully raise the handwheel shaft).
- (3) Remove the top diaphragm case. When doing this, loosen the pair of eyebolts uniformly and alternately, after removing all other clamping-bolts of the diaphragm case.
- (4) Sufficiently insert the handwheel shaft by turning it and then remove the handwheel and the lock nut. Insert the shaft further and then remove the screw shaft from the housing.
- (5) Remove the O-ring.

To assemble the top handwheel, follow the disassembly procedure in the reverse order.

### (b) Reverse Action Type

- (1) Disconnect the air piping.
- (2) Set the handwheel shaft in the automatic operation position (fully lower the handwheel shaft).
- (3) Remove the handwheel and the lock nut. Insert the shaft into the housing by means of the threading until the threaded sections are disengaged.
- (4) Remove the top diaphragm case. When doing this, loosen the pair of eyebolts uniformly and alternately, after removing all other clamping-bolts of the diaphragm case.
- (5) Remove the housing by loosening its clamping-screw.
- (6) Remove the setscrew and then remove the bearing case.
- (7) Remove the spring pin and then remove the castle nut.
- (8) Remove the bearing retainer and then remove the bearing.

To assemble the top handwheel, follow the disassembly procedure in the reverse order.

### (c) Inspection After Assembly

- (1) Check that the handwheel turns smoothly for the full stroke.
- (2) For the direct action type of actuator, check by means of soapsuds that there is no air leak from the connecting section of the top diaphragm case.



## 7-2. Model HA2, HA3, or HA4 actuator

### 7-2-1. Operating instructions

To manually operate the actuator, refer to Figure 7-4 through Figure 7-7 and proceed as follows:

- (1) First, loosen the lock nut (which has a bar-shape handle and which locks the handwheel, and turn the handwheel in the direction indicated by the corresponding arrowhead mark.  
As you turn the handwheel clockwise, the actuator stem moves downward regardless of whether the actuator is of the direct action type or reverse action type. The handwheel bears the "SHUT" mark to indicate that the valve is closed as the handwheel is turned clockwise and the "OPEN" mark to indicate that the valve is made open as the handwheel is turned counterclockwise.
- (2) For automatic operation of the actuator, fully raise the handwheel if the actuator is of the direct action type or fully lower the handwheel if the actuator is of the reverse action type, and then tighten the lock nut to secure the handwheel in such position.

Precautions: If you forcefully turn the handwheel after it has reached the mechanical stop position, the valve stem may be damaged. Do not turn the handwheel with forces larger than the below-mentioned limits.

Model HA2: 190N {19 kgf}

Model HA3: 260N {26 kgf}

Model HA4: 410N {41 kgf}

(at the outermost periphery of the handwheel)

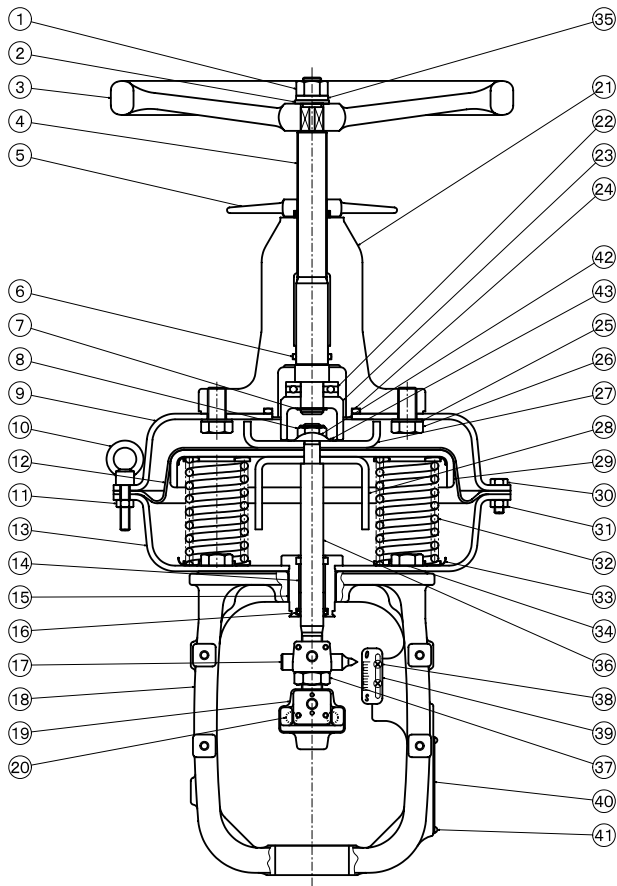

No.	Parts Name
1	Hex Nut
2	Washer
3	Handwheel
4	Screw Shaft
5	Lock Nut
6	O-Ring
7	C type Retaining Ring
8	Nut
9	Diaphragm Case(Top)
10	Eye Bolt
11	Hex Nut
12	Diaphragm
13	Diaphragm Case(Bottom)
14	Bushing
15	Bearing
16	Dust Seal
17	Pointer
18	Yoke
19	Stem Connector
20	Hex Bolt
21	Housing
22	Bearing
23	Spring Retainer
24	O-Ring
25	Seal Washer
26	Hex Bolt
27	Diaphragm Retainer
28	Stopper
29	Diaphragm Plate
30	Hex Bolt
31	Hex Nut
32	Spring
33	Spring Plate
34	Hex Bolt
35	Spring Washer
36	Rod
37	Lock Nut
38	Truss Screw, Spring Washer Nut, or Speed Nut
39	Scale Plate
40	Name Plate
41	Drive Screw
42	Washer
43	Tapping Screw

Figure 7-4 Model HA2/3 Actuator with Top Handwheel (Direct Action Type)

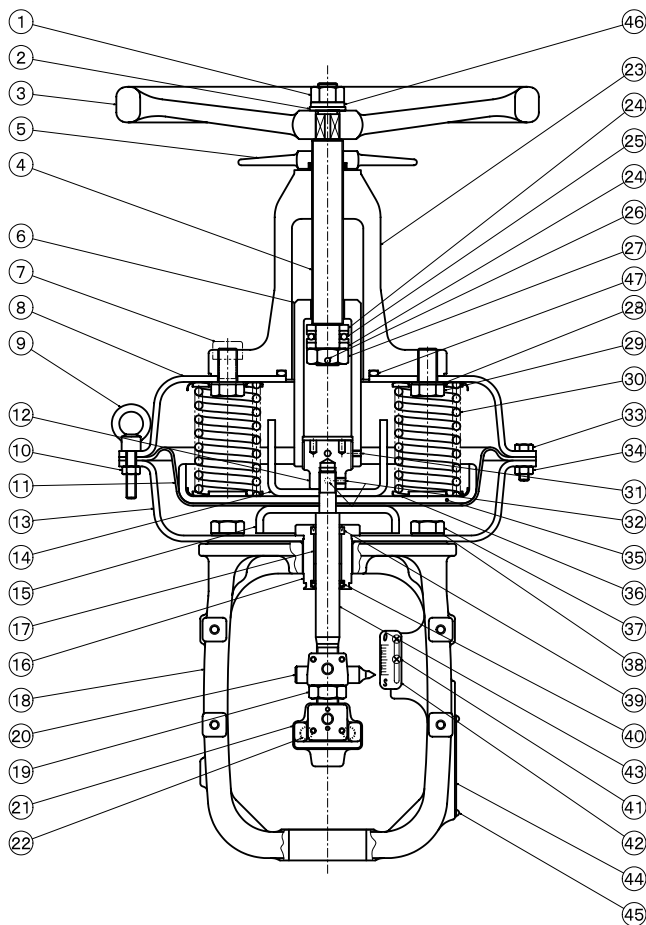

No.	Parts Name
1	Hex Nut
2	Washer
3	Handwheel
4	Screw Shaft
5	Lock Nut
6	Bearing Case
7	Rain Cap
8	Diaphragm Case(Top)
9	Eye Bolt
10	Hex Nut
11	Diaphragm
12	Connection
13	Diaphragm Case(Bottom)
14	Stopper
15	Diaphragm Retainer
16	Bearing
17	Bushing
18	Yoke
19	Lock Nut
20	Pointer
21	Stem Connector
22	Hex Bolt
23	Housing
24	Bearing Washer
25	Bearing
26	Cotter Pin
27	Nut
28	Seal Washer
29	Hex Bolt
30	Spring
31	Setscrew
32	Setscrew
33	Hex Bolt
34	Hex Nut
35	Diaphragm Plate
36	Spring Plate
37	Hex Bolt
38	Seal Washer
39	Rod Packing
40	Dust Seal
41	Truss Screw, Spring Washer Nut, or Speed Nut
42	Scale Plate
43	Rod
44	Name Plate
45	Drive Screw
46	Spring Washer
47	O-Ring

Figure 7-5 Model HA2/3 Actuator with Top Handwheel (Reverse Action Type)

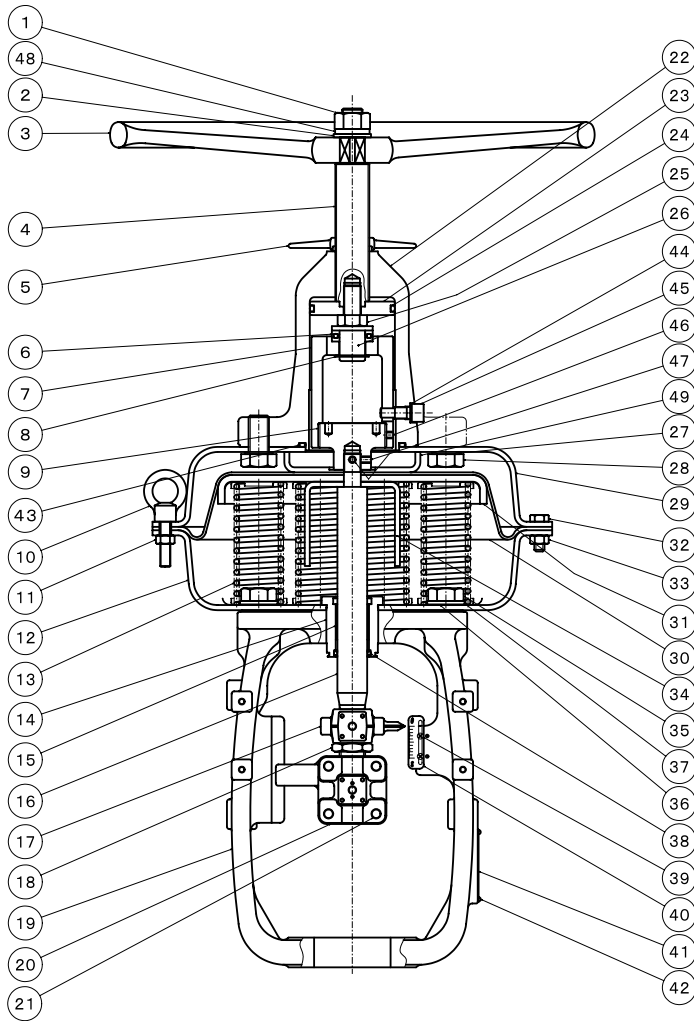

No.	Parts Name
1	Hex Nut
2	Washer
3	Handwheel
4	Screw Shaft
5	Lock Nut
6	Bearing Case
7	Rain Cap
8	Diaphragm Case(Top)
9	Eye Bolt
10	Hex Nut
11	Diaphragm
12	Diaphragm Case(Bottom)
13	Stopper
14	Connection
15	Diaphragm Retainer
16	Bearing
17	Bushing
18	Yoke
19	Rod
20	Pointer
21	Stem Connector
22	Hex Bolt
23	Housing
24	Bearing Washer
25	Bearing
26	Cotter Pin
27	Nut
28	Seal Washer
29	Hex Bolt
30	Spring
31	Setscrew
32	Hex Bolt
33	Hex Nut
34	Setscrew
35	Diaphragm Plate
36	Spring Plate
37	Hex Bolt
38	Seal Washer
39	Rod Packing
40	Dust Seal
41	Truss Screw, Spring Washer Nut, or Speed Nut
42	Scale Plate
43	Lock Nut
44	Name Plate
45	Drive Screw
46	Key Bolt
47	Spring Washer
48	O-Ring

Figure 7-6 Model HA4 Actuator with Top Handwheel (Direct Action Type)



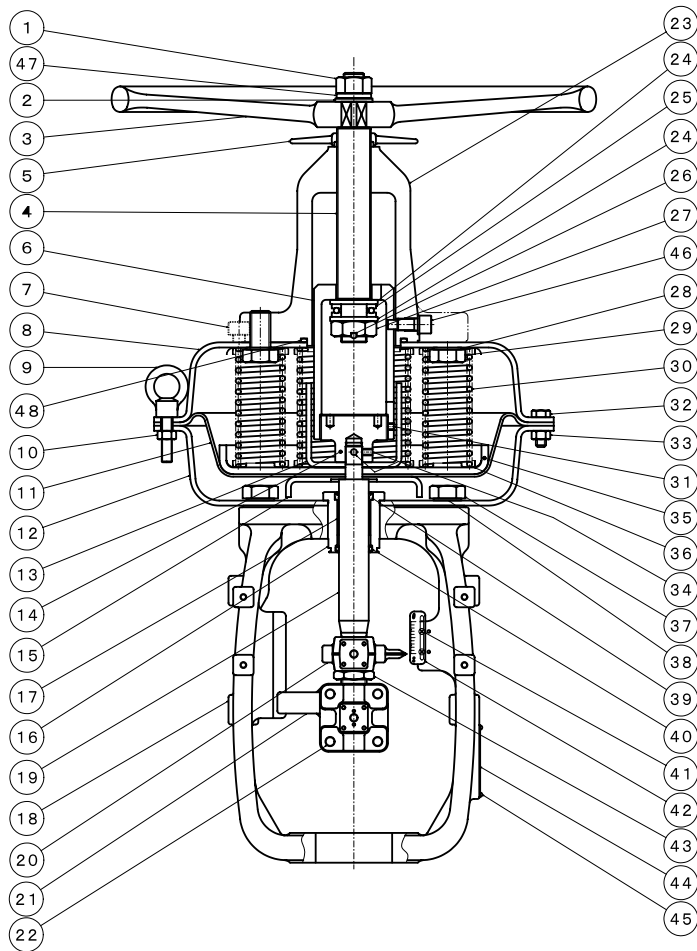

No.	Parts Name
1	Nut
2	Washer
3	Handwheel
4	Lock Nut
5	Screw Shaft
6	Bearing Case
7	Cap
8	Diaphragm Case(Top)
9	Eyebolt
10	Nut
11	Through Bolt
12	Diaphragm
13	Diaphragm Case(Bottom)
14	Stopper
15	Connector
16	Diaphragm Retainer
17	Bearing
18	Bushing
19	Yoke
20	Rod
21	Pointer
22	Stem Connector
23	Stem Connector Bolt
24	Housing
25	Washer
26	Bearing
27	Bearing
28	Cotter Pin
29	Seal Washer
30	Bolt
31	Coil Spring
32	Setscrew
33	Bolt
34	Nut
35	Setscrew
36	Diaphragm Plate
37	Spring Plate
38	Bolt
39	Seal Washer
40	Packing
41	Dust Seal
42	Truss Screw, Speed Nut
43	Scale
44	Lock Nut
45	Nameplate
46	Drive Screw
47	Keybolt
48	Spring Washer
49	O-Ring

Figure 7-7 Model HA4 Actuator with Top Handwheel (Reverse Action Type)

## 7-2-2. Disassembly and assembly of top handwheel

To disassemble or assemble the top handwheel, refer to Figure 7-4 through Figure 7-9 and proceed as described in this section. For disassembly and assembly work, keep the actuator in the vertical attitude.

### (a) Direct Action Type

- (1) Disconnect the air piping.
- (2) Set the handwheel shaft in the automatic operation position (fully raise the handwheel shaft).
- (3) Remove the top diaphragm case. When doing this, loosen the pair of eyebolts uniformly and alternately, after removing all other clamping-bolts of the diaphragm case.
- (4) Sufficiently insert the handle shaft by turning it and then remove the handwheel and the lock nut. Insert the shaft further and then remove the screw shaft from the housing.
- (5) Remove the O-ring.

To assemble the top handwheel, follow the disassembly procedure in the reverse order.

### (b) Reverse Action Type

- (1) Disconnect the air piping.
- (2) Set the handwheel shaft in the automatic operation position (fully lower the handwheel shaft).
- (3) Remove the handwheel and the lock nut. Insert the shaft into the housing by means of the threading until the threading sections are disengaged.
- (4) Remove the top diaphragm case. When doing this, loosen the pair of eyebolts uniformly and alternately, after removing all other clamping-bolts of the diaphragm use.
- (5) Remove the housing by loosening its clamping-screws.
- (6) Remove the setscrew and then remove the bearing case.
- (7) Remove the pin and then remove the castle nut.
- (8) Remove the bearing retainer and then remove the bearing.

To assemble the top handwheel, follow the disassembly procedure in the reverse order.

### (c) Inspection After Assembly

- (1) Check that the handwheel turns smoothly for the full stroke.
- (2) For the direct action type of actuator, check by means of soapsuds that there is no air leak from the connecting sections of the housing and top diaphragm case.

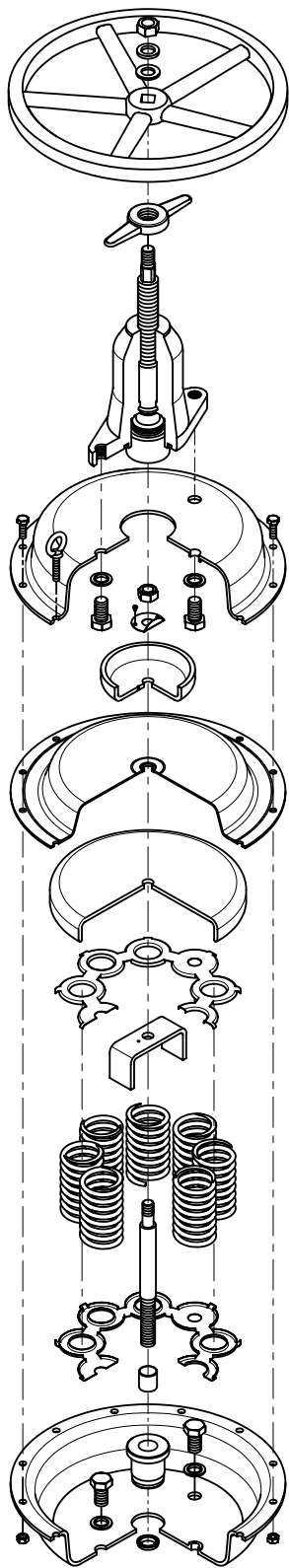

Figure 7-8 Direct Action Type

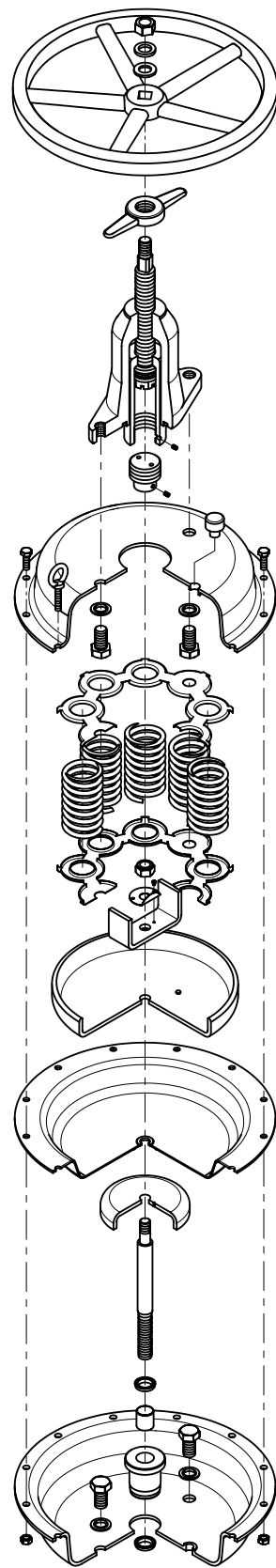

Figure 7-9 Reverse Action Type



## Chapter 8. Instructions for Side Handwheel of Actuator

As you turn the handwheel clockwise, the actuator stem moves downward regardless of whether the actuator is of the direct action type or reverse action type. The handwheel bears the "SHUT" mark to indicate that the valve is closed as the handwheel is tuned clockwise and the "OPEN" mark to indicate that the valve is made open as the handwheel is tuned counterclockwise.

### 8-1. Installation procedure

To install the side handwheel, refer to Figure 8-1 and proceed as follows:

- (1) Prepare a manual operation kit (a side handwheel set and its mounting accessories).  
To install the handwheel, no machining or other physical processing on the actuator is necessary.
- (2) By turning the handwheel, set the pointer of the operation nut at the AUTO position.
- (3) Loosen the bolt (item number 6 as-show in Figure 8-1) and widen the distance between levers.
- (4) Install the handwheel on the mounting pad at the back of the actuator, with the mounting-bolts.
- (5) Engage the holes at the end of two levers to the pointer boss and engage those of the other ends to the boss of the operation nut, and then tighten the bolt.
- (6) When the control valve is in the automatic mode of operation, set the pointer of the operation nut at the AUTO position and keep the handwheel locked.

### 8-2. Operating instructions

- (1) To manually operate the actuator, remove the handwheel lock (the fork-shaped component) which locks the handwheel and turn the handwheel in the direction indicated by the corresponding arrowhead mark.
- (2) To return to the automatic operation, turn the handwheel so that the pointer of the operation nut is set at the AUTO position and then apply the handwheel lock.

Precautions: If you forcefully turn the handwheel after it has reached the mechanical stop position, the valve stem may be damaged. Do not turn the handwheel with forces larger than the below-mentioned limits.

Model PSA1:	80 N {8 kgf}
Model HA2:	190 N {19 kgf}
Model HA3:	290 N {29 kgf}
Model HA4:	460 N {46 kgf}

(at the outermost periphery of the handwheel)

### **8-3. Disassembly of side assembly of side handwheel**

Before starting disassembly, check that the pointer is set at the AUTO position. (Refer to Figure 8-1)

- (1) Loosen the bolt 6 which connects the levers 2 and then disengage the levers from the pointer.
- (2) Undo the mounting-bolts 1 of the side handwheel unit and detach it from the actuator.
- (3) Remove the lock nut of the handwheel and then remove the handwheel.
- (4) Loosen the bolt 8 of the bearing holder and then remove the feed shaft 7.

To assemble the side handwheel, refer to Figure 8-1 and follow the disassembly procedure in the reverse order.

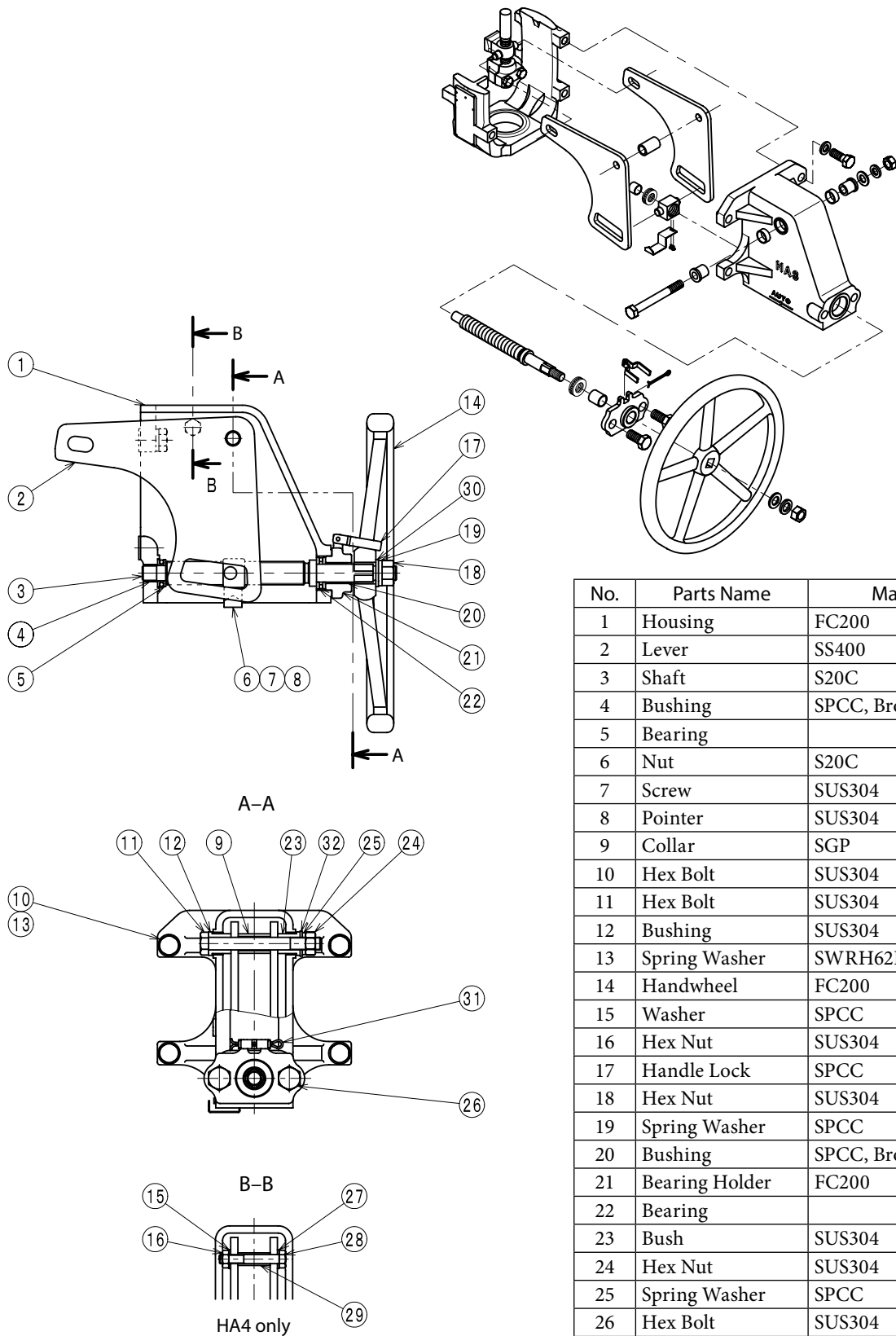

No.	Parts Name	Material
1	Housing	FC200
2	Lever	SS400
3	Shaft	S20C
4	Bushing	SPCC, Bronz, PTFE
5	Bearing	
6	Nut	S20C
7	Screw	SUS304
8	Pointer	SUS304
9	Collar	SGP
10	Hex Bolt	SUS304
11	Hex Bolt	SUS304
12	Bushing	SUS304
13	Spring Washer	SWRH62B, SUS304
14	Handwheel	FC200
15	Washer	SPCC
16	Hex Nut	SUS304
17	Handle Lock	SPCC
18	Hex Nut	SUS304
19	Spring Washer	SPCC
20	Bushing	SPCC, Bronz, PTFE
21	Bearing Holder	FC200
22	Bearing	
23	Bush	SUS304
24	Hex Nut	SUS304
25	Spring Washer	SPCC
26	Hex Bolt	SUS304
27	Washer	SPCC
28	Hex Bolt	SUS304
29	Collar	SGP
30	Washer	SWRH62B, SUS304
31	Pin	SUS304
32	Washer	SWRH62B, SUS304

Figure 8-1 View of Side-Handwheel





# **Chapter 9. Instructions for Bellows Sealed Type of Control Valves**

The bellows sealed type of control valves differ from other control valves in that the former employ a bellows for seal. This chapter covers primarily the particular items related to the bellows sealed type of control valves.

Note: The bellows seal assembly should be replaced periodically. The frequency of replacements depends on the conditions of use. When handling a mechanism which has a bellows seal assembly, exercise care so that the mechanism is not twisted. Note that the bellows is not highly resistant against torsion.

## 9-1. Structures (Model HCB Control Valves)

The structures of Model HCB Control Valves are shown in Figure 9-1.

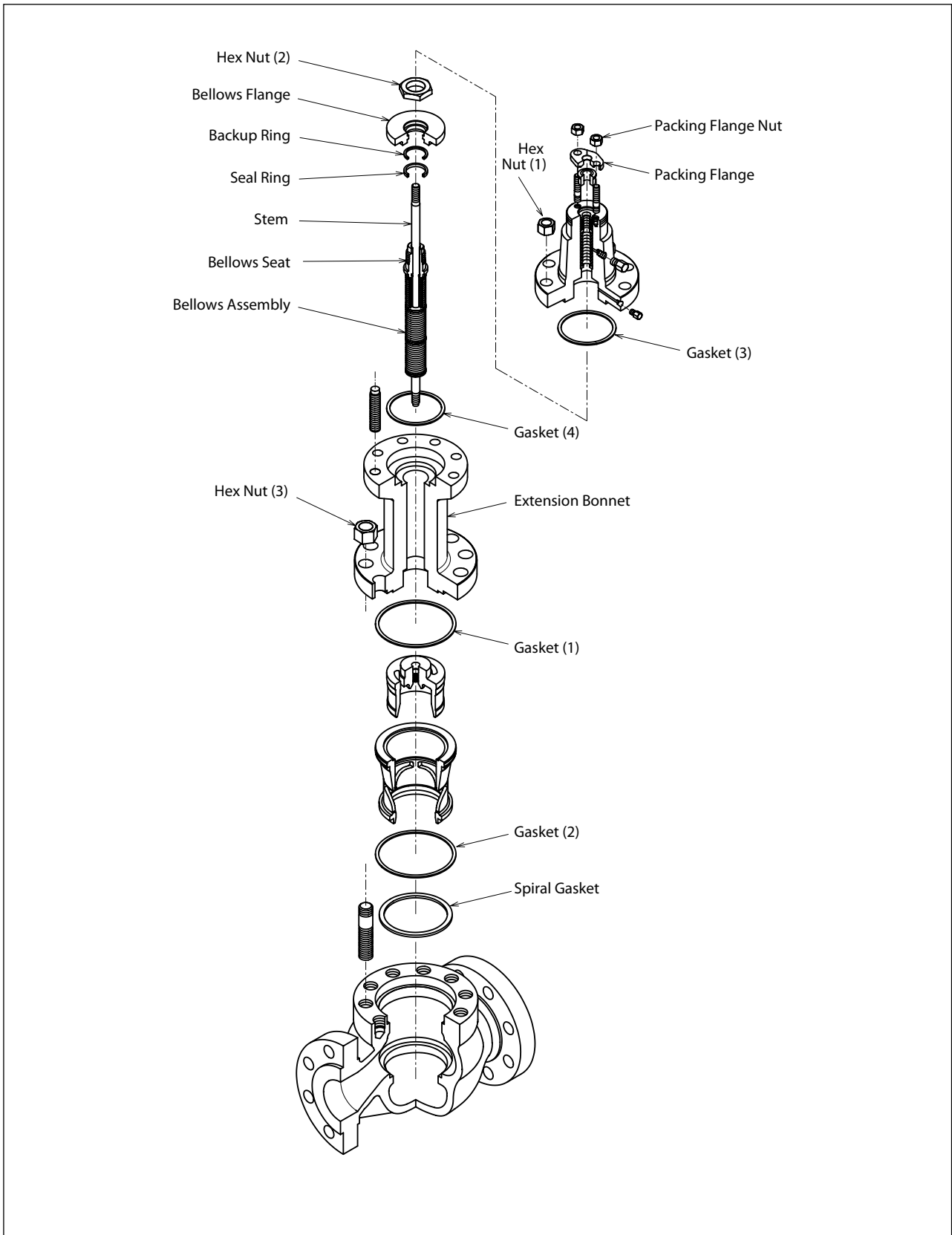

Figure 9-1 Model HCB Control Valve

## 9-2. Disassembly and assembly

- (1) Detach the actuator from the valve as described in Section 4.1.
- (2) Loosen the packing flange nut.
- (3) Loosen the hex nut (1) of the bonnet, using the wrench.
- (4) Raise the bonnet and remove the gasket (3).  
Note: When raising the bonnet, press down the stem so that it will not come up together with the bonnet.
- (5) Remove the hex nut (2) which fixes the bellows flange and bellows seat.  
Note: When loosening the nut, hold stationary the bellows seat so that no unreasonably large torsion is applied to the bellows, which is not highly resistant against torsion.
- (6) Remove the bellows flange and gasket (4).  
Note: The bellows seat can be readily detached by lightly hitting its top.  
(The most effective method is to hit it by passing a pipe into the stem.)
- (7) Remove the hex nut (3) which fixes the extension, by using a wrench. Detach the extension from the valve body.
- (8) Remove the stem.  
Note: The stem section has a valve plug, bellows seat and bellows assembly, welded together.
- (9) Remove the gasket (1) and pull up the cage. If the cage does not come up easily, use the special tool (optional).
- (10) Remove the gasket (2) and the spiral gasket.  
Note: Of the split cage type of valve, the seat ring is fixed to the valve body by threading. To remove the seat ring, the special tool (optional) is needed.

For assembly of the control valve, follow the disassembly procedure in the reverse order.



# Chapter 10. Azbil Low Emission standard-compliant gland packing

## 10-1. Overview

Azbil low emission gland packing is a gland structure that employs a Live Load structure to its performance for a long period of time. In order to meet the emission regulations for Volatile Organic Compounds (VOC) required by the U.S. Clean Air Act Amendments (CAAA), we confirmed that the amount of gland leakage was not more than 500 ppm in terms of the atmospheric concentration of the equivalent methane value on the basis of Azbil Corporation's own evaluation criteria. \* For the structure of the gland, refer to the structural drawing of Azbil low emission gland packing in Fig. 10-1.

\* In Japan and overseas as of October, 2005, there are no industry standards that lay down any evaluation method for gland leakage.

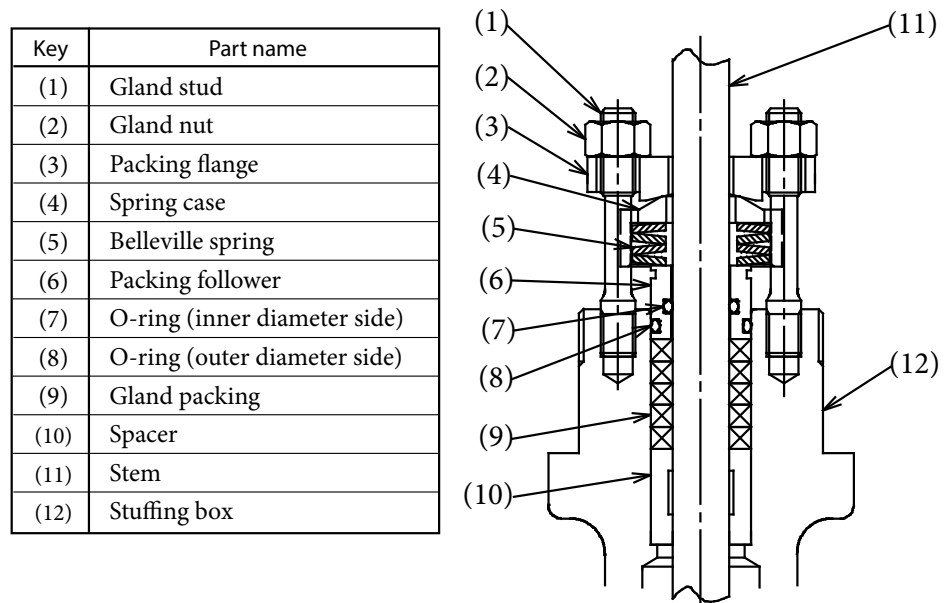

Fig. 10-1. Structural drawing of Azbil low emission gland packing

## 10-2. Structure

The gland packing P4519 for use in Azbil low emission gland packing is woven PTFE yarn with carbon fiber core. This gland packing provides asbestos-free properties in addition to low sliding friction and adaptability to heat cycles, and is adaptable to a wide range of fluids.

This gland packing is fastened with a Live Load structure comprised of Belleville springs. The Belleville springs are made to be tight compressing at the time of initial fastening. As a valve is operated, the seal performance of the gland packing becomes deteriorated because of strain release, but the restoring force of the Belleville springs automatically retightens it to maintain seal performance. The Belleville springs are installed in the spring case for the purposes of positioning and environmental protection. The loading conditions of the Belleville springs can be determined by checking a front window and scale marks of the spring case.

The set of parts can be added to an existing product without any change of its main body or actuator if it is an applicable control valve.

## 10-3. Installation into the gland

### 10-3-1. Preparation for installation

#### 1. Checking for the surface conditions of parts

If there is any flaw or the like on the surface of a part, the total amount of gland leakage may exceed a specified value because of fluid leakage from the periphery. For this reason, check the surface conditions of the following parts:

Table 10-1. Parts whose surface conditions need to be checked

Part name	Finding:	Assumption
Stem	<ul style="list-style-type: none"> <li>No flaws or defects, including scratches and dents</li> <li>No rust or corrosion</li> <li>The finished surface should be uniform over its entire area.</li> <li>No burrs</li> <li>Clean, without adhesion of any coating material, powdery material, or dirt</li> <li>When necessary, measures should be taken, such as cleaning with alcohol.</li> </ul>	The total amount of gland leakage may exceed the specified value because of fluid leakage from the periphery of a flaw .
Stuffing box		
Both ends of the spacer		
Packing follower		
Packing contact surface O-ring groove		
Packing flange Gland nut contact surface	<ul style="list-style-type: none"> <li>No flaws, rust, or defects.</li> </ul>	The amount of gland leakage may exceed the specified value because of insufficient tightening.
Packing flange Entire surface Gland stud Gland nut		Damage to the control valve may be caused, and may lead to physical injury.

#### 2. Preparation of new parts

Be sure to prepare new parts at the time of the first installation or reinstallation of the following parts.

Table 10-2. Parts that need to be renewed

Part name	Finding	Assumption
Gland packing	No flaws, coating materials, or dirt on the surface	The amount of leakage may exceed the specified value because of fluid leakage from the periphery of a flaw or the like.
Belleville spring		The amount of gland leakage may exceed the specified value in a short period of time because of overtightening or insufficient tightening.

### 3. Preparation of lubricating grease and anti-seize compound

Prepare proper amounts of lubricating grease and anti-seize compound indicated in the following table. (Equivalents also can be used.)

Table 10-3. Lubricating grease and anti-seize compound

Product name	Area to be coated
Silicone grease G40M made by Shin-Etsu Chemical Co., Ltd.	Entire surface of the gland packing
Plastilube No. 3 made by Sulflo, Inc., in the U.S.	Entire surface of the backup O-rings
Anti-seize compound Never-Seez made by Bostik, Inc., in the U.S.	Surface of the threads of the gland studs
	Bearing surface of the gland nuts

## 10-3-2. Start of installation

### 1. Coating with lubricating grease

Step 1: Apply a thin film (not more than 0.3 mm thick) of the grease indicated in Table 10-3 [G40M made by Shin-Etsu Chemical Co., Ltd.] to the entire surface of all the gland packing.

Step 2: Apply the grease indicated in Table 10-3 [Plastilube No. 3 made by Sulflo, Inc., in the U.S.] to each of the two backup O-rings on the inner diameter side and the outer diameter side of the packing follower.

### 2. Installation of parts

#### Step 1:

With reference to Fig. 10-2, check the direction of the gland studs. After applying the anti-seize compound indicated in Table 10-3 [Never-Seez made by Bostik, Inc., in the U.S.] to the surface of the threads, install them into the stuffing box.

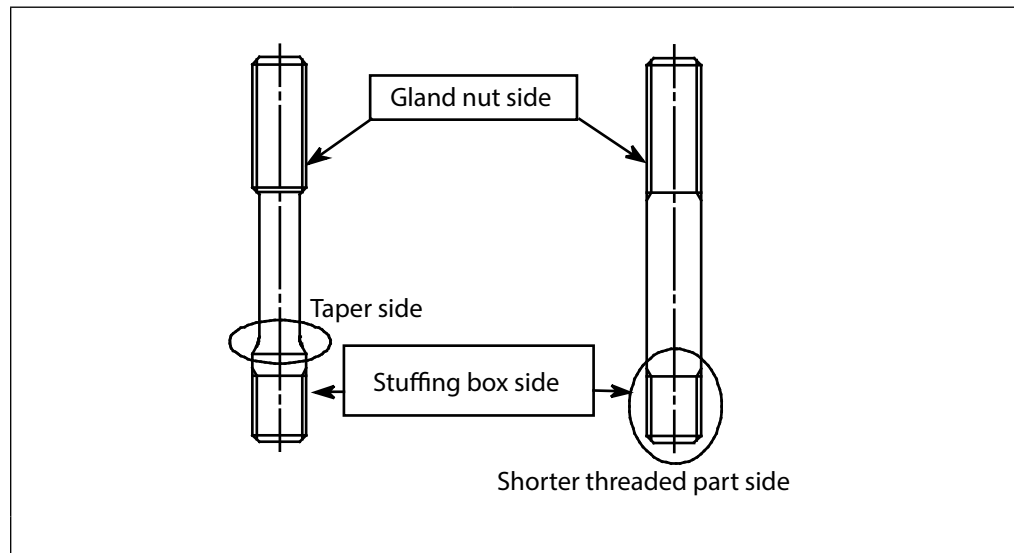

Fig. 10-2. Direction of the gland studs

**Step 2:**

Being careful not to damage the surface of the stem, install the spacer first.

**Step 3:**

Next, install one piece of the gland packing. Be sure to note how to open indicated in Fig.10-3. Insert it tightly with a pipe or the like. Finally, press it lightly.

Insert the second and subsequent pieces, with the gap position shifted by 180 degrees.

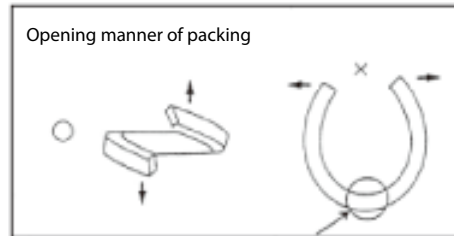

Fig. 10-3. How to handle gland packing

**Step 4:**

Next, check the direction of the packing follower. (See Fig. 10-1.) The outside O-ring side is the packing side.) Install it while being careful not to damage the surface of the stem.

**Step 5:**

With reference to Fig. 10-1, install the Belleville springs while being careful not to damage the surface of the stem.

**Step 6:**

With reference to Fig. 10-4, install the spring case in such a manner that two opposed side grooves are guided with the gland studs. (Two pairs of opposed side grooves are the same in dimension.) At the time of the installation, be careful not to damage the surface of the stem. Incidentally, when the Belleville springs are set in the spring case, they do not come into contact with the stem.

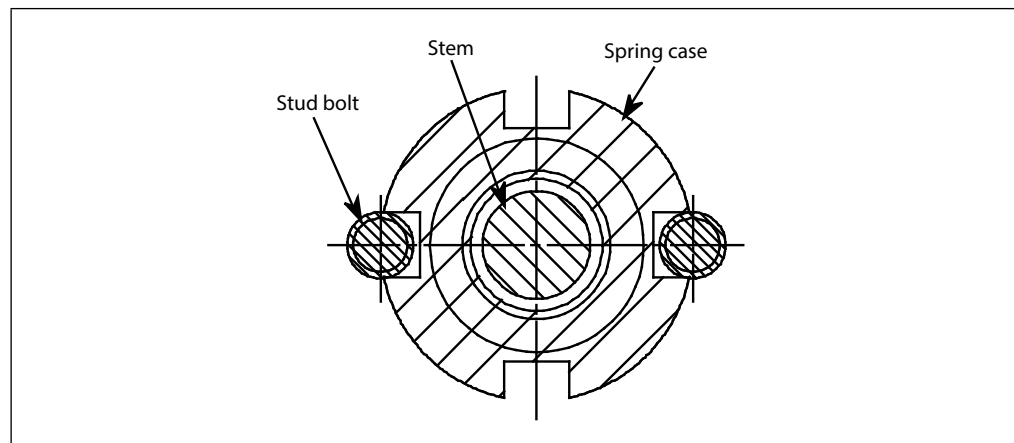

Fig. 10-4. Installation of the spring case Top view

**Step 7:**

Being careful not to damage the surface of the stem, install the packing flange.

**Step 8:**

After applying the anti-seize compound indicated in Table 10-3 [Never-Seez made by Bostik, Inc., in the U.S.] to the surface of the threads of the stud bolts and the bearing surface of the nuts, tighten them by hand.



### 3. Tightening

#### Step 1:

With reference to Fig. 10-5, check the position of the Belleville springs through the front window of the spring case. When the Belleville springs are set properly, the lower edge of the outer diameter of the lowest Belleville spring almost coincides with the lower scale mark of the spring case. (In some cases, it does not exactly coincide because of the dimensional tolerance of the Belleville springs.)

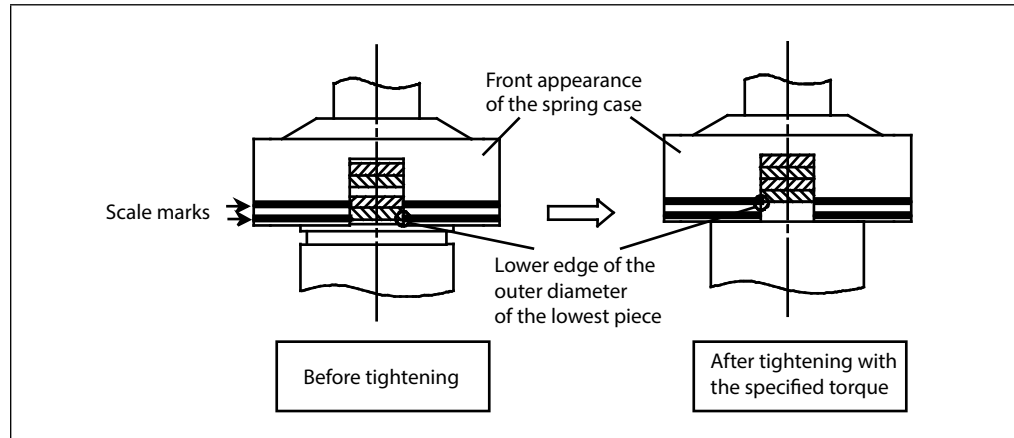

Fig. 10-5. Loading conditions of the Belleville springs

#### Step 2:

Tighten each of the right and left gland nuts by half a turn alternately to the specified torque. Table 10-4 shows the tightening torque.

If the tightening torque is less than the specified value, be aware that the amount of leakage may exceed the specified value because of insufficient tightening.

If the tightening torque is more than the specified value, be aware that the amount of leakage may exceed the specified value in a short period of time because of the accelerated wear of the gland packing, in addition to the increased sliding friction of the stem.

Table 10-4. Gland nut tightening torque (for PTFE yarn)

Actuator model	Stem size	Tightening torque
PSA1, HA2	$\phi$ 10 mm	8 to 10 N·m
HA2, HA3	$\phi$ 13 mm	13 to 16 N·m
HA3	$\phi$ 16 mm	22 to 26 N·m
HA4	$\phi$ 20 mm	29 to 35 N·m

### **10-3-3. Retightening**

In the following cases, retighten the gland nuts with the specified torque:

- a) At the time of an inspection before the installation of the control valve
- b) At the time of a test operation or start-up operation of the equipment
- c) In case the leakage amount of the gland exceeds the specified value during operation of the equipment.

If the leakage amount of the gland still exceeds the specified value after retightening, reinstall the complete set of gland parts. In addition, it is recommended that the gland packing and the Belleville springs be replaced with new parts.

## 10-4. Parts List

Part name	Actuator model	Stem size	Material	Part No.	Qty.		
Main packing	PSA1	φ10 mm	P4519	80255384-111	5		
Belleville spring			SUS304	82571710-101	4		
O-ring (small)			Viton	82592220-897	1		
O-ring (large)			Viton	82592221-897	1		
Stem connector			SCS13A	82557767-101	1		
Gland stud			SUS304	82559311-012	2		
Gland nut			SUS304	82592448-163	2		
Spring case			SUS304	82571708-101	1		
Packing follower			SUS304	82571711-101	1		
Packing follower for O-ring use			SUS304	82571715-101	1		
Spacer			SUS304	82555645-066	1		
Spacer for O-ring use			SUS304	82555645-566	1		
Main packing			HA2	φ10 mm	P4519	80255384-111	5
Belleville spring					SUS304	82571710-101	4
O-ring (small)	Viton	82592220-897			1		
O-ring (large)	Viton	82592221-897			1		
Stem connector	S20C/S25C	82520978-201			1		
Gland stud	SUS304	82559311-012			2		
Gland nut	SUS304	82592448-163			2		
Spring case	SUS304	82571708-101			1		
Packing follower	SUS304	82571711-101			1		
Packing follower for O-ring use	SUS304	82571715-101			1		
Spacer	SUS304	82555645-066			1		
Spacer for O-ring use	SUS304	82555645-566			1		
Main packing	HA2	φ13 mm			P4519	80255385-111	5
Belleville spring					SUS304	82559308-101	4
O-ring (small)			Viton	82592221-497	1		
O-ring (large)			Viton	82592222-297	1		
Stem connector			S20C/S25C	82520978-206	1		
Gland stud			SUS304	82571706-011	2		
Gland nut			SUS304	82592448-173	2		
Spring case			SUS304	82559309-101	1		
Packing follower			SUS304	82571712-101	1		
Packing follower for O-ring use			SUS304	82571716-101	1		
Spacer			SUS304	82555645-166	1		
Spacer for O-ring use			SUS304	82555645-666	1		
Main packing			HA3	φ13 mm	P4519	80255385-111	5
Belleville spring					SUS304	82559308-101	4
O-ring (small)	Viton	82592221-497			1		
O-ring (large)	Viton	82592222-297			1		
Stem connector	S20C/S25C	82571706-011			1		
Gland stud	SUS304	82571706-011			2		
Gland nut	SUS304	82592448-173			2		
Spring case	SUS304	82559309-101			1		
Packing follower	SUS304	82571712-101			1		
Packing follower for O-ring use	SUS304	82571716-101			1		
Spacer	SUS304	82555645-166			1		
Spacer for O-ring use	SUS304	82555645-666			1		

Part name	Actuator model	Stem size	Material	Part No.	Qty.
Main packing	HA3	φ16 mm	P4519	80255386-111	5
Belleville spring			SUS304	82559308-102	4
O-ring (small)			Viton	82592221-797	1
O-ring (large)			Viton	82592222-897	1
Stem connector			S20C/S25C	82521091-201	1
Gland stud			SUS304	82559312-011	2
Gland nut			SUS304	82592448-013	2
Spring case			SUS304	82559310-101	1
Packing follower			SUS304	82571713-101	1
Packing follower for O-ring use			SUS304	82571717-101	1
Spacer			SUS304	82555645-766	1
Spacer for O-ring use			SUS304	82555645-101	1
Main packing			HA4	φ20 mm	P4519
Belleville spring	SUS304	82571710-201			4
O-ring (small)	Viton	82592221-997			1
O-ring (large)	Viton	82592223-397			1
Stem connector	S20C/S25C	82551348-202			1
Gland stud	SUS304	82571707-011			2
Gland nut	SUS304	82592448-023			2
Spring case	SUS304	82571709-101			1
Packing follower	SUS304	82571714-101			1
Packing follower for O-ring use	SUS304	82571718-101			1
Spacer	SUS304	82555645-866			1
Spacer for O-ring use	SUS304	82555645-201			1

# Chapter 11. Certified ISO 15848-1 compliant low emission gland packing

## 11-1. Overview

Certified ISO 15848-1 low emission gland packing employs a live-loaded packing system to maintain valve seal performance for a long period of time. The gland packing system has acquired third-party certification for compliance with ISO15848-1, which is the international standard for low-emission performance of valves. For the structure of the gland, see Fig. 11-1 and Fig. 11-2.

No.	Name
(1)	Gland stud
(2)	Gland nut
(3)	Packing flange
(4)	Belleville spring
(5)	Packing follower
(6)	Carbon ring (P6210C2FS)
(7)	Adapter packing (P6720)
(8)	Main packing (P4519)
(9)	Spacer
(10)	Stem
(11)	O-ring for inner side of packing follower (optional)
(12)	O-ring for outer side of packing follower (optional)
(13)	Stuffing box

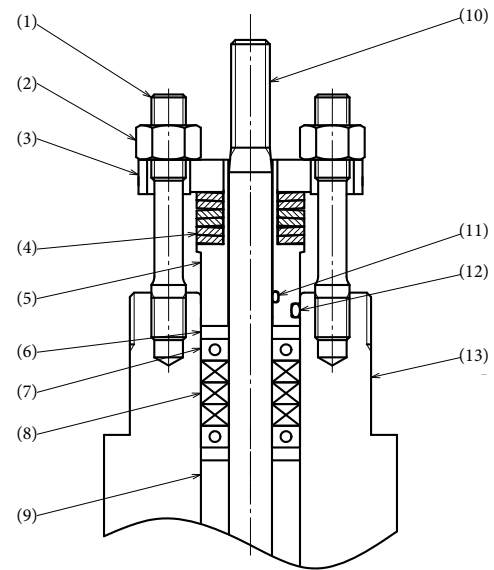

Fig. 11-1. Structure of Certified ISO 15848-1 low emission gland packing (for PTFE yarn)

No.	Name
(1)	Gland stud
(2)	Gland nut
(3)	Packing flange
(4)	Belleville spring
(5)	Packing follower
(6)	Carbon ring (P6210)
(7)	Adapter packing (P6720)
(8)	Main packing (P6617CL)
(9)	Spacer
(10)	Stem
(11)	O-ring for inner side of packing follower (optional)
(12)	O-ring for outer side of the packing follower (optional)
(13)	Stuffing box

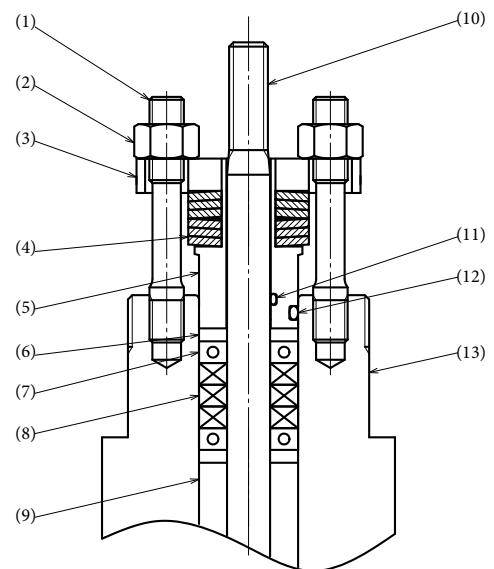

Fig. 11-2. Structure of Certified ISO 15848-1 low emission gland packing (for expanded graphite)

## 11-2. Structure

The main packing (No. P4519) is PTFE yarn with a carbon fiber core. It features low friction and can be used for various types of fluids. The main packing (No. P6617CL) is an expanded graphite packing. The part of it that slides is aligned with an expanded graphite sheet that was specially modified and lubricated. The adapter packing (No. P6720) is made by braiding expanded graphite yarn reinforced with PTFE fiber, and features low friction.

These gland packings are tightened by the live-loaded packing system, which is composed of Belleville springs and other parts. With other systems, in the course of valve operation, seal performance deteriorates due to loosening of the gland packing. The force of the Belleville springs reduces the release of tension to maintain the seal. The load on the Belleville springs can be observed from the position of the packing flange and packing follower.

## 11-3. Starting Operation

Before operating the valve, tighten (or retighten) the gland. For instructions, refer to 11-4-2, “(3) Tightening”.

If leakage from the gland continues even after proper tightening, obtain and prepare parts as indicated in “11-4-1. Preparation for assembly”, and follow the procedure given in “11-4-2. Assembly”.

## 11-4. Assembling the parts of the gland

### 11-4-1. Preparation for assembly

#### (1) Checking the surface condition of the parts

Any flaw or the like on the surface of the parts may cause leakage from that area, resulting in a total amount of leakage from the gland that exceeds the specified value. Therefore, check the surface of the following parts.

Table 11-1. Parts to be checked for surface condition

Part	Checkpoints	Possible problems
Stem	<ul style="list-style-type: none"> <li>• No flaws or defects, including scratches and dents</li> <li>• No rust or corrosion</li> <li>• The entire surface is even.</li> <li>• No burrs</li> <li>• Clean surface, with no adhering coating material, powder, or dirt.</li> <li>• If necessary, take necessary measures such as cleaning with alcohol.</li> </ul>	If the problems stated on the left remain, fluid leaks from flawed areas may cause the total amount of leakage from the gland to exceed the specified value.
Stuffing box		
Both ends of the spacer		
Packing follower		
Packing contact surface		
O-ring groove		
Packing flange Gland nut contact surface		The total amount of leakage from the gland may exceed the specified value because of insufficient tightening.
Packing flange (entire surface) Gland stud Gland nut	<ul style="list-style-type: none"> <li>• No flaws, rust, or defects</li> </ul>	The problems on the left, if they remain, can cause control valve damage, leading to injuries.

### (2) New parts

When assembling or reassembling, for the parts indicated in the table below, be sure to use new parts.

Table 11-2. Parts requiring treatment

Part name	Checkpoints	Possible problems
Gland packing (main packing and adapter packing) Carbon ring	<ul style="list-style-type: none"><li>• No flaws.</li><li>• No coating materials or dirt stuck to the surface.</li></ul>	Fluid leaks from flawed areas can cause the total amount of leakage from the gland to exceed the specified value.
Belleville spring		The total amount of leakage from the gland may exceed the specified value in a short period of time because of insufficient tightening.

### (3) Lubricating grease and anti-seizing agent

Have an appropriate amount of the following lubricating grease and anti-seizing agent (or equivalent) on hand.

Table 11-3. Lubricating grease and anti-seizing agent

Product name	Applied area	Gland for PTFE yarn	Gland for expanded graphite
Krytox GPL207 fluoropolymer grease made by DuPont Co.	Entire surface of the gland packing (main packing and adapter packing)	Needed	-
Plastilube No. 3 non-dripping grease, made by Sulflo Inc.	Entire surface of the O-rings	Needed	Needed
Never-Seez anti-seizing agent, made by Bostik Inc.	Threads of the gland studs	Needed	Needed
	Bottom of the gland nuts	Needed	Needed



## 11-4-2. Assembly

### (1) Applying lubricating grease

#### Step 1

For Certified ISO 15848-1 low emission gland packing for PTFE yarn, apply a thin film of grease Krytox GPL207 indicated in Table 11-3 to the surface of all gland packings (main packing and adapter packing). For Certified ISO 15848-1 low emission gland packing for expanded graphite, greasing is not necessary.

#### Step 2

For Certified ISO 15848-1 low emission gland packing with two O-rings, which are placed inner and outer sides of the packing follower, apply grease Plastilube No.3 made by Sulflo Inc. indicated in Table 11-3 to both rings.

### (2) Assembling

(1/3)

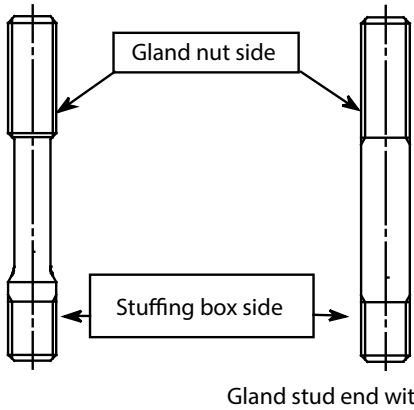
Step	Procedure
1	<p>Check the correct direction of the gland studs in Fig. 11-3. Apply Never-Seez anti-seizing agent made by Bostik Inc. (indicated in Table 11-3) to the threads on the stuffing box end of the studs, and screw them into the stuffing box.</p>  <p style="text-align: center;">Gland stud end with fewer threads Fig. 11-3. Direction of the gland stud</p>
2	First, insert the spacer, paying extra attention not to damage the surface of the stem.
3	Gently insert a carbon ring all the way to the bottom with a pipe, etc., taking care not to damage the ring.

Step	Procedure
4	<p><b>[Certified ISO 15848-1 low emission gland packing for PTFE yarn]</b></p> <p>Insert one adapter packing ring, without opening the gap, all the way to the bottom with a pipe, etc., and push it lightly.</p> <p>Open the gap of the main packing rings as illustrated in Fig. 11-4 and insert one of them all the way to the bottom with a pipe, etc., and push it lightly. Insert the remaining two main packing rings with the gap position shifted by 180°.</p> <p>Insert one adapter packing ring, without opening the gap, all the way to the bottom with a pipe, etc., and push it lightly.</p> <div data-bbox="746 591 1203 824" style="text-align: center;"> </div> <p style="text-align: center;">Fig. 11-4. How to open the main packing rings</p> <p><b>[Certified ISO 15848-1 low emission gland packing for expanded graphite]</b></p> <p>Insert one adapter packing ring, without opening the gap, all the way to the bottom with a pipe, etc., and push it lightly.</p> <p>Insert one of the main packing rings, without opening the gap, with the marking facing upward, all the way to the bottom with a pipe, etc., and push it lightly. Insert the remaining two main packing rings in the same manner.</p> <p>Insert one adapter packing ring, without opening the gap, all the way to the bottom with a pipe, etc., and push it lightly.</p>
5	Gently insert a carbon ring all the way to the bottom with a pipe, etc., taking care not to damage the ring.
6	Check the correct mounting orientation of the packing follower in Fig. 11-1. or Fig. 11-2. Insert it, paying extra attention not to damage the surface of the stem.

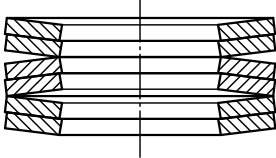
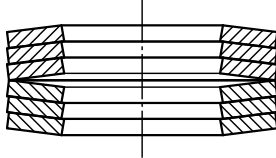
Step	Procedure
7	<p>Stack the Belleville spring washers as shown in Fig. 11-5, and insert them into the packing follower.</p> <div style="display: flex; justify-content: space-around; align-items: center;"> <div style="text-align: center;">  <p>2 same-direction washers × 3 [For PTFE yarn]</p> </div> <div style="text-align: center;">  <p>3 same-direction washers × 2 [For expanded graphite]</p> </div> </div> <p style="text-align: center;">Fig. 11-5.</p>
8	Place the packing flange onto the packing follower.
9	Apply anti-seizing agent Never-Seez made by Bostik Inc. (Table 11-3) to the threads on the gland nut end of the gland studs, and screw the nuts on by hand.

**(3) Tightening**

Step	Procedure																																								
1	<p>Tighten the left and right gland nuts alternately, making approximately a half turn each, until the torque indicated in Table 11-4 or Table 11-5 is reached. Note that if the tightening torque is insufficient, the amount of leakage may exceed the specified value. On the other hand, tightening the gland nuts with excessive torque increases the friction on the stem and causes the gland packing to wear out faster, which may lead to an amount of leakage exceeding the specified value in a short period of time.</p> <p>Table 11-4. Gland nut tightening torque (for PTFE yarn)</p> <table border="1" style="width: 100%; border-collapse: collapse;"> <thead> <tr> <th>Model</th> <th>Actuator model</th> <th>Stem size</th> <th>Tightening torque</th> </tr> </thead> <tbody> <tr> <td rowspan="5" style="text-align: center;">HCB,HCN</td> <td>HA2</td> <td>φ 10 mm</td> <td>12 N·m</td> </tr> <tr> <td>HA3</td> <td>φ 13 mm</td> <td>20 N·m</td> </tr> <tr> <td>HA3</td> <td>φ 16 mm</td> <td>33 N·m</td> </tr> <tr> <td>HA4</td> <td>φ 20 mm</td> <td>44 N·m</td> </tr> <tr> <td>PSA6</td> <td>φ 30 mm</td> <td>54 N·m</td> </tr> </tbody> </table> <p>Table 11-5. Gland nut tightening torque (for expanded graphite)</p> <table border="1" style="width: 100%; border-collapse: collapse;"> <thead> <tr> <th>Model</th> <th>Actuator model</th> <th>Stem size</th> <th>Tightening torque</th> </tr> </thead> <tbody> <tr> <td rowspan="5" style="text-align: center;">HCB,HCN</td> <td>HA2</td> <td>φ 10 mm</td> <td>12 → 0 (loosening) → 8 N·m</td> </tr> <tr> <td>HA3</td> <td>φ 13 mm</td> <td>20 → 0 (loosening) → 13N·m</td> </tr> <tr> <td>HA3</td> <td>φ 16 mm</td> <td>33 → 0 (loosening) → 22N·m</td> </tr> <tr> <td>HA4</td> <td>φ 20 mm</td> <td>44 → 0 (loosening) → 30N·m</td> </tr> <tr> <td>PSA6</td> <td>φ 30 mm</td> <td>54 → 0 (loosening) → 36N·m</td> </tr> </tbody> </table>	Model	Actuator model	Stem size	Tightening torque	HCB,HCN	HA2	φ 10 mm	12 N·m	HA3	φ 13 mm	20 N·m	HA3	φ 16 mm	33 N·m	HA4	φ 20 mm	44 N·m	PSA6	φ 30 mm	54 N·m	Model	Actuator model	Stem size	Tightening torque	HCB,HCN	HA2	φ 10 mm	12 → 0 (loosening) → 8 N·m	HA3	φ 13 mm	20 → 0 (loosening) → 13N·m	HA3	φ 16 mm	33 → 0 (loosening) → 22N·m	HA4	φ 20 mm	44 → 0 (loosening) → 30N·m	PSA6	φ 30 mm	54 → 0 (loosening) → 36N·m
Model	Actuator model	Stem size	Tightening torque																																						
HCB,HCN	HA2	φ 10 mm	12 N·m																																						
	HA3	φ 13 mm	20 N·m																																						
	HA3	φ 16 mm	33 N·m																																						
	HA4	φ 20 mm	44 N·m																																						
	PSA6	φ 30 mm	54 N·m																																						
Model	Actuator model	Stem size	Tightening torque																																						
HCB,HCN	HA2	φ 10 mm	12 → 0 (loosening) → 8 N·m																																						
	HA3	φ 13 mm	20 → 0 (loosening) → 13N·m																																						
	HA3	φ 16 mm	33 → 0 (loosening) → 22N·m																																						
	HA4	φ 20 mm	44 → 0 (loosening) → 30N·m																																						
	PSA6	φ 30 mm	54 → 0 (loosening) → 36N·m																																						

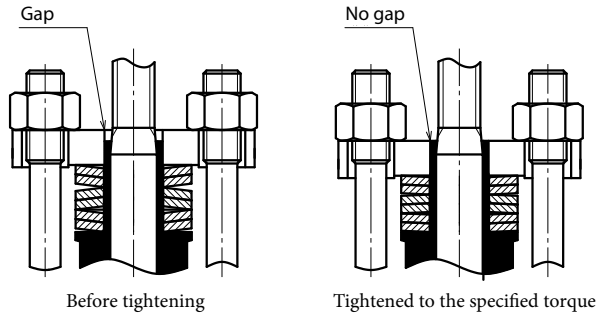
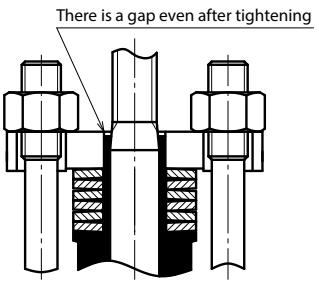
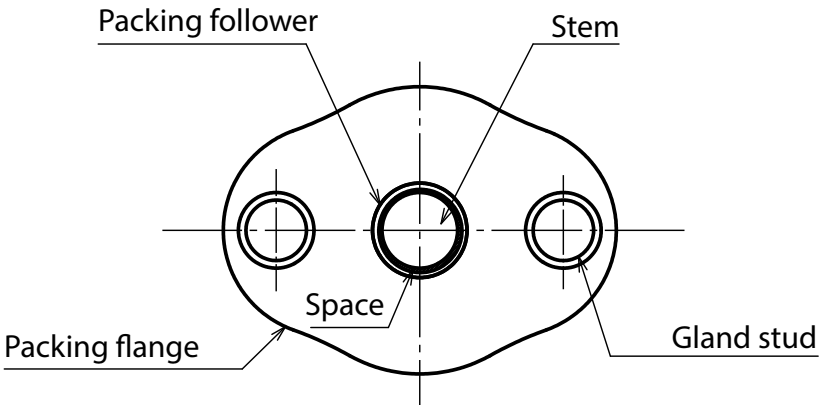
Step	Procedure
2	<p data-bbox="507 280 1412 405">By tightening the gland nuts to the torque indicated in Table 11-4 or Table 11-5, the top of the packing flange and packing follower will be at almost the same level, as illustrated in Fig. 11-6 below (the level may not be exactly the same due to the tolerance of the Belleville springs and friction on the gland studs or gland nuts).</p> <p data-bbox="507 421 1401 577">If the Belleville springs are mounted in the wrong direction, or if the gland nuts are tightened to a torque that does not comply with the torque specified in Table 11-4 and Table 11-5, the level of the top of the packing flange and packing follower will not be the same (see Fig. 11-7). Check if the direction of washers of the Belleville springs and the tightening torque are correct.</p> <div data-bbox="651 593 1252 907"><p data-bbox="651 922 1284 952">Fig. 11-6. Load on Belleville springs (correctly assembled)</p></div> <div data-bbox="805 974 1125 1254"><p data-bbox="638 1265 1295 1294">Fig. 11-7. Load on Belleville springs (incorrectly assembled)</p></div>
3	<p data-bbox="507 1314 1369 1375">View the assembly from above to check that the space between the stem and the packing follower is even (see Fig. 11-8).</p> <div data-bbox="550 1411 1372 1814"><p data-bbox="861 1832 1069 1861">Fig. 11-8. Top view</p></div>

## 11-5. Parts List

Table 11-6. Parts list for PTFE yarn

Part name	Actuator model	Material	Part No.	Qty.
Main packing	HA2	P4519	80255384- 111	3
Adapter packing		P6720	82573475- 101	2
Carbon ring		P6210C2FS	82573484- 001	2
Belleville spring		SUS304	82573462- 101	6
O-ring (small)		Viton	82592220- 897	1
O-ring (large)		Viton	82592221- 897	1
Gland stud		A193 GrB8CL2	82559311- 012	2
Gland nut		SUS304	82592448- 163	2
Packing flange		SCS13	82573456- 101	1
Packing follower		SUS304	82573463- 101	1
Packing follower for O-ring use		SUS304	82573464- 101	1
Spacer		SUS304	82573476- 110	1
Main packing		HA3 (except 6B)	P4519	80255385- 111
Adapter packing	P6720		82573475- 102	2
Carbon ring	P6210C2FS		82573484- 002	2
Belleville spring	SUS304		82573462- 102	6
O-ring (small)	Viton		82592221- 497	1
O-ring (large)	Viton		82592222- 297	1
Gland stud	A193 GrB8CL2		82571706- 012	2
Gland nut	SUS304		82592448- 173	2
Packing flange	SCS13		82573457- 101	1
Packing follower	SUS304		82573465- 101	1
Packing follower for O-ring use	SUS304		82573466- 101	1
Spacer	SUS304		82573476- 111	1
Stem connector	S25C/S20C		82571732- 101	1
Main packing	HA3 (6B)	P4519	80255386- 111	3
Adapter packing		P6720	82573475- 103	2
Carbon ring		P6210C2FS	82573484- 003	2
Belleville spring		SUS304	82573462- 103	6
O-ring (small)		Viton	82592221- 797	1
O-ring (large)		Viton	82592222- 897	1
Gland stud		A193 GrB8CL2	82559312- 012	2
Gland nut		SUS304	82592448- 013	2
Packing flange		SCS13	82573458- 101	1
Packing follower		SUS304	82573467- 101	1
Packing follower for O-ring use		SUS304	82573468- 101	1
Spacer		SUS304	82573476- 112	1

Part name	Actuator model	Material	Part No.	Qty.
Main packing	HA4	P4519	80255387- 111	3
Adapter packing		P6720	82573475- 104	2
Carbon ring		P6210C2FS	82573484- 004	2
Belleville spring		SUS304	82573462- 104	6
O-ring (small)		Viton	82592221- 997	1
O-ring (large)		Viton	82592223- 397	1
Gland stud		A193 GrB8CL2	82571707- 012	2
Gland nut		SUS304	82592448- 023	2
Packing flange		SCS13	82573459- 101	1
Packing follower		SUS304	82573469- 101	1
Packing follower for O-ring use		SUS304	82573470- 101	1
Spacer		SUS304	82573476- 113	1
Main packing		PSA6R DAP560	P4519	82571048- 109
Adapter packing	P6720		82573475- 204	2
Carbon ring	P6210C2FS		82573484- 010	2
Belleville spring	SUS304		82573462- 105	6
O-ring (small)	Viton		82592223- 397	1
O-ring (large)	Viton		82592224- 197	1
Gland stud	A193 GrB8CL2		82592006- 769	2
Gland nut	SUS304		82592448- 033	2
Packing flange	SCS13		82573460- 101	1
Packing follower	SUS304		82573471- 101	1
Packing follower for O-ring use	SUS304		82573472- 101	1
Spacer	SUS304		82553331- 781	1

Table 11-7. Parts list for expanded graphite

Part name	Actuator model	Material	Part No.	Qty.
Main packing	HA2	P6617CL	82573489- 001	3
Adapter packing		P6720	82573475- 101	2
Carbon ring		P6210	82573488- 001	2
Belleville spring		SUS304	82571710- 101	6
O-ring (small)		Viton	82592220- 897	1
O-ring (large)		Viton	82592221- 897	1
Gland stud		A193 GrB8CL2	82559311- 012	2
Gland nut		SUS304	82592448- 163	2
Packing flange		SCS13	82573456- 101	1
Packing follower		SUS304	82573463- 201	1
Packing follower for O-ring use		SUS304	82573464- 201	1
Spacer		SUS304	82573476- 114	1
Main packing		HA3 (except 6B)	P6617CL	82573489- 002
Adapter packing	P6720		82573475- 102	2
Carbon ring	P6210		82573488- 002	2
Belleville spring	SUS304		82573462- 107	6
O-ring (small)	Viton		82592221-497	1
O-ring (large)	Viton		82592222-297	1
Gland stud	A193 GrB8CL2		82571706- 012	2
Gland nut	SUS304		82592448- 173	2
Packing flange	SCS13		82573457- 101	1
Packing follower	SUS304		82573465- 201	1
Packing follower for O-ring use	SUS304		82573466- 201	1
Spacer	SUS304		82573476- 115	1
Stem connector	S25C/S20C		82571732- 101	1
Main packing	HA3 (6B)	P6617CL	82573489- 003	3
Adapter packing		P6720	82573475- 103	2
Carbon ring		P6210	82573488- 003	2
Belleville spring		SUS304	82559308- 102	6
O-ring (small)		Viton	82592221- 797	1
O-ring (large)		Viton	82592222- 897	1
Gland stud		A193 GrB8CL2	82559311- 012	2
Gland nut		SUS304	82592448- 163	2
Packing flange		SCS13	82573458- 101	1
Packing follower		SUS304	82573467- 201	1
Packing follower for O-ring use		SUS304	82573468- 201	1
Spacer		SUS304	82573476- 116	1

Part name	Actuator model	Material	Part No.	Qty.
Main packing	HA4	P6617CL	82573489- 004	3
Adapter packing		P6720	82573475- 104	2
Carbon ring		P6210	82573488- 004	2
Belleville spring		SUS304	82573462- 108	6
O-ring (small)		Viton	82592221- 997	1
O-ring (large)		Viton	82592223- 397	1
Gland stud		A193 GrB8CL2	82571707- 012	2
Gland nut		SUS304	82592448- 023	2
Packing flange		SCS13	82573459- 101	1
Packing follower		SUS304	82573469- 201	1
Packing follower for O-ring use		SUS304	82573470- 201	1
Spacer		SUS304	82573476- 117	1
Main packing		PSA6R	P6617CL	82573489- 009
Adapter packing	P6720		82573475- 204	2
Carbon ring	P6210		82573488- 010	2
Belleville spring	SUS304		82573462- 109	6
O-ring (small)	Viton		82592223- 397	1
O-ring (large)	Viton		82592224- 197	1
Gland stud	A193 GrB8CL2		82592006- 769	2
Gland nut	SUS304		82592448- 033	2
Packing flange	SCS13		82573460- 101	1
Packing follower	SUS304		82573471- 201	1
Packing follower for O-ring use	SUS304		82573472- 201	1
Spacer	SUS304		82553331- 779	1



## 11-6. Application to existing control valves

If Certified ISO 15848-1 low emission gland packing is used for an existing control valve, please note the following:

- If there are scratches on the inner surface of the stuffing box or the surface of the stem of the current valve, the specified seal performance of Certified ISO 15848-1 low emission gland packing may not be achieved. If scratches are found, replace the affected parts with new ones.
- Check if Certified ISO 15848-1 low emission gland packing can be used for the current valve and actuator by referring to the specification sheet for Certified ISO 15848-1 low emission gland packing (SS2-SSL100-0100) or by contacting us. Because the resistance to sliding of Certified ISO 15848-1 low emission gland packing is greater than general gland packing systems, it may not be possible to use Certified ISO 15848-1 low emission gland packing with the current actuator. In addition, if it is used with the actuator, the shutoff differential pressure will decrease. If supply air pressure to the actuator is increased in order to meet the required shutoff differential pressure, check that the specifications for the pressure gauge of the positioner and pressure reducing valve are satisfied and that there is no effect on the pressure at the source.
- Check if the operating temperature range of the gland packing (main packing and adapter packing) of Certified ISO 15848-1 low emission gland packing meets the temperature requirements of the current control valve. Attention is needed for expanded graphite Certified ISO 15848-1 low emission gland packing in particular, because the operating temperature high limit of the main packing used for this packing system is lower than that of general expanded graphite packings.

## 11-7. Disposal

If this product is no longer needed, dispose of it appropriately as industrial waste, in accordance with local regulations. Do not reuse all or any part of it.



## Chapter 12. Troubleshooting

This chapter covers the symptoms, causes and remedies of most probable types of troubles. Parts may be required to be replaced depending on the type of trouble.

For further troubles, please order your Azbil Corporation agent for repair.

Table 1-1 Troubleshooting

Symptom	Cause and Remedy
Unstable valve operation <ul style="list-style-type: none"> <li>Valve position hunting occurs when almost fully closed.</li> <li>Air supply pressure is unstable.</li> <li>Signal pressure is unstable.</li> <li>Valve position hunting occurs even when signal pressure is stable.</li> </ul>	<ul style="list-style-type: none"> <li>Cv value is too large. Reduce Cv value.</li> <li>For a single scat Valve, the valve is Installed in the reverse flow direction.</li> <li>Large air consuming equipment is hooked up to the same air supply line. Check that the air supply capacity piping capacity and restriction capacity are appropriate.</li> <li>Supply air pressure regulator is inadequate or not operating properly.</li> <li>Controller is not properly tuned. Property tune the controller (properly set the proportional band and other parameters).</li> <li>Check that the controller output does not change abnormally.</li> <li>Hunting of output of positioner itself. Check and repair or replace the positioner.</li> <li>Being affected by pressure change of process fluid as power of the actuator is insufficient. Replace the actuator with a larger one.</li> </ul>
Vibration of valve <ul style="list-style-type: none"> <li>Valve vibrates (generate noise) at any position of valve plug.</li> <li>Valve vibrates (generate noise) only when valve plug is set at a certain position.</li> </ul>	<ul style="list-style-type: none"> <li>Piping is vibrating. Securely fix the piping.</li> <li>Check for other sources of vibration. Worn valve plug or guides. Check the parts and replace them as required.</li> <li>Check for change in process fluid flow conditions (change in restriction orifice, Cv value, etc.)</li> <li>Check for change in plug configuration (change in flow control characteristics.)</li> </ul>
Sluggish valve operation or inoperative Valve	<ul style="list-style-type: none"> <li>Air leak from piping</li> <li>Air leak from actuator</li> <li>Foreign matter entrapped in guide section of valve plug.</li> <li>Aged and hardened gland packing, causing increased hysteresis</li> <li>Malfunctioning positioner (Check the positioner by operating it directly on an air supply known to be operating normally.)</li> </ul>
Fluid leak from gland section	<ul style="list-style-type: none"> <li>Check for loose packing flange.</li> <li>Check for insufficient grease.</li> <li>Check for damaged valve shaft.</li> </ul>
Liquid leak from gasket section	<ul style="list-style-type: none"> <li>Check for Ioose nuts of bonnet.</li> <li>Check for defective gasket (deformed or damaged).</li> </ul>

Symptom	Cause and Remedy
<p>Even when valve plug is in closed position, large flow leaks to downstream side.</p>	<ul style="list-style-type: none"> <li>• Air leak at actuator section.</li> <li>• For trial, apply the air supply pressure or atmospheric pressure to the actuator. (Check the air supply source and positioner.)</li> <li>• Check whether the valve plug is actually the closed position or not. (Check the valve plug lift)</li> <li>• Check the plug seat ring for corrosion and erosion.</li> <li>• Check the guide sections for binding.</li> </ul>

## Chapter 13. Recommended Spare Parts

It is most recommendable to replace the following parts when servicing the control valve.

- **Valve Body**

Be sure to replace the following parts with fresh ones whenever the valve body is disassembled:

- Gland packing
- Gaskets

- **Actuator**

Replace the following Parts at every 5 years or thereabout.

- Diaphragm
  - Bushing
  - Seal washer
  - Dust seal
  - Rod packing
- } Be sure to replace these parts whenever the actuator is disassembly.

Of the bellows sealed type of control valves, the bellows seal assembly\* must be replaced periodically. The period of replacement depends on temperature, pressure and other conditions of use. A typical service longevity of the bellows assembly is 10,000 vertical stroke cycles.

\* The bellows seal assembly has the seal bellows and valve stem (including the bellows seat) assembled together.

Please mention the parts name and the product number indicated on the name plate when ordering those spare parts.





# Terms and Conditions

We would like to express our appreciation for your purchase and use of Azbil Corporation's products. You are required to acknowledge and agree upon the following terms and conditions for your purchase of Azbil Corporation's products (system products, field instruments, control valves, and control products), unless otherwise stated in any separate document, including, without limitation, estimation sheets, written agreements, catalogs, specifications and instruction manuals.

## 1. Warranty period and warranty scope

### 1.1 Warranty period

Azbil Corporation's products shall be warranted for one (1) year from the date of your purchase of the said products or the delivery of the said products to a place designated by you.

### 1.2 Warranty scope

In the event that Azbil Corporation's product has any failure attributable to azbil during the aforementioned warranty period, Azbil Corporation shall, without charge, deliver a replacement for the said product to the place where you purchased, or repair the said product and deliver it to the aforementioned place. Notwithstanding the foregoing, any failure falling under one of the following shall not be covered under this warranty:

- (1) Failure caused by your improper use of azbil product (noncompliance with conditions, environment of use, precautions, etc. set forth in catalogs, specifications, instruction manuals, etc.);
- (2) Failure caused for other reasons than Azbil Corporation's product;
- (3) Failure caused by any modification or repair made by any person other than Azbil Corporation or Azbil Corporation's subcontractors;
- (4) Failure caused by your use of Azbil Corporation's product in a manner not conforming to the intended usage of that product;
- (5) Failure that the state-of-the-art at the time of Azbil Corporation's shipment did not allow Azbil Corporation to predict; or
- (6) Failure that arose from any reason not attributable to Azbil Corporation, including, without limitation, acts of God, disasters, and actions taken by a third party.

Please note that the term "warranty" as used herein refers to equipment-only-warranty, and Azbil Corporation shall not be liable for any damages, including direct, indirect, special, incidental or consequential damages in connection with or arising out of Azbil Corporation's products.

## 2. Ascertainment of suitability

You are required to ascertain the suitability of Azbil Corporation's product in case of your use of the same with your machinery, equipment, etc. (hereinafter referred to as "Equipment") on your own responsibility, taking the following matters into consideration:

- (1) Regulations and standards or laws that your Equipment is to comply with.
- (2) Examples of application described in any documents provided by Azbil Corporation are for your reference purpose only, and you are required to check the functions and safety of your Equipment prior to your use.
- (3) Measures to be taken to secure the required level of the reliability and safety of your Equipment in your use

Although azbil is constantly making efforts to improve the quality and reliability of Azbil Corporation's products, there exists a possibility that parts and machinery may break down.

You are required to provide your Equipment with safety design such as fool-proof design, \*1 and fail-safe design\*2 (anti-flame propagation design, etc.), whereby preventing any occurrence of physical injuries, fires, significant damage, and so forth. Furthermore, fault avoidance, \*3 fault tolerance,\*4 or the like should be incorporated so that the said Equipment can satisfy the level of reliability and safety required for your use.

\*1. A design that is safe even if the user makes an error.

\*2. A design that is safe even if the device fails.

\*3. Avoidance of device failure by using highly reliable components, etc.

\*4. The use of redundancy.

## 3. Precautions and restrictions on application

Azbil Corporation's products other than those explicitly specified as applicable (e.g. azbil Limit Switch For Nuclear Energy) shall not be used in a nuclear energy controlled area (radiation controlled area).

Any Azbil Corporation's products shall not be used for/with medical equipment.

The products are for industrial use. Do not allow general consumers to install or use any Azbil Corporation's product.

However, azbil products can be incorporated into products used by general consumers. If you intend to use a product for that purpose, please contact one of our sales representatives.

In addition,

you are required to conduct a consultation with our sales representative and understand detail specifications, cautions for operation, and so forth by reference to catalogs, specifications, instruction manual, etc. in case that you intend to use azbil product for any purposes specified in (1) through (6) below.

Moreover, you are required to provide your Equipment with fool-proof design, fail-safe design, anti-flame propagation design, fault avoidance, fault tolerance, and other kinds of protection/safety circuit design on your own responsibility to ensure reliability and safety, whereby preventing problems caused by failure or nonconformity.

- (1) For use under such conditions or in such environments as not stated in technical documents, including catalogs, specification, and instruction manuals



- (2) For use of specific purposes, such as:
  - \* Nuclear energy/radiation related facilities  
[For use outside nuclear energy controlled areas] [For use of Azbil Corporation's Limit Switch For Nuclear Energy]
  - \* Machinery or equipment for space/sea bottom
  - \* Transportation equipment  
[Railway, aircraft, vessels, vehicle equipment, etc.]
  - \* Antidisaster/crime-prevention equipment
  - \* Burning appliances
  - \* Electrothermal equipment
  - \* Amusement facilities
  - \* Facilities/applications associated directly with billing
- (3) Supply systems such as electricity/gas/water supply systems, large-scale communication systems, and traffic/air traffic control systems requiring high reliability
- (4) Facilities that are to comply with regulations of governmental/public agencies or specific industries
- (5) Machinery or equipment that may affect human lives, human bodies or properties
- (6) Other machinery or equipment equivalent to those set forth in items (1) to (5) above which require high reliability and safety

#### 4. Precautions against long-term use

Use of Azbil Corporation's products, including switches, which contain electronic components, over a prolonged period may degrade insulation or increase contact-resistance and may result in heat generation or any other similar problem causing such product or switch to develop safety hazards such as smoking, ignition, and electrification. Although acceleration of the above situation varies depending on the conditions or environment of use of the products, you are required not to use any Azbil Corporation's products for a period exceeding ten (10) years unless otherwise stated in specifications or instruction manuals.

#### 5. Recommendation for renewal

Mechanical components, such as relays and switches, used for Azbil Corporation's products will reach the end of their life due to wear by repetitious open/close operations. In addition, electronic components such as electrolytic capacitors will reach the end of their life due to aged deterioration based on the conditions or environment in which such electronic components are used. Although acceleration of the above situation varies depending on the conditions or environment of use, the number of open/close operations of relays, etc. as prescribed in specifications or instruction manuals, or depending on the design margin of your machine or equipment, you are required to renew any Azbil Corporation's products every 5 to 10 years unless otherwise specified in specifications or instruction manuals. System products, field instruments (sensors such as pressure/flow/level sensors, regulating valves, etc.) will reach the end of their life due to aged deterioration of parts. For those parts that will reach the end of their life due to aged deterioration, recommended replacement cycles are prescribed. You are required to replace parts based on such recommended replacement cycles.

#### 6. Other precautions

Prior to your use of Azbil Corporation's products, you are required to understand and comply with specifications (e.g., conditions and environment of use), precautions, warnings/cautions/notices as set forth in the technical documents prepared for individual Azbil Corporation's products, such as catalogs, specifications, and instruction manuals to ensure the quality, reliability, and safety of those products.

#### 7. Changes to specifications

Please note that the descriptions contained in any documents provided by azbil are subject to change without notice for improvement or for any other reason. For inquires or information on specifications as you may need to check, please contact our branch offices or sales offices, or your local sales agents.

#### 8. Discontinuance of the supply of products/parts

Please note that the production of any Azbil Corporation's product may be discontinued without notice. For repairable products, we will, in principle, undertake repairs for five (5) years after the discontinuance of those products. In some cases, however, we cannot undertake such repairs for reasons, such as the absence of repair parts. For system products, field instruments, we may not be able to undertake parts replacement for similar reasons.

#### 9. Scope of services

Prices of Azbil Corporation's products do not include any charges for services such as engineer dispatch service. Accordingly, a separate fee will be charged in any of the following cases:

- (1) Installation, adjustment, guidance, and attendance at a test run
- (2) Maintenance, inspection, adjustment, and repair
- (3) Technical guidance and technical education
- (4) Special test or special inspection of a product under the conditions specified by you

Please note that we cannot provide any services as set forth above in a nuclear energy controlled area (radiation controlled area) or at a place where the level of exposure to radiation is equivalent to that in a nuclear energy controlled area.



---

**Document Number:** OM2-8113-0202  
**Document Name:** Control Valves  
Model HCB\_ \_ \_/HCU\_ \_ \_/HCN\_ \_ \_/HPC\_ \_ \_  
User's Manual

---

**Date:** 9th Edition: June 2012  
13th Edition: Apr. 2023  
**Issued/Edited by:** Azbil Corporation  
Advanced Automation Company  
**Address:** 1-12-2 Kawana, Fujisawa  
kanagawa 251-8522 Japan  
**URL:** <https://www.azbil.com/global/>

---

Azbil Corporation