

**NEW 10-III**  
**Electric Single-Seated Control Valve**  
**Model ACT**

**User's Manual**

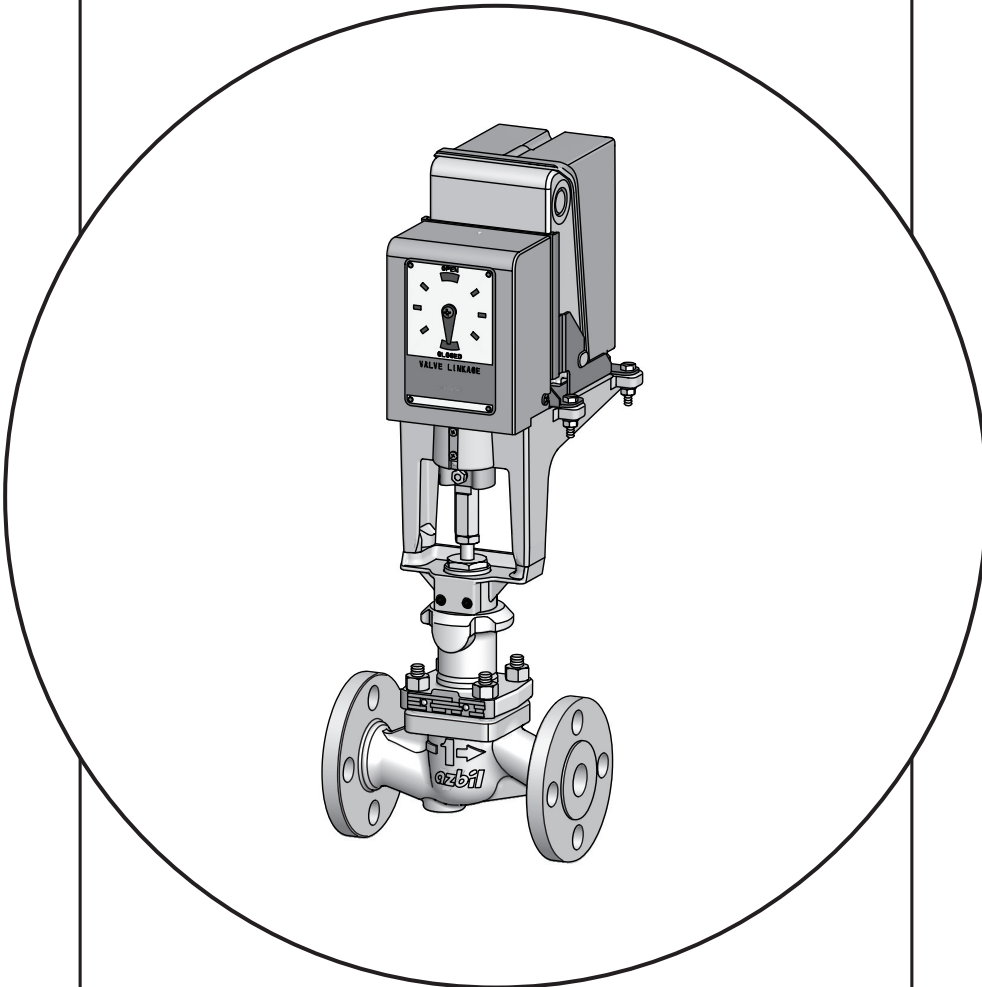

Azbil Corporation

## **NOTICE**

---

While the information in this manual is presented in good faith and believed to be accurate, Azbil Corporation disclaims any implied warranty of merchantability or fitness for a particular purpose and makes no express warranty except as may be stated in its written agreement with and for its customer.

In no event shall Azbil Corporation be liable to anyone for any indirect, special or consequential damages. This information and specifications in this document are subject to change without notice.

# Safety Precautions

## Symbols

Safety precautions are for ensuring safe and correct use of this product, and for preventing injury to the operator and others or damage to property. Be sure to observe these safety precautions.

Various symbols appear in this document.

Their meaning is explained below. Be sure to understand the meaning before reading the rest of the manual.



Warnings are indicated when mishandling the product might result in the death or serious injury of the user.



Cautions are indicated when mishandling the product might result in minor injury to the user or damage to property.

## Examples



Use caution when handling the product.



The indicated action is prohibited.



Be sure to follow the indicated instructions.

## Precautions for Safe Operation

### **WARNING**



Before starting to work, check that the pressure in the pipes has dropped to atmospheric pressure.  
Otherwise, if fluid spews out, injury may result.

### **CAUTION**



Do not stand on the device or use it as a step. There is a risk of falling.



Do not touch the device unnecessarily while it is operating. Depending on the operating conditions, the surface might be extremely hot or cold.



Since this product is heavy, when handling it, wear safety shoes and watch your step.



During work, wear protective goggles to prevent injury from flying objects.







During work, wear protective gloves to prevent injury due to burrs on bolt heads or edges.



While this device is operating, do not touch movable parts such as the stem connector. Your hand, etc., may be caught in the mechanism and injured.

# Handling Precautions

## Installation Precautions

 <b>WARNING</b>	
	If the rated pressure or standards for connection are ignored when this device is used, damage to the product or leakage may cause a serious accident.
	When connecting the valve to the piping, do not put your hand or foot under the valve or between flanges. You may lose your fingers or your foot may be injured.
	Before reinstalling the valve after maintenance or modification, wash out any residual fluid in the pipes or replace it with a safe fluid. Otherwise, the residual fluid may cause an injury.





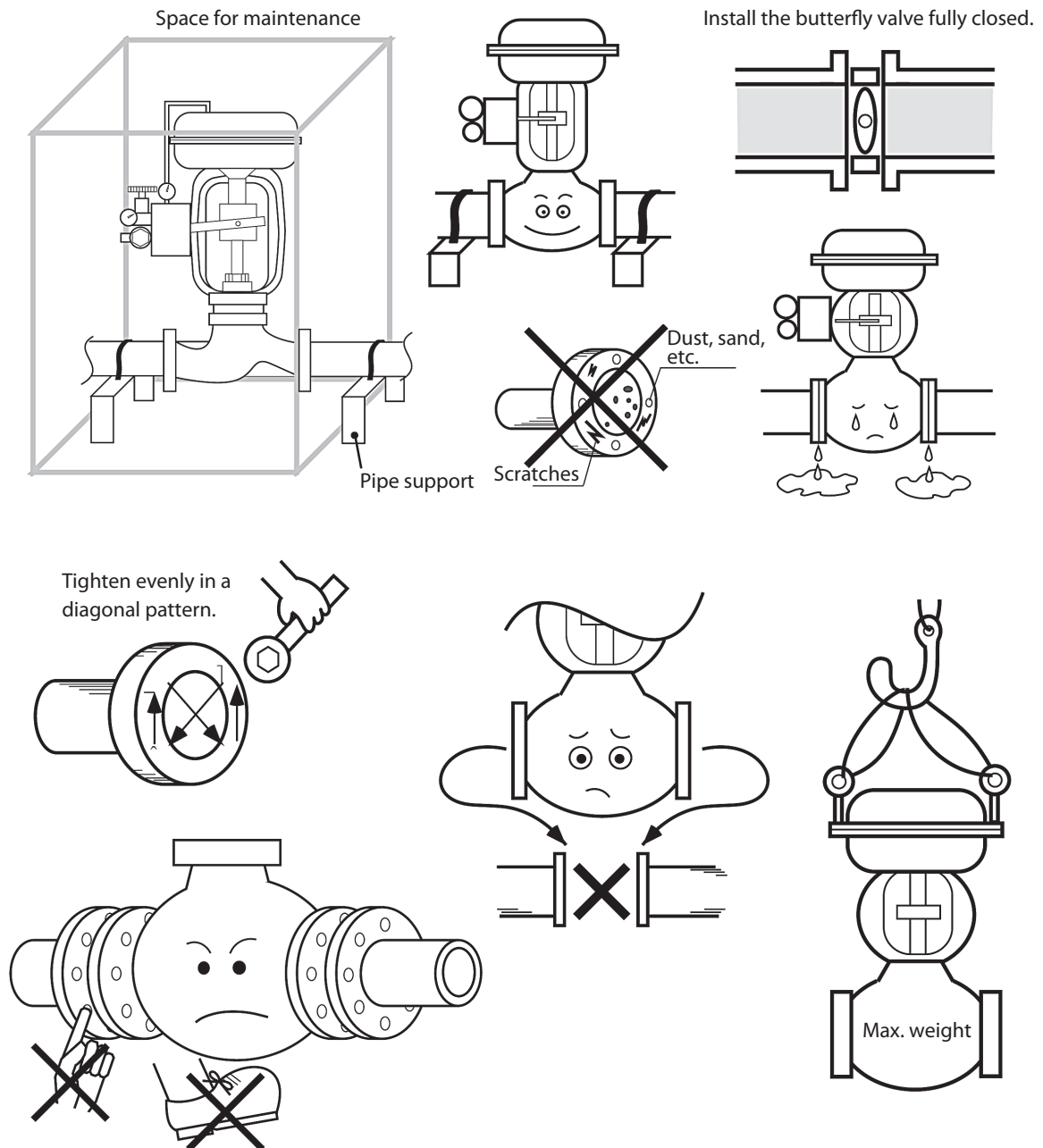

 <b>CAUTION</b>	
	Make sure that there is a straight pipe section at least 10 times the pipe diameter on the upstream side and 6 times the pipe diameter on the downstream side (D: nominal diameter). If the straight pipe sections are not long enough, insufficient valve capacity or unusual noise or vibration could result.
	Install the valve in the correct direction, leaving clearance around the valve as much as possible for easy maintenance (piping, wiring, adjustment, etc.).
	Provide appropriate support for the valve itself and for connected pipes to prevent an excessive load from the weight and operation of the valve. (Care is needed especially for large valves and valves for low-temperature fluid.)
	If the valve is installed along a passageway used by outsiders, install a fence or cover as a protective measure.
	Do not install the valve where it may be submerged by rainwater, covered with snow, or subject to freezing. Otherwise the valve may be damaged.
	If the valve is exposed to radiant heat, provide a shielding plate or the like. Failure to do so may result in damage to the actuator or auxiliary equipment.
	If the valve is exposed to salt or a corrosive atmosphere, take measures against corrosion. Otherwise the valve might be damaged.
	Check that there is no damage to the valve (including the actuator and auxiliary equipment).
	Check that there is no damage to the flanges or welded piping. Otherwise fluid leakage could result.
	If pipe flanges connected to the valve are being welded, the valve surface may also heat up. Do not touch the valve unnecessarily.
	Chamfer the edges of the pipe flanges. Sharp edges can cause an injury.
	Check that the pipes on both sides of the valve are firmly supported. Insufficient support may cause leakage from pipe connections.
	After installation, check that the pipes are still properly aligned. Misalignment may cause fluid leakage from pipe connections.
	Install the butterfly valve with the valve (blade or disk) fully closed. Otherwise the valve might be damaged.
	If the eyebolts (eyenuts) attached to the actuator are used to lift the valve, make sure that the weight does not exceed the limit specified in the user's manual. An excessive load may damage the actuator or cause air leakage.
	Use bolts and nuts that conform to the standards for the pipe flange. Otherwise fluid leakage could result.
	Use new flange gaskets that are appropriate for the properties of the fluid, the operating temperature, and the pressure. Damaged gaskets may cause fluid leakage.
	Open the valve fully before flushing the inside of the piping, and do not change the valve travel while the pipes are being flushed. Otherwise, the valve may be damaged by welding spatter or other foreign matter.

## ! Handling Precautions:

- Avoid installing the valve where it will be subject to vibration or other external forces that may affect its performance.
- Protective covers are attached to the flanges to protect the gasket-contacting surfaces and to prevent foreign matter from entering the valve. When installing the valve, remove the covers.
- Check that there is no damage to the valve (including the actuator and auxiliary equipment).
- To prevent seat damage and impaired closing performance, remove foreign matter such as dust, sand, and welding spatter from the inside of the piping, and clean the inside of the valve.
- Check that the distance between the pipe flanges is equal to the total of the face-to-face length of the valve and the thickness of the gaskets.
- Tighten the bolts and nuts for the flanges evenly in a diagonal pattern.



## Precautions for Air Supply Piping and Electrical Work

 <b>CAUTION</b>	
	For air supply, use pipes with an appropriate internal diameter so that pressure will not drop while the valve is operating. Failure to do so may result in poor valve performance.
	Wiring should be carried out only by qualified technicians and should comply with local electrotechnical standards.
	Cabling should be carried out in accordance with facility conditions. Use an adapter (and packing) whose size is appropriate for the outer diameter of the cable.
	If sealing tape is applied to air supply pipe threads, leave the two threads nearest the tip bare. Clogging caused by pieces of tape may result in poor valve performance.
	If liquid packing (thread lock sealant) is used for air supply piping work, do not allow it to enter inside the pipes. If it does, poor valve performance may result.
	Avoid doing wiring work on a rainy day or in high humidity. Moisture inside connectors or the terminal box may cause a short-circuit or rust.

### Handling Precautions:

- A packing (gasket) is attached to the cap of auxiliary equipment such as positioners. Do not lose it during wiring work.
- If it is necessary to bend the air supply pipes, make gentle bends (using a dedicated tool like a tube bender), and use a band to hold parallel pipes together.

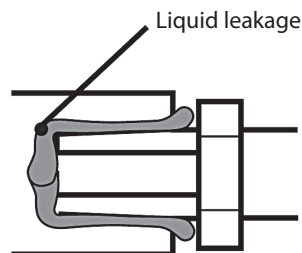
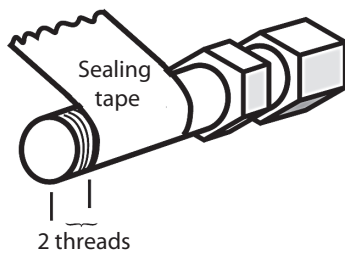
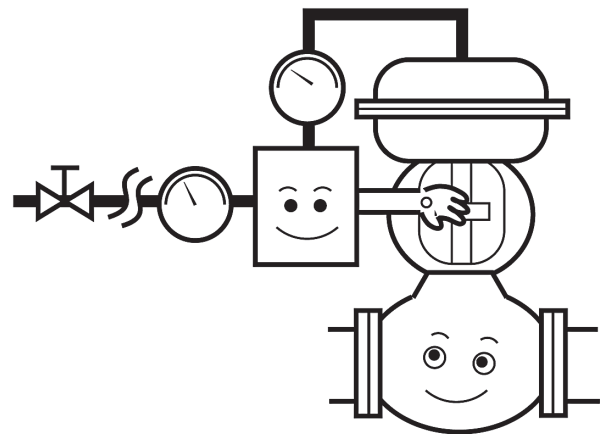
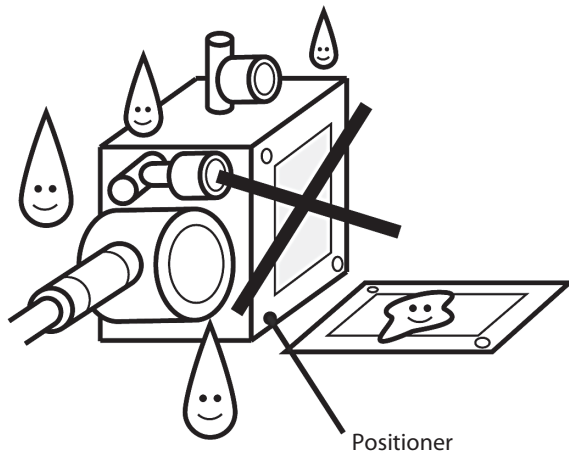

## Precautions for Assembly and Disassembly

### ⚠ WARNING

- ❗ Before starting work, clean the inside of the valve, replace any residual gas, etc. Otherwise, residual fluid may cause an injury.
- ❗ Because damaged or corroded bolts and nuts may damage the valve and cause injury, replace them with new ones.

### ⚠ CAUTION

- ❗ Observe the tightening torques indicated in the user's manual when tightening bolts and nuts.
- ❗ For an actuator that incorporates springs, follow the disassembly procedure when removing bolts, nuts, etc. Otherwise, the springs may jump out, causing injury.
- ❗ When removing the valve from the piping, if the eyebolts (eyenuts) attached to the actuator are used to hoist the valve, make sure that the weight does not exceed the limit specified in the user's manual. Otherwise there is a danger of the valve falling.
- ❗ Before removing or attaching the trim (internal valve), check whether a dedicated tool is necessary. If it is needed, be sure to use it. Otherwise, parts may be damaged.
- ❗ Assemble the valve using the parts, bolts, nuts, etc., in the order stated in the assembly procedure. Otherwise, malfunction may result.
- ❗ When reassembling the valve, use new packing and gaskets. The reuse of old parts may cause fluid leakage.

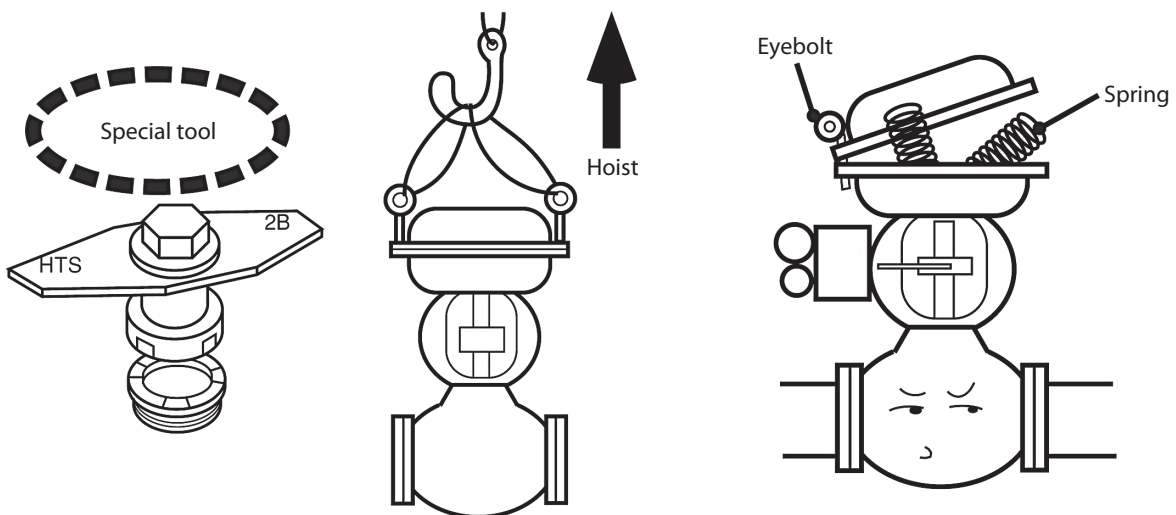



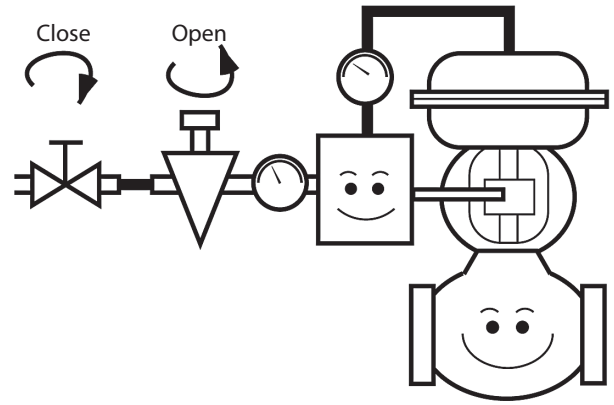
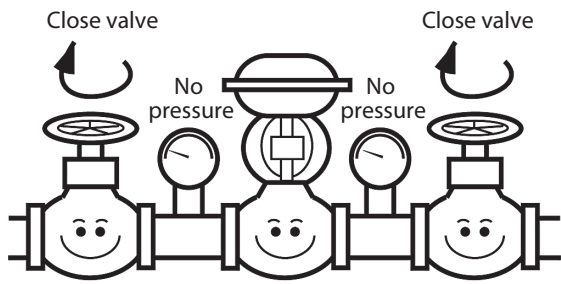

Follow the assembly procedure

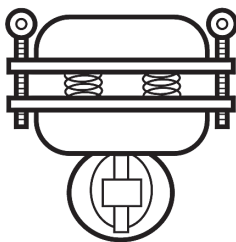

Replace the packing and gasket

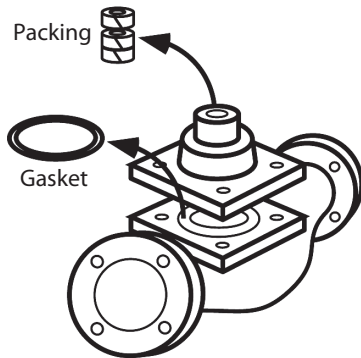



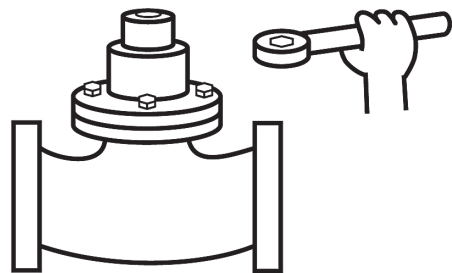

Tighten bolts to specified torque



## Precautions for Maintenance

 <b>WARNING</b>	
	If fluid leakage from the valve is found, stay away from the valve until safety can be confirmed. Depending on the properties of the fluid, a serious accident or injury may result.

 <b>CAUTION</b>	
	Check the gland daily, and tighten the packing if leakage is found.
	Check valve operation daily, including a visual check for hunting.
	During valve operation, look and listen for unusual noise or vibration.

### Handling Precautions:

- Avoid installing the valve where it will be subject to vibration or other external forces that may affect its performance.
- A packing (gasket) is attached to the cap of auxiliary equipment such as positioners.
- Do not lose it during wiring work.
- Take care not to lose screws for the cap of auxiliary equipment such as positioners.
- Make sure that the seal of cable glands and electrical conduits is sufficient to prevent the entry of moisture.
- Dispose of old parts that were replaced during valve disassembly or maintenance as industrial waste.  
If they are burned or discarded carelessly, environmental pollution will result.
- When assembling the valve, check that packings (gaskets) are in place and tighten screws evenly.

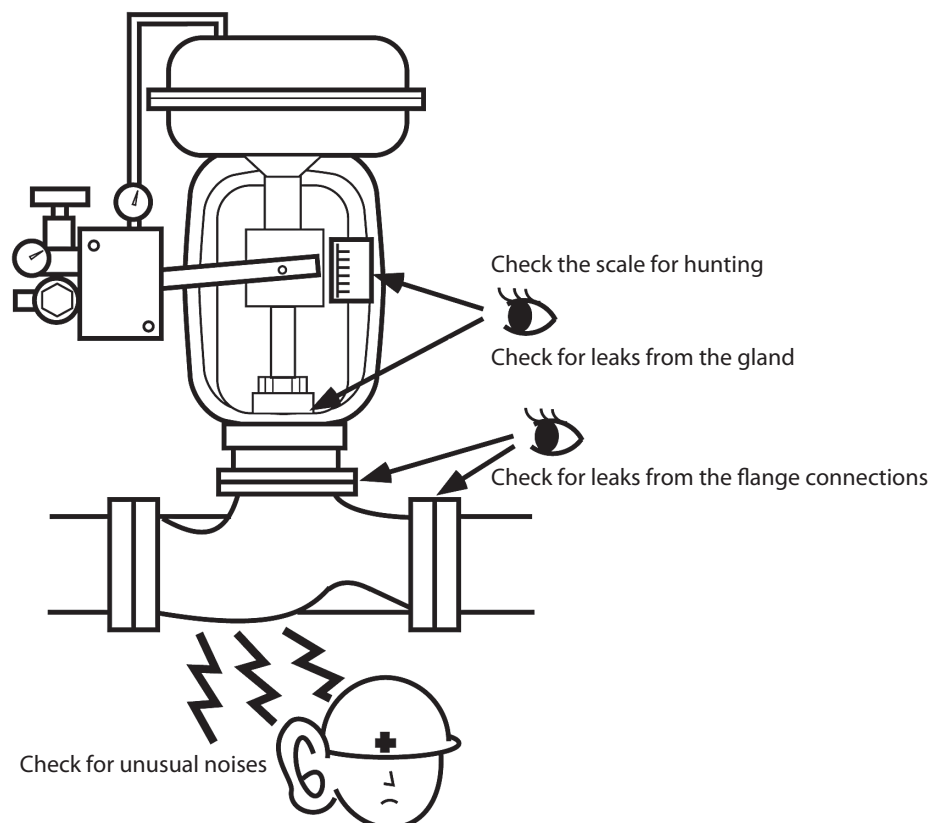

# Unpacking and Storing the Product

## Unpacking

This valve is a precision instrument. Take special care in handling the valve to prevent accidents, damage, etc.

When unpacking, check for the following items.

- The valve, actuator, and parts to be attached
- Any auxiliary devices that you ordered

## Checking the Specifications

Check that the fluid conditions, valve number (tag No.), and the specifications printed on the name plate are correct and appropriate. The name plate of the product is attached in the following position:

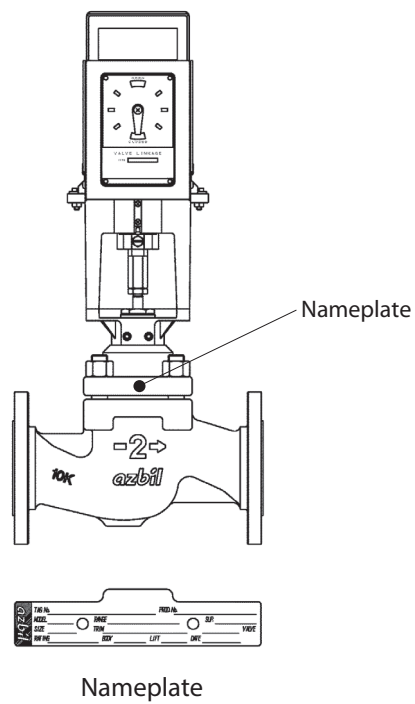

## Inquiries

For inquiries concerning this device, contact the azbil Group.

When making an inquiry, have your model number and product number ready.

## Precautions for Storage

Observe the following precautions in order to store the purchased valve properly.

- If the valve is packed in a cardboard box, store it indoors at room temperature and humidity.
- A valve packed in a wooden crate should also generally be stored indoors at room temperature and humidity. For outdoor storage, after unpacking the valve and checking the specifications, cover it with a polyethylene protective sheet to keep rainwater out.

To store a valve that has been used, follow the instructions below.

1. Wash out any fluid stuck to or remaining in the interior of the valve.
2. If it is likely that the valve will corrode, take preventive measures.
3. Cover the openings for electrical conduit connections with waterproof caps or tape to keep water out.

In addition, protect the threads on the connectors.

4. Protect the ends of piping connections (flanges, welded surfaces) using flange caps or the like.

# Table of Contents

Chapter 1. Structure of the Control System.....	1-1
1-1. Introduction.....	1-1
1-2. Control Valve Structure .....	1-2
1-3. Specifications of the Control Valve .....	1-3
1-4. External Dimensions and Weight.....	1-3
Chapter 2. Installation.....	2-1
2-1. Installation Location .....	2-1
2-2. Inspection before Installation .....	2-2
2-3. Installation on the Pipe .....	2-4
2-4. Wiring .....	2-7
2-5. Inspection after Installation and Precautions for Operation.....	2-10
Chapter 3. Operation.....	3-1
3-1. Trial-Run Inspection and Adjustment.....	3-1
3-2. Troubleshooting.....	3-2
Chapter 4. Maintenance.....	4-1
4-1. Inspection of the Control Valve.....	4-1
4-1-1. Daily Inspection.....	4-1
4-1-2. Periodic Inspection .....	4-2
4-2. Removing the control valve.....	4-3
4-3. Disassembling and Reassembling the Control Valve .....	4-5
4-3-1. Before Disassembly .....	4-5
4-3-2. Necessary Tools.....	4-5
4-3-3. Detaching the Actuator from the Valve Body.....	4-5
4-3-4. Disassembling the Valve Body.....	4-7
4-3-5. Reassembling the Valve Body .....	4-9
4-3-6. Mounting the Actuator on the Valve Body .....	4-12
Chapter 5. Disposal .....	5-1
Chapter 6. Maintenance Information.....	6-1
Appendix A Dimension and Weight.....	A-1
Appendix B List of Parts.....	B-1
Appendix C Main Parts to be Replaced.....	C-1



# Chapter 1. Structure of the Control System

## 1-1. Introduction

The NEW10-III is a control valve that is operated by relay contact input, potentiometer input, or 4–20 mA DC signals.

Figure 1-1 illustrates a typical control valve system.

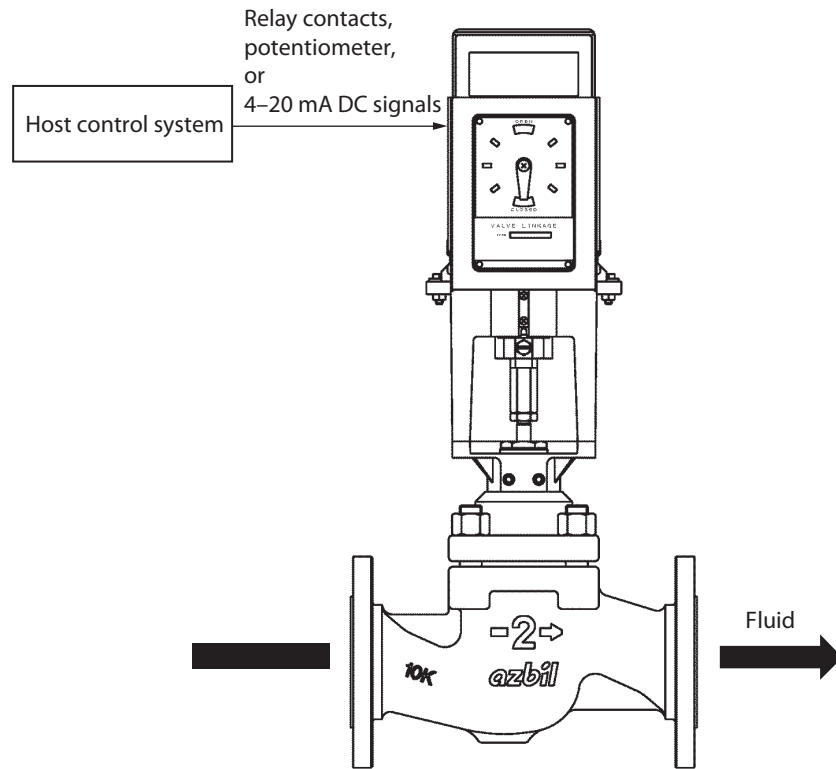

Fig 1-1. NEW10-III Control System

This manual contains operating instructions for the single-seated control valve, model ACT.

For details on the ECM3000 control motor, refer to the user's manual below.

- ECM3000 Control Motor User's Manual (CP-UM-5306E)

## 1-2. Control Valve Structure

This device is composed of a valve body and an actuator. The valve body consists of a valve, bonnet, valve plug, and other components. The actuator consists of a control motor, yoke, and other components. Fig 1-2 illustrates the structure of this device.

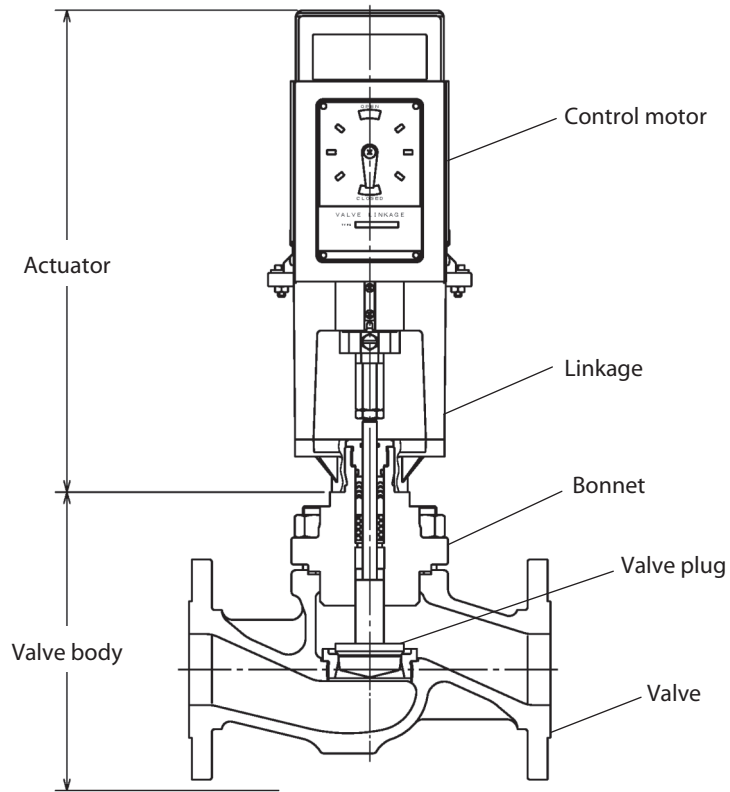

Fig 1-2. Structure



Names and functions of the components are described below.

Name	Function
Valve body	<ul style="list-style-type: none"> <li>· Controls fluid flow.</li> <li>· Connects to a pipe and contains all valve components.</li> </ul>
Valve plug	<ul style="list-style-type: none"> <li>· Regulates flow rate, pressure, etc. by changing the size of the flow area.</li> </ul>
Valve	<ul style="list-style-type: none"> <li>· The part through which the fluid flows. Connects to a pipe.</li> <li>· The main component of the pressure vessel</li> </ul>
Bonnet	<ul style="list-style-type: none"> <li>· Regulates the valve plug performance in accordance with a change in flow.</li> <li>· A component of the pressure vessel</li> </ul>
Actuator	<ul style="list-style-type: none"> <li>· Adjusts valve travel in accordance with the signal received.</li> </ul>

For details on the structure of the valve body, refer to page 4-8, Fig 4-2.



### 1-3. Specifications of the Control Valve

 <b>CAUTION</b>	
	The specifications of the control valve, such as the rated pressure and material of the valve body and trim material, are determined by the fluid conditions. The control valve must not be used for applications other than the application the valve is designed for. Failure to comply with this caution may result in burns or injuries due to high temperature or leakage of hazardous fluid.
	This control valve must be used in compliance with all applicable safety regulations, specifications, and standards.

Since the control valve contacts the process fluid, its specifications must be appropriate for the process conditions and the purpose of use.

### 1-4. External Dimensions and Weight











The external dimensions and weight of model ACT are given in Appendix A Dimension and Weight. Refer to Appendix A when installing the valve or for other work.



# Chapter 2. Installation

## 2-1. Installation Location

Please observe the following cautions when selecting the installation site for the control valve.

 <b>CAUTION</b>	
	Make sure that there is a straight pipe section at least 10 times the pipe diameter on the upstream side and 6 times the pipe diameter on the downstream side (D: nominal diameter). If the straight pipe sections are not long enough, insufficient valve capacity or unusual noise or vibration could result.
	Ensure sufficient space for easy and safe operation and maintenance of the control valve.
	Avoid installing the valve where it will be subject to vibration or other external forces that may affect its performance. If necessary, take appropriate measures.
	Provide appropriate support for the valve itself and for connected pipes to prevent an excessive load from the weight and operation of the valve. (Care is needed especially for large valves and valves for low-temperature fluid.)
	If the valve is installed along a passageway used by outsiders, install a fence or cover as a protective measure.
	Do not install the valve where it may be submerged by rainwater, covered with snow, or subject to freezing.
	If the valve is exposed to radiant heat, provide a shielding plate or the like.
	If the valve is exposed to salt or a corrosive atmosphere, take measures against corrosion.
	Keep in mind that the valve is heavy. In order to prevent an accident, always wear safety goggles, gloves, and safety shoes when handling the valve.

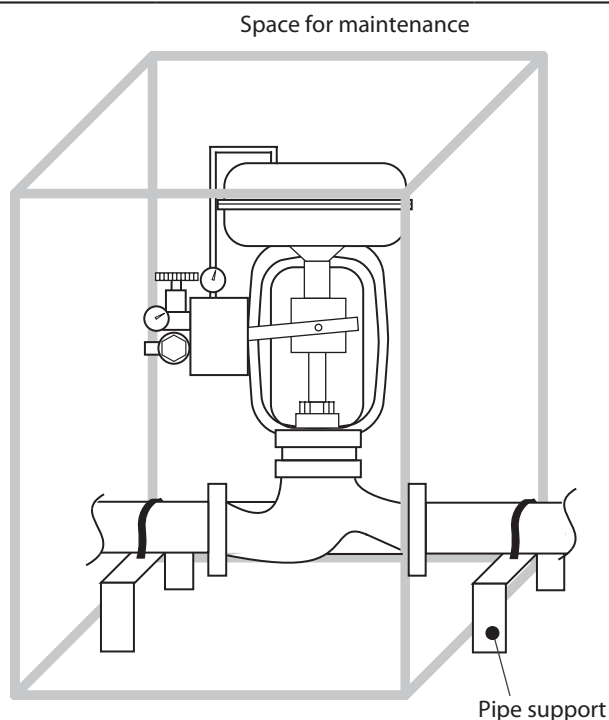









The control valve is designed to withstand severe operating conditions. However, in order to achieve its optimal performance, install the valve to a location with the following conditions:



- Ambient temperature: -20 to +60 °C
- Relative humidity: 5 to 95 % RH (without condensation)
- Vibration: 4.9 m/s<sup>2</sup>

## 2-2. Inspection before Installation

Observe the following precautions when installing the valve on the pipe.

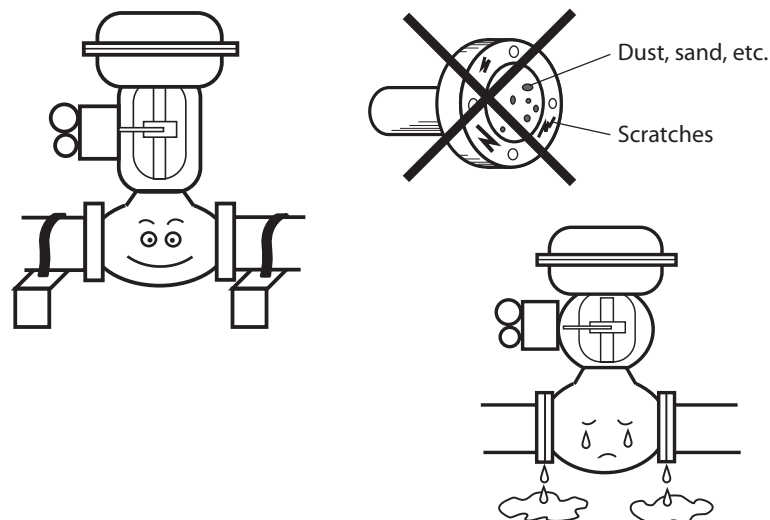
 <b>CAUTION</b>	
	Protective covers are attached to the flanges to protect the gasket-contacting surfaces and to prevent foreign matter from entering the valve. When installing the valve, remove the covers.
	Check that there is no damage to the valve (including the actuator and auxiliary equipment).
	Check that there is no damage to the flanges on piping connections.
	If the flange on the pipe has been welded, check that it has cooled sufficiently before proceeding with installation.
	Chamfer the edges of the pipe flanges.
	Remove foreign matter such as dust, sand, and welding spatter from the inside of the pipes, and clean the inside of the valve. Foreign matter may damage the valve seat and cause impaired closing performance.
	Check that the pipes on both sides of the valve are sufficiently supported. The valve's weight may cause leakage from flange connections.
	Check that the packing gland and bolts are firmly tightened. Loosening of the packing gland bolt may cause leakage from the gland.



 <b>WARNING</b>	
	If the rated pressure or standards for connection are ignored when this device is used, damage to the product or leakage may cause a serious accident.

Check the following before installing the model ACT control valve on the piping.

1. The specifications printed on the name plate are appropriate for the use.
2. There is no damage to the valve (including the actuator and auxiliary equipment).
3. There is no damage to the flanges on the piping.
4. The piping can support the weight of the control valve (refer to 表 A-1).

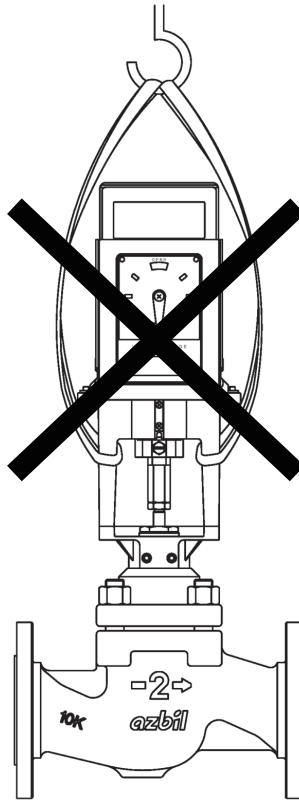

**! WARNING**









When moving or transporting the control valve, do not lift the valve with a cable through the valve linkage.  
If the valve falls, an injury or valve damage may result.







The weight of this device is 18 kg or more, depending on the model.  
When moving or transporting the valve, use a cart, etc., or carry it with 2 or more people.  
Carelessly lifting the valve and accidentally dropping it can cause injury or damage.

## 2-3. Installation on the Pipe

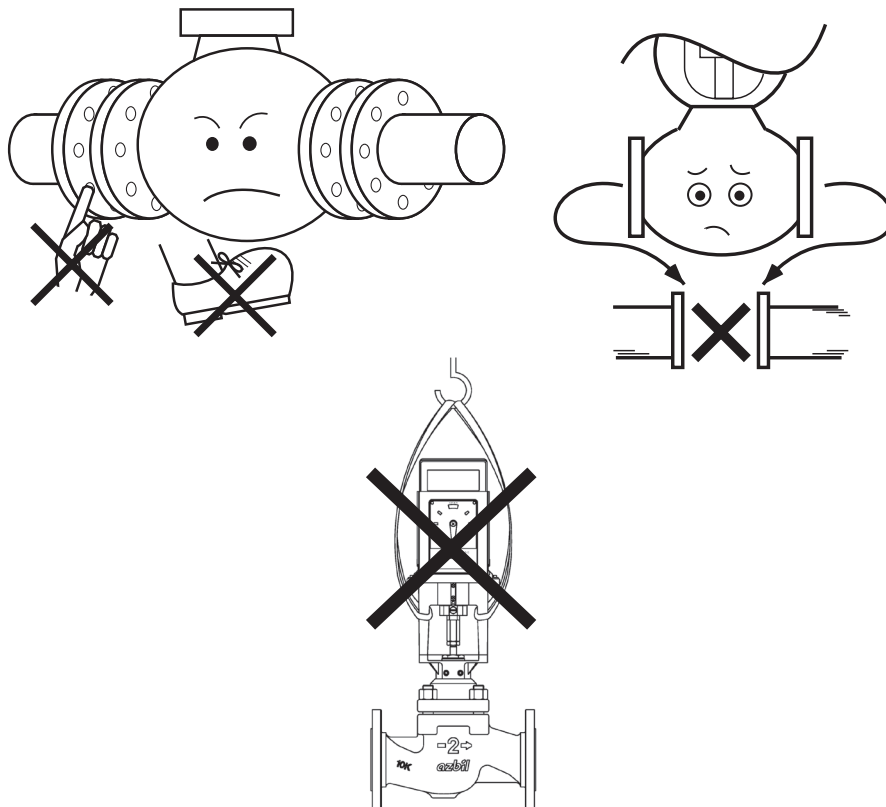
<Installation>

 <b>CAUTION</b>	
	Check that the pipes on both sides of the valve are properly aligned. Misalignment of the pipes will put a strain on the valve and may cause fluid leakage from the connections (gaskets).
	Check that the distance between the pipe flanges is equal to the total of the face-to-face length of the valve and the thickness of the gaskets.
	Use nuts and bolts that comply with the standards for the flange. Otherwise fluid leakage may result.
	Use new flange gaskets that are appropriate for the fluid properties, operating temperature, and pressure. Damaged gaskets may cause fluid leakage.
	Open the valve fully before flushing the inside of the piping, and do not change the valve travel while the pipes are being flushed. Otherwise, the valve may be damaged by welding spatter or other foreign matter.
	Do not keep the bonnet in a damp or cold condition. Doing so may cause fluid leakage from the gland.



 <b>WARNING</b>	
	When connecting the valve to the piping, never put your hand or foot under the valve or between the flanges. You may lose your fingers or your foot may be injured.
	Before reinstalling the valve after maintenance or modification, wash out any residual fluid in the pipes or replace it with a safe fluid. Otherwise, the residual fluid may cause an injury.

(1) Standard installation

Fig 2-1 illustrates standard installation.

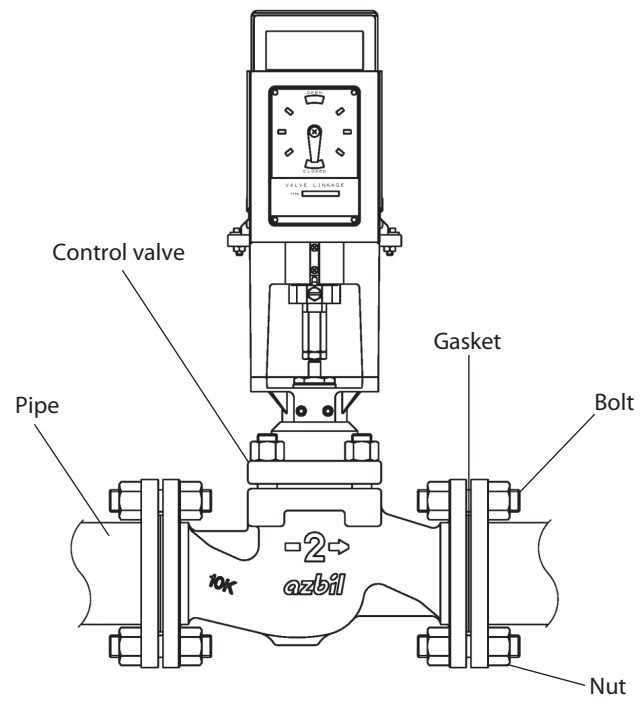
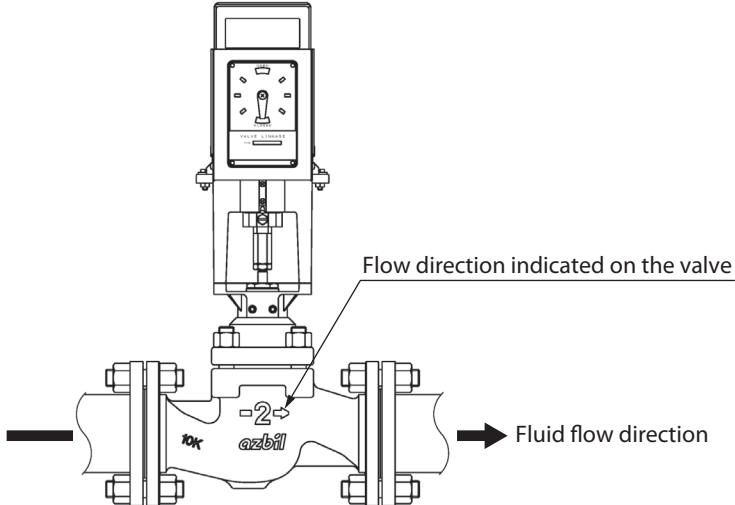
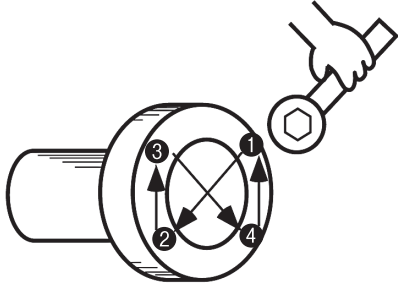







Fig 2-1. Installation on the pipe

(2) Installation procedure

Step	Procedure
1	<p data-bbox="518 264 1394 331">Check that the flow direction of the process fluid is the same as the direction indicated on the control valve.</p> <div data-bbox="625 344 1362 846"><p>The diagram shows a control valve assembly. At the top is a control box with a dial. Below it is the valve body, which has two flanges on either side. A line with an arrow points to the valve body with the text "Flow direction indicated on the valve". Another line with an arrow points to the right side of the valve with the text "Fluid flow direction". The valve body has the number "2" and the brand name "azbil" on it.</p></div> <p data-bbox="703 860 1206 891">Fig 2-2. Flow direction indicated on the valve</p>
2	<p data-bbox="518 907 1394 974">Attach the valve and gaskets to the pipes. Loosely tighten the nuts of the flange bolts.</p>
3	<p data-bbox="518 996 1394 1064">Make sure that the gaskets do not protrude into the flow path and constrict the inner diameter of the valve.</p>
4	<p data-bbox="518 1086 1394 1153">Tighten the bolts and nuts for the flanges evenly and securely in a diagonal pattern (refer to Fig 2-3).</p> <div data-bbox="762 1160 1161 1444"><p>The diagram shows a top-down view of a flange with four bolts. A hand is shown using a wrench to tighten one of the bolts. The bolts are numbered 1, 2, 3, and 4 in a diagonal pattern: 1 is at the top-right, 2 is at the bottom-left, 3 is at the top-left, and 4 is at the bottom-right. Arrows indicate the direction of tightening for each bolt.</p></div> <p data-bbox="730 1451 1182 1482">Fig 2-3. Tightening in a diagonal pattern</p>
5	<p data-bbox="518 1505 1394 1572">After installation is complete, check that all bolts and nuts are securely tightened and there is no leak from the piping.</p>



## 2-4. Wiring

 <b>CAUTION</b>	
	Wiring should be carried out only by qualified technicians and should comply with local electrotechnical standards.
	Cabling should be carried out in accordance with facility conditions. Use an adapter (and packing) whose size is appropriate for the outer diameter of the cable.
	Avoid doing wiring work on a rainy day or in high humidity. Moisture inside connectors or the terminal box may cause a short-circuit or rust.
	Seal the cable gland and electrical conduit threads well to prevent the entry of moisture.

Open the knockout hole (dia. 22 mm) on the side of the valve for the wiring.  
Connect the wires to the terminals, referring to the labels on the terminal block. Be sure to use M3.5 crimp terminals with insulating sleeves.  
For detailed instructions on handling the ECM3000 control motor, refer to the user's manual indicated in chapter 1.

### **Handling Precautions:**

- To open the knockout hole, place a screwdriver on the rim of the hole and give several taps.
- Make sure that no fragments from opening the knockout hole enter the device.
- Do not use terminals that are not in use as relay terminals.
- Be sure to attach the terminal cover after wiring is complete.
- Do not run power wires and signal wires in the same conduit.
- Leave 50 cm or more between power wires and signal wires.
- Connect a power source with the appropriate voltage for the model.
- Be sure to install a breaker on the power supply.
- When operating the control motor, set the parameters of the control valve so that the valve's built-in relays do not turn on and off excessively due to hunting (for example, set derivative time (D) = 0, or set a wider deadband).  
Excessive operation will shorten the service life of the motor and upstream relays or built-in relays of the connected control valve.

### • **Wires**

For the power wires, use a JIS C 3307 600 V PVC-insulated wire or equivalent.  
For signal wires, use a JCS 4364 cable for low-power electrical instruments or equivalent.

● **Relay contact input (power: 24 V AC)**

Model number:  
ECM3000D0\_\_0  
ECM3000F0\_\_0

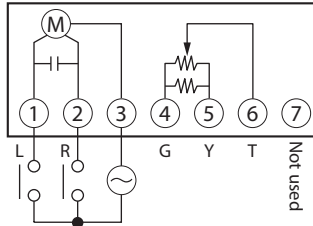

L: Operation direction: CCW (counterclockwise)  
R: Operation direction: CW (clockwise)

! **Handling Precautions:**

- For on-off operation, terminals 4, 5, and 6 are not used.

● **Potentiometer (135 Ω) input (power: 24 V AC)**

Model number:  
ECM3000E0\_\_0

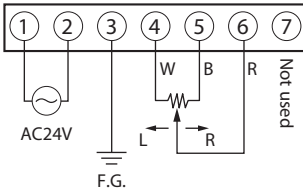

L: Operation direction: CCW  
R: Operation direction: CW

To change operation direction, attach wires to terminals 4 and 5 vice versa.

● **4–20 mA input (power: 24 V AC)**

Model number:  
ECM3000G0\_\_0

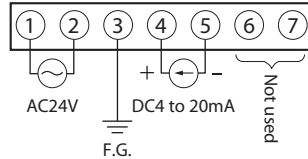

Note: The 4–20 mA input circuit and the power supply circuit are isolated.

● **Relay contact input (power: 100/200 V AC)**

Model number:  
ECM3000F1\_\_0  
ECM3000F2\_\_0

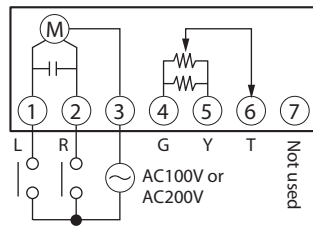

L: Operation direction: CCW  
R: Operation direction: CW

! **Handling Precautions:**

- For on-off operation, terminals 4, 5, and 6 are not used.
- When operating the control motor, set the parameters of the control valve so that the valve's built-in relays do not turn on and off excessively due to hunting (for example, set derivative time (D) = 0, or set a wider deadband).
- Excessive operation will shorten the service life of the motor and upstream relays or built-in relays of the connected control valve.  
If excessive operation is unavoidable, install an auxiliary relay between the motor and the control valve.

● **4-20 mA input (power: 85-264 V AC)**

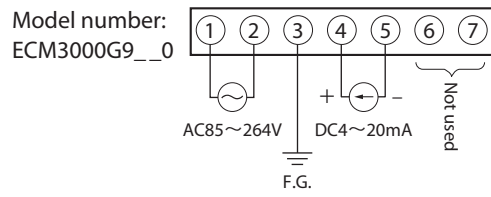

Note: The 4-20 mA input circuit and the power supply circuit are isolated.

## 2-5. Inspection after Installation and Precautions for Operation

### <Cautions>

- Make sure that the bolts and nuts of the bonnet, etc., are firmly tightened.
- An increase in the valve's temperature should be made gradually (100 °C / hr or less).  
Avoid operating the valve while its temperature is increasing.
- After applying pressure to the valve, check for leakage from the valve body, gland packing, and gaskets, and tighten each part further in preparation for long-term use.  
Use the torques indicated in page 4-10, Table 4-1 to 4-3.

## **Chapter 3. Operation**

### **3-1. Trial-Run Inspection and Adjustment**

(1) Operation test

For models that operate on 4–20 mA DC input, send dummy input signals (0 to 100 %) to the device to check that the valve travel indicated in the specifications is achieved.

\* Page 1-1

### 3-2. Troubleshooting

Problems that might occur during operation are described in Table 3-1. Take necessary measures such as replacing parts, depending on the circumstances.

**Table 3-1. Control valve problem causes and countermeasures**

Phenomenon		Cause	Countermeasure
Unreliable valve operation	The valve hunts near the fully closed position.	The valve capacity is too large.	<ul style="list-style-type: none"> <li>Reduce the differential pressure between the primary and secondary sides of the valve.</li> <li>Replace the valve trim with trim that has a smaller Cv.</li> </ul>
		The fluid flows in the direction that makes the valve close.	<ul style="list-style-type: none"> <li>Check that the flow direction indicated on the valve is the same as the fluid direction. If not, change the direction.</li> </ul>
	The valve hunts even though the signal is steady.	Unbalance due to fluctuation in fluid pressure resistance or in axial thrust	<ul style="list-style-type: none"> <li>Reduce the differential pressure between the inlet and outlet of the valve.</li> <li>Replace the actuator with one that has more rigidity.</li> <li>Add a positioner</li> </ul>
Valve vibration	The valve vibrates at any travel.	Insufficient support for the piping	<ul style="list-style-type: none"> <li>Support the inlet and outlet of the valve.</li> </ul>
		There is a source of vibration around the valve.	<ul style="list-style-type: none"> <li>Remove the source of vibration.</li> </ul>
		The guide is worn out.	<ul style="list-style-type: none"> <li>Replace the guide bushing and/or the valve plug.</li> </ul>
Slow valve stroke	Valve stroke is slow in both opening and closing directions.	The valve plug guide, the fluid retaining part of the bonnet, etc., is clogged with slurry.	<ul style="list-style-type: none"> <li>Disassemble and clean.</li> <li>Install a steam jacket on the valve body.</li> </ul>
		The gland packing is hardened.	<ul style="list-style-type: none"> <li>Replace the gland packing or the grease.</li> </ul>
Valve not operating	The actuator does not operate.	The power is off.	<ul style="list-style-type: none"> <li>Turn on the power.</li> </ul>
		Wires were cut off or terminals are loosely attached to the terminal box.	<ul style="list-style-type: none"> <li>Replace the wires and attach terminals securely to the terminal box.</li> </ul>
		The supply voltage is incorrect or lower than the voltage defined in the specifications.	<ul style="list-style-type: none"> <li>Test the voltage at the terminals.</li> </ul>
		The thermal protector was activated (the ambient temperature is high or a part of the valve affected by the load, such as the guide, is locked).	<ul style="list-style-type: none"> <li>Lower the ambient temperature.</li> <li>Check the operation of the valve manually.</li> </ul>
		Actuator failure	<ul style="list-style-type: none"> <li>Replace the actuator.</li> </ul>
	The valve does not operate even though the actuator is powered.	The valve stem, valve plug guide, etc., is stuck due to heat or foreign matter.	<ul style="list-style-type: none"> <li>Disassemble and inspect the valve body, and reprocess or replace the valve stem or guide bushing with new ones.</li> </ul>
		Foreign matter is caught in the valve plug.	<ul style="list-style-type: none"> <li>Disassemble, inspect, and clean the valve body.</li> </ul>
		The valve stem is bent.	<ul style="list-style-type: none"> <li>Repair the valve stem.</li> </ul>
	Actuator failure	<ul style="list-style-type: none"> <li>Check the operation of the actuator.</li> </ul>	

**Table 3-1. Control valve problem causes and countermeasures (continued from the previous page)**

	Phenomenon	Cause	Countermeasure
Valve does not fully open / leakage from the valve interior in large amounts	The valve stem is at the valve fully-open position.	The valve plug and/or the seat ring is corroded, eroded, abraded, or otherwise damaged.	<ul style="list-style-type: none"> <li>· Lap the valve plug and seat</li> <li>· Re-machine the valve plug and seat.</li> <li>· Replace the valve plug or/and the seat ring (consider using hardened parts)</li> </ul>
		Parts on the outer circumference of the seat ring (thread or gasket) are corroded or eroded.	<ul style="list-style-type: none"> <li>· Replace the seat ring or the gasket.</li> <li>· Use a different mounting method for the seat ring (e.g., welding).</li> </ul>
		The fluid leaks from the partition of the valve body.	<ul style="list-style-type: none"> <li>· Weld pinholes.</li> <li>· Replace the valve body.</li> </ul>
	The valve stem does not reach the fully closed position.	The differential pressure of the fluid is too great.	<ul style="list-style-type: none"> <li>· Increase the output from the actuator.</li> </ul>
		Foreign matter is caught in the valve stem.	<ul style="list-style-type: none"> <li>· Disassemble, inspect, and clean the valve body.</li> </ul>
		The valve stem, valve plug guide, etc., is stuck due to heat	<ul style="list-style-type: none"> <li>· Separate these parts.</li> </ul>
	Fluid leaks from the gland packing.	Looseness of the gland packing or bolts	<ul style="list-style-type: none"> <li>· Tighten the gland packing or bolts.</li> </ul>
		Grease depleted (for asbestos yarn packing)	<ul style="list-style-type: none"> <li>· Replenish the grease.</li> </ul>
		The gland packing has deteriorated.	<ul style="list-style-type: none"> <li>· Replace the gland packing (consider using a packing of a different material)</li> </ul>
		The valve stem, interior of the packing box, etc., is damaged, corroded, or eroded.	<ul style="list-style-type: none"> <li>· Attach a felt ring or rubber bellows to protect the valve stem (if there is a lot of foreign matter).</li> </ul>
The fluid leaks from the gasket.	The gasket is damaged, corroded, or eroded.	<ul style="list-style-type: none"> <li>· Replace the gasket (consider using a gasket of a different material)</li> </ul>	
The amount of valve travel or the control rangeability have narrowed	The valve characteristic has changed because the valve plug is corroded, eroded, or abraded.	<ul style="list-style-type: none"> <li>· Replace the valve plug, seat ring, etc. (consider using parts of a different material for better corrosion-resistance and rigidity)</li> </ul>	





# Chapter 4. Maintenance

## 4-1. Inspection of the Control Valve

Check the control valve in accordance with the following instructions in order to maintain proper performance, prevent accidents, and detect problems early.

Daily inspection and periodic inspection (overhaul) must be carried out.

For instructions on handling the ECM3000 control motor, refer to the user's manual indicated in chapter 1.

### 4-1-1. Daily Inspection

The following items should be checked in daily inspections of the equipment.

< Checklist >

(1) Gland

Check for a fluid leak from the gland. If a leak is found, take necessary measures, referring to 3-2. Troubleshooting.

(2) Flange connections

Check the flange between the valve body and the bonnet, and the flange between the valve body and the piping, for fluid leakage. If a leak is found, take necessary measures, referring to 3-2. Troubleshooting.



(3) Control valve operation

Check for any abnormal operation such as hunting. If the valve is hunting, take necessary measures, referring to 3-2. Troubleshooting.

(4) Abnormal noise or sound

Check that there is no abnormal sound or vibration from the device during operation. If any problem is found, take necessary measures, referring to 3-2. Troubleshooting.

<b>⚠ WARNING</b>	
	If fluid leakage from the valve is found, stay away from the valve until safety can be confirmed. Depending on the properties of the fluid, a serious accident or injury may result.

<b>⚠ CAUTION</b>	
	Check the gland daily for leakage.
	Check valve operation daily for hunting.
	Check that there is no abnormal sound or vibration from the device during operation.

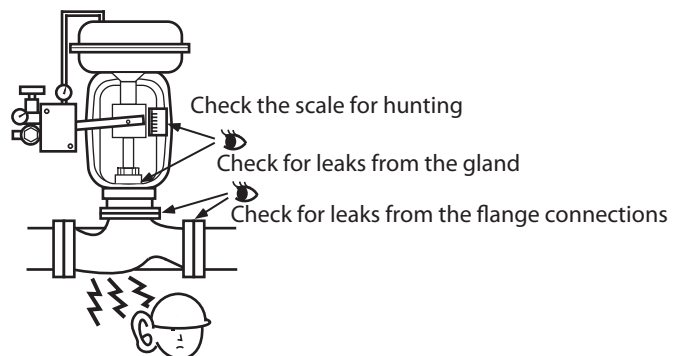

## 4-1-2. Periodic Inspection

Disassemble the control valve once every two or three years. Replace consumables and repair or replace any parts that have deteriorated. When disassembling the valve, be sure to observe the instructions in 4-3. Disassembling and Reassembling the Control Valve.

### < Recording inspection results >

Recording the results of periodic inspection on the following items is recommended. The records will be useful in estimating the remaining service life of the product, troubleshooting, identifying consumables that should be replaced, and in other various circumstances.

### < Precautions >

- Before uninstalling the control valve from the equipment, check that removal of the valve will not affect the performance of the equipment.
- When disassembling the control valve, refer to < Precautions > in 4-3-4. Disassembling the Valve Body and take necessary notes for reassembly of the valve.
- Before disassembling the control valve, send dummy inputs to the actuator or the positioner to check for any problems.

### < Checklist >

- (1) Appearance  
Check the diaphragm case, waterproof cap, yoke, stem connector, bonnet, valve, bolts, nuts, and air piping for damage or corrosion, and check that all necessary parts are attached. In addition, check if the paint is worn out.
- (2) Damage to stems  
Check the valve stem and actuator stem for damage.
- (3) Leakage from the valve and bonnet connection  
Check the connection between the valve and bonnet for any signs of leakage.
- (4) Leakage from the gland  
Check the gland for any signs of leakage.
- (5) Damage to the valve plug and seat ring seats  
Check the valve plug and seat ring seats for damage or deterioration such as corrosion that will cause a leak from the valve seat. If a problem is found, lap, re-machine, or replace the part.
- (6) Damage to the guide caused by foreign matter  
Check the guide for the valve plug and the guide in the bonnet for burrs, deformation, and damage caused by foreign matter. If a problem is found, repair or replace the part.
- (7) Scaling in the valve  
Check the valve, valve plug, inside surface of the bonnet, gland box, seat ring, etc., for scaling. Remove any scaling that has accumulated in the valve.
- (8) Damage or corrosion on the inside of the gland box  
Check the gland box for damage or deterioration such as corrosion that will cause a leak from the gland. If such problem is found, re-machine or replace the part.
- (9) Damage or corrosion on the gasket-contacting surface  
Check the gasket-contacting surface of the valve and bonnet for damage or deterioration, such as corrosion that will cause a leak. If a problem is found, repair, re-machine, or replace the part.

## ⚠ CAUTION



Dispose of old parts that were replaced during valve disassembly or maintenance as industrial waste. If they are burned or discarded carelessly, environmental pollution will result.

### 4-2. Removing the control valve

This section provides instructions for removing the control valve from the equipment for a periodical inspection or other purposes.

Refer to the following instructions or cautions when removing the valve.

< Before beginning >

- Allow enough space to work.
- Check that removal of the valve will not affect the performance of the equipment.
- Be sure to shut off the fluid in the piping and release the process pressure.
- Check that the temperature near the control valve is safe.
- If you use the eyebolts on the actuator to lift up the control valve, remove all the bolts at pipe connections to avoid applying excessive force to the eyebolts.

< Removing the control valve >

(1) Removing wires

Shut off all signals and power from electric equipment that is connected to the control valve, and remove the wires.

Refer to the instructions in page 2-7, 2-4. Wiring .

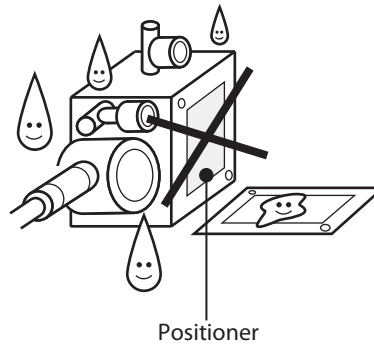

## ⚠ CAUTION



Wiring work should be carried out only by qualified technicians following local electrotechnical standards.



Avoid doing wiring work on a rainy day or in high humidity. Moisture inside the connectors or the terminal box may cause a short-circuit or rust.



A packing (gasket) is attached to the cap of the control motor. Do not lose it during wiring work.



Take care not to lose screws for the cap of the control motor. When assembling the valve, check that the packing (gaskets) are in place and tighten the screws evenly.



Make sure that the seal of cable glands and electrical conduits is sufficient to prevent the entry of moisture.

(2) Removal from the piping

Secure the control valve by slinging or by other means.

Then, remove bolts and nuts from the flanges and detach the control valve from the piping.

**⚠ CAUTION**



If the eyebolts (eyenuts) attached to the actuator are used to lift the valve, make sure that the weight does not exceed the limit specified in the user's manual. An excessive load may damage the actuator or cause air leakage.



When connecting the valve to the piping, never put your hand or foot under the valve or between flanges. You may lose your fingers or your foot may be injured.

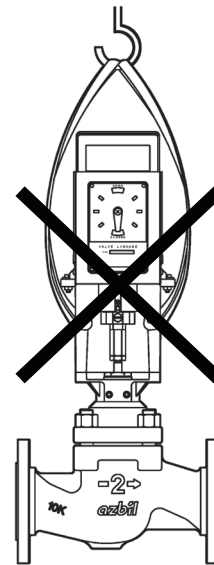
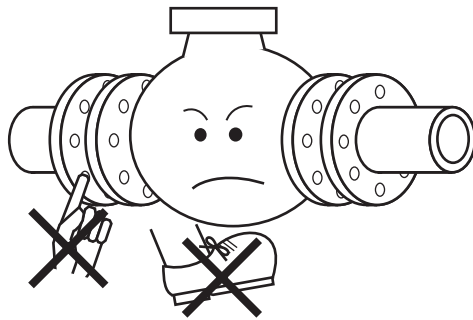

**⚠ WARNING**



When moving or transporting the control valve, do not lift the valve with a cable through the valve linkage.

If the valve falls, an injury or valve damage may result.



The weight of this device is 18 kg or more, depending on the model.

When moving or transporting the valve, use a cart, etc., or carry it with 2 or more people. Carelessly lifting the valve and accidentally dropping it can cause injury or damage.

### 4-3. Disassembling and Reassembling the Control Valve

This section gives instructions on disassembly and reassembly of the control valve. If you need to disassemble and reassemble the valve for periodic inspection, troubleshooting, or other circumstances, refer to the instructions.

#### 4-3-1. Before Disassembly

- Allow enough space to work. If you disassemble several control valves at the same time, allow extra space to avoid mixing parts up.
- If you detach only the actuator, leaving the control valve on the piping, be sure to shut off the fluid in the piping and release the process pressure.
- Check that the temperature near the control valve is normal.
- Have all tools necessary for disassembly or detachment ready.
- Take notes of the information printed on the name plate.

#### 4-3-2. Necessary Tools

A hammer, chisel, punch, open-end wrench or box wrench, and any special tools (e.g., a wrench for the seat ring). Contact us for a special wrench for the seat ring.

#### 4-3-3. Detaching the Actuator from the Valve Body

< Procedure >

Step	Procedure
1	Marking Place matching marks as indicated in Fig 4-1 in order to reassemble the control valve with the actuator, valve, and bonnet in the same place.
2	Detaching the actuator from the valve body Loosen and remove the screws for the stem connector with a screwdriver. Loosen and remove the 4 hex socket head set screws under the linkage. Lift the actuator to complete detachment.
3	Removing the stem connector Loosen the hex nut at the bottom of the stem connector, and remove the stem connector and the nut.

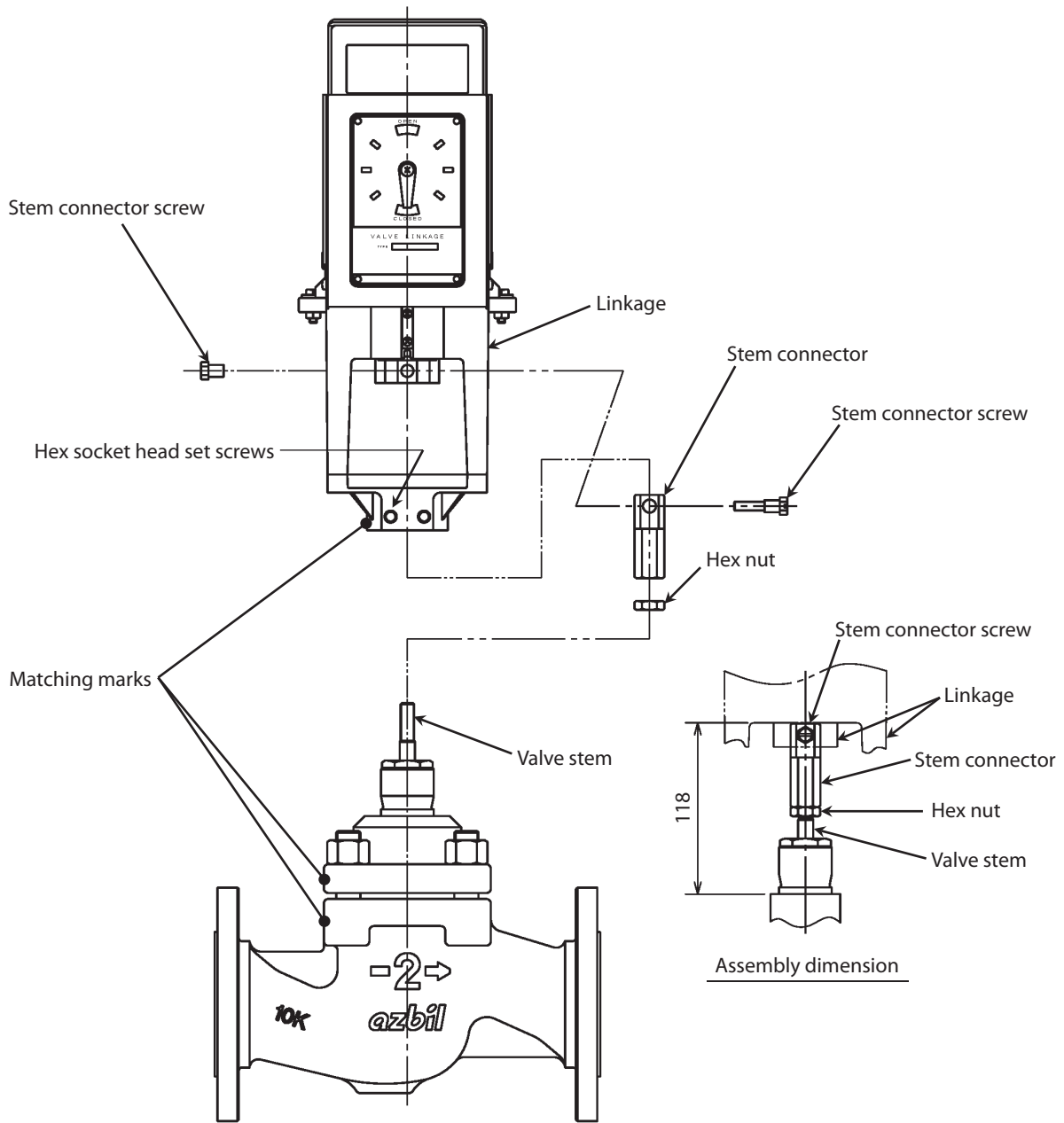







Fig 4-1. Disassembly and reassembly of the control valve

### 4-3-4. Disassembling the Valve Body

< Precautions >

- Disassemble the valve body on a rag, etc., to avoid damaging the valve.
- After disassembling the valve body, protect the gasket-contacting surfaces, the valve plug seat, sliding areas, seat ring, etc.

 <b>WARNING</b>	
	Before disassembling the valve body, check that the pressure in the valve has dropped to atmospheric pressure. If fluid spews out, injury may result.
	Before disassembling the valve body, wash out the inside the valve or replace the fluid. Otherwise, the residual fluid may cause an injury.

 <b>CAUTION</b>	
	Dispose of old parts that were replaced during valve disassembly or maintenance as industrial waste. If they are burned or discarded carelessly, environmental pollution will result.

< Procedure >

Check the nominal diameter of the pipe connection of the control valve, and disassemble the valve referring to Fig 4-2. Valve body structure and Table 4-1 to 4-3.

(1) Detaching the bonnet from the valve

<b>Step</b>	<b>Procedure</b>
1	Loosen the nut for the packing.
2	With the open-end wrench or box wrench, loosen the hex nuts that hold the bonnet to the valve.
3	Move the bonnet up and down to check if the pressure in the valve has been released completely. Remove the nuts.
4	Remove the bonnet from the valve. Be sure to lift the bonnet vertically so that the valve stem does not move to the side. If the valve plug comes off along with the bonnet, turn the plug to remove it from the bonnet, taking care not to damage the stem.
5	Remove the gasket between the valve and the bonnet.

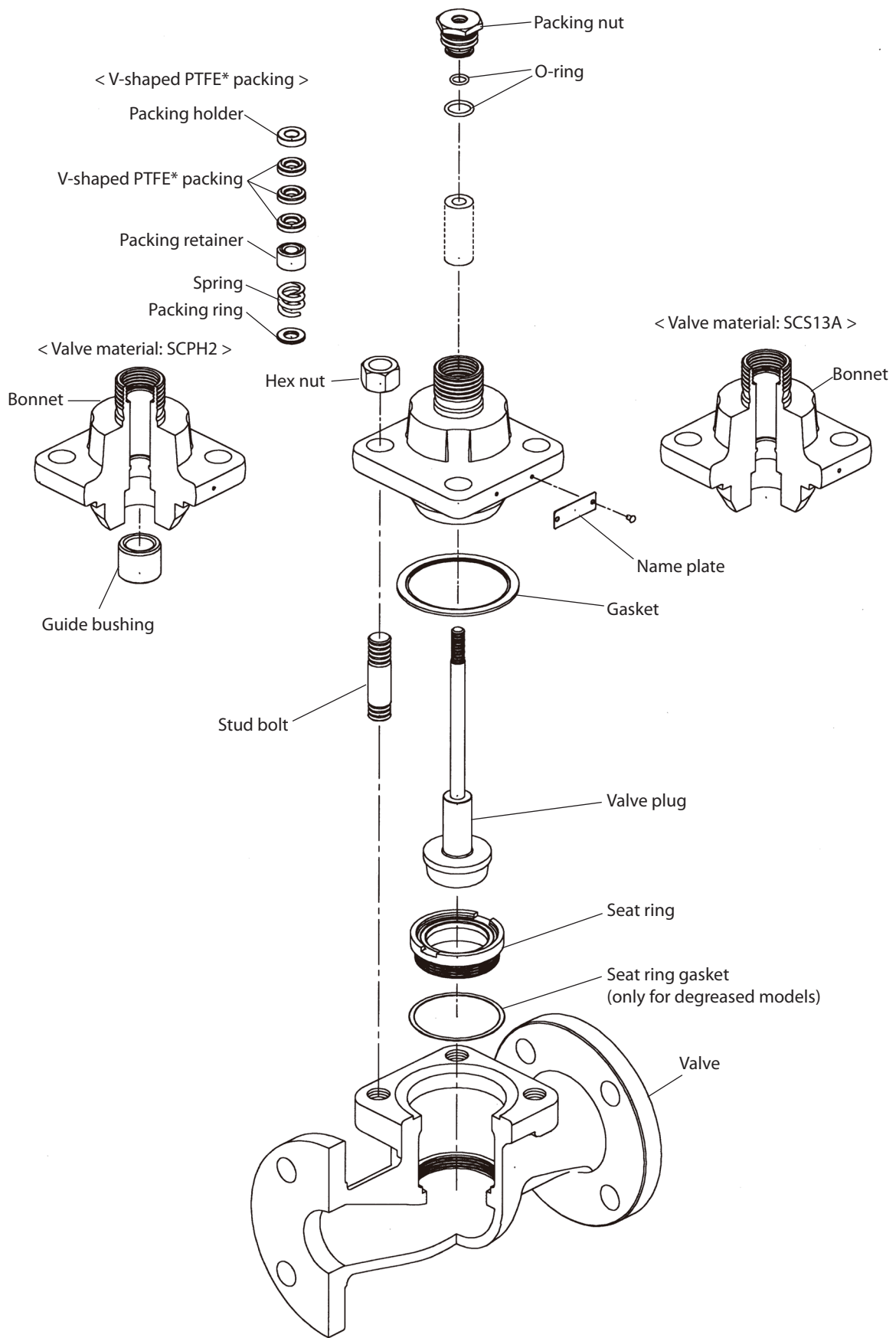

Fig 4-2. Valve body structure



(2) Removing the trim

After removing the valve plug, remove the seat ring with the special wrench for the seat ring.

(3) Taking out the gland parts

Take out the gland parts with a pipe, etc. Take notes of the type, quantity, order, etc., of parts such as the packing and spacers in order to facilitate reassembly.

 <b>CAUTION</b>	
	Use the special seat ring wrench to remove the trim (internal valve). Otherwise, the trim may be damaged.

### 4-3-5. Reassembling the Valve Body

< Precautions >



- Check that there is no problem with the parts, referring to <Checklist> in 4-1-2. Periodic Inspection. If a problem is found, repair or replace the part as needed.
- Always use new gland packing and gaskets.
- Note that the quantity, stacking order and direction of packing differs depending on the type of packing and fluid conditions.
- Check that foreign matter produced by maintenance do not remain inside the valve.
- For washing-restricted models (e.g., degreased or waterproof models), additional materials and sealing material with special specifications are required. Please refer to the specifications.

< Procedure >

Check the nominal diameter of the pipe connection of the control valve, and reassemble the valve referring to page 4-8, Fig 4-2. Valve body structure and Table 4-1 to 4-3.

(1) Mounting the seat ring

Step	Procedure
1	Screw the seat ring into the valve with your hand. For a model with standard specifications, apply an agent to prevent galling*1 to the screws and between the valve and seat ring. For a degreased model, use a seat ring gasket. Apply lubricant*2 to the said locations, position the seat ring gasket, and screw the seat ring into the valve.
2	Place the special seat ring wrench on the valve, and tighten the seat ring to the torque specified in Table 4-1 (page 4-9).

 <b>CAUTION</b>	
	Use the special seat ring wrench. when mounting the trim (internal valve).

\*1. Use Never-Seez made by the U.S. company Bostik or the equivalent.

\*2. Use GPL 207 made by Krytox or the equivalent.

**Table 4-1. Seat ring tightening torque**

[Unit: N·m]

Nominal size (inches)	Seat ring tightening torque
1/2, 3/4, 1	140
1-1/2, 2	210
2-1/2, 3	340

**Table 4-2. Bonnet hex nut tightening torque**

[Torque unit: N·m]

Nominal size (inches)	Bonnet hex nut	Tightening torque
1/2, 3/4, 1	M10	40
1-1/2, 2	M16	100
2-1/2, 3	M16	100

**Table 4-3. Screw gland tightening torque**

[Torque unit: N·m]

Valve stem size	V-shaped PTFE* packing tightening torque
φ10	1.6

\* Polytetrafluoroethylene

(2) Lap the contacting surfaces

Lap the mating valve plug and the seat ring surfaces.

Step	Procedure
1	Put an old gasket in place on the valve.
2	Apply a small amount of compound to the surface of the seat ring where the valve plug makes contact.
3	Insert the valve plug into the bonnet, and mount the bonnet on the valve loosely with stud bolts and nuts.
4	To keep the stem at the center during lapping, insert old packing into the gland.
5	Press the valve plug gently onto the seat ring and turn the plug to lap it (if you attach the stem connector to the top of the valve plug, you can use it as a knob). Remove the bonnet and valve plug from the valve, and check that there are no fine scratches, etc., on the surface.
6	When lapping is complete, wipe off the compound. Remove the stem connector, old packing, and old gasket.

(3) Assembling the valve plug and bonnet

Step	Procedure
1	Apply an agent for preventing galling*1 to a new gasket and set the gasket on the valve in place.
2	Insert the valve plug into the bonnet, then place the bonnet on the valve. Be sure to align the matching marks, which were placed before disassembly, in order to set the bonnet in the right position.
3	Apply an agent for preventing galling*1 to the threads of the stud bolts. Mount the bonnet on the valve and tighten the nuts using a wrench. Be sure to tighten the nuts evenly in a diagonal pattern to prevent uneven compression of the bonnet and to keep the valve stem centered.
4	<p>When done, all the nuts should be tightened to the torque specified in Table 4-2 (page 4-11).</p> <div style="border: 1px solid black; padding: 5px;"> <p style="text-align: center;"><b>⚠ CAUTION</b></p> <ul style="list-style-type: none"> <li style="border-bottom: 1px solid black; padding: 5px 0;"><b>!</b> When reassembling the valve body, always use new packing and gaskets. The reuse of old parts will cause fluid leakage.</li> <li style="border-bottom: 1px solid black; padding: 5px 0;"><b>!</b> Observe the tightening torques indicated in this user's manual when tightening bolts and nuts. Damaged or corroded bolts and nuts may damage the valve and cause injury, so they should be replaced with new ones.</li> <li style="padding: 5px 0;"><b>!</b> Tighten the nuts for connecting the bonnet to the valve evenly in a diagonal pattern.</li> </ul> </div>

\*1. For a model of standard specifications, use Never-Seez made by the American company Bostik or the equivalent. For a degreased model, use GPL 207 made by Krytox or the equivalent.

(4) Assembling the gland

Step	Procedure
1	Insert the parts of the gland in the right order, referring to the notes that were taken during disassembly and to the figure in Fig 4-2 (page 4-8), which illustrates the structure of the gland. Insert the parts all the way to the bottom with a pipe, etc.
2	<p>Apply an agent to prevent galling*1 to the packing nut, and then tighten it with the torque specified in Table 4-10 (page 4-10).</p> <div style="border: 1px solid black; padding: 5px;"> <p style="text-align: center;"><b>⚠ WARNING</b></p> <ul style="list-style-type: none"> <li style="padding: 5px 0;"><b>!</b> Observe the tightening torques indicated in this user's manual when tightening bolts and nuts. Damaged or corroded bolts and nuts may damage the valve and cause injury, so they should be replaced with new ones.</li> </ul> </div>

\*1. Use Never-Seez made by Bostik or the equivalent.

### 4-3-6. Mounting the Actuator on the Valve Body

<Procedure>

In addition to the following instructions, refer to Fig 4-1.

#### (1) Attaching the stem connector

Step	Procedure
1	Apply an anti-galling agent*1 to the valve stem.
2	Screw the hex nut and stem connector onto the valve stem so that the dimension indicated in Fig 4-1 is achieved. Make sure that the hole at the top of the stem connector will be aligned with the center of the actuator, which will be set on the valve body afterward.

#### (2) Installing the actuator

Step	Procedure
1	Place the actuator on the bonnet and rotate it so that the matching marks that were placed before disassembly are aligned.
2	Attach the stem connector to the actuator with the stem connector screw.
3	Lock the stem connector with the hex nut.
4	Tighten the hex socket head set screws firmly at the bottom of the linkage.

#### (3) Inspection after reassembly

- Send various input signals to confirm that the control valve operates properly.
- Check seat leakage to confirm that the performance meets the specification.
- Carry out a pressure shell test for the valve body to confirm that fluid does not leak from between the valve and bonnet and from the gland.

## **Chapter 5. Disposal**

If this device is no longer needed, dispose of it appropriately as industrial waste, in accordance with local regulations. Do not reuse all or a part of the device.



## Chapter 6. Maintenance Information

Maintenance parts and our maintenance support are explained below. Please refer to the following when ordering consumables or if there is a problem with the control valve. For instructions on handling the ECM3000 control motor, refer to the user's manual indicated in chapter 1.

### List of parts

Refer to List of Parts in Appendix B.

### Ordering

Please contact the azbil Group and have the name and part number of the necessary parts ready.

### Maintenance service

The azbil Group offers various service programs that provide the advantage of maintenance know-how accumulated over a long period.

We also offer a prompt response to problems in cooperation with our Quality Assurance Department.

Please contact the azbil Group for maintenance of the control valve.





# Appendix A Dimension and Weight

External dimensions and weight of the control valve are indicated in Table A-1. Note that dimensions and weight may vary depending on the optional specifications.

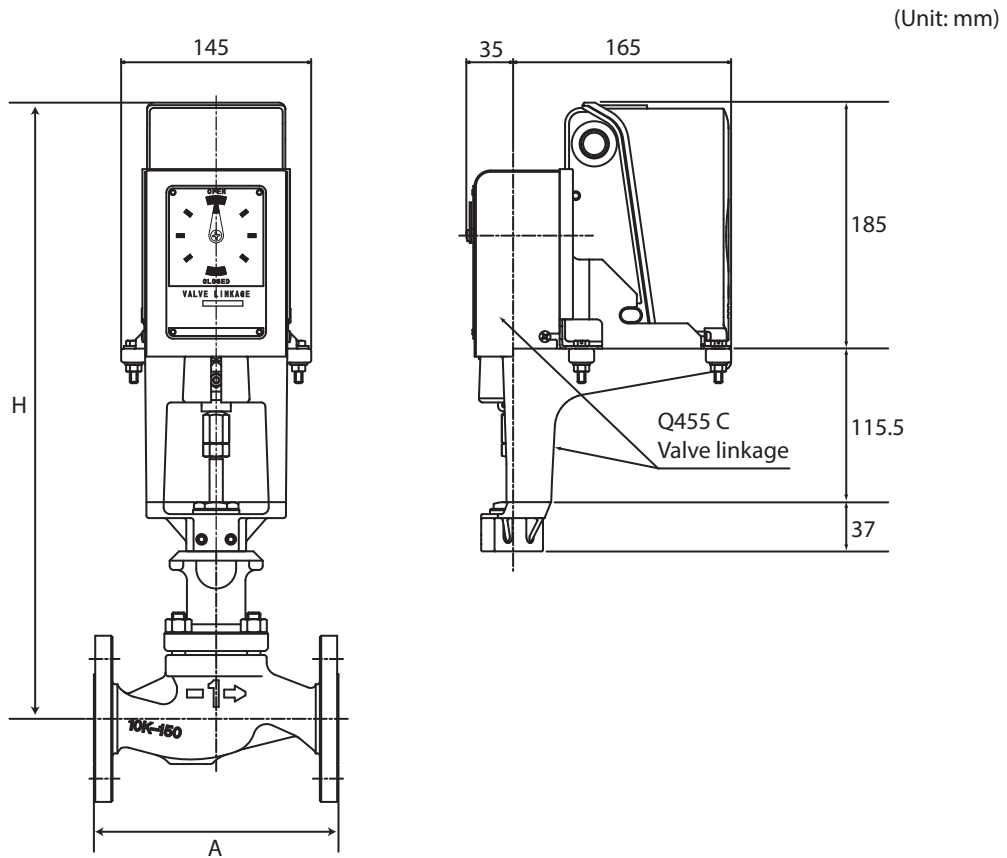

Fig. A-1. Face-to-face dimension and external dimensions

Table A-1. Face-to-face dimension, external dimensions and weight

Nominal diameter (inches)	Dimensions (mm)		Weight (kg)
	A	H	
1/2	184	465	13
3/4	184	465	14
1	184	465	15
1-1/2	222	465	22
2	254	465	25
2-1/2	276	485	38
3	298	485	39



# Appendix B List of Parts

## 1. Valve plug (plug stem assembly)

The valve plug and valve stem are united.

### 1-1. Valve plug (material: SUS316)

Name	Part No.	Qty.
1/2 in., Cv = 0.4, %C, plug stem assembly, SUS316	82557807-01100	1
1/2 in., Cv = 0.63, %C, plug stem assembly, SUS316	82557807-02100	1
1/2 in., Cv = 1.0, %C, plug stem assembly, SUS316	82557807-03100	1
1/2 in., Cv = 2.5, %C, plug stem assembly, SUS316	82557807-04100	1
1/2 in., Cv = 4.0, %C, plug stem assembly, SUS316	82557807-05100	1
3/4 in., Cv = 0.4, %C, plug stem assembly, SUS316	82557807-01100	1
3/4 in., Cv = 0.63, %C, plug stem assembly, SUS316	82557807-02100	1
3/4 in., Cv = 1.0, %C, plug stem assembly, SUS316	82557807-03100	1
3/4 in., Cv = 2.5, %C, plug stem assembly, SUS316	82557807-04100	1
3/4 in., Cv = 4.0, %C, plug stem assembly, SUS316	82557807-05100	1
3/4 in., Cv = 8.0, %C, plug stem assembly, SUS316	82557807-06100	1
1 in., Cv = 0.4, %C, plug stem assembly, SUS316	82557807-01100	1
1 in., Cv = 0.63, %C, plug stem assembly, SUS316	82557807-02100	1
1 in., Cv = 1.0, %C, plug stem assembly, SUS316	82557807-03100	1
1 in., Cv = 2.5, %C, plug stem assembly, SUS316	82557807-04100	1
1 in., Cv = 4.0, %C, plug stem assembly, SUS316	82557807-05100	1
1 in., Cv = 8.0, %C, plug stem assembly, SUS316	82557807-06100	1
1 in., Cv = 14, %C, plug stem assembly, SUS316	82557807-07100	1
1-1/2 × 1 in. (Cv = 14), %C, plug stem assembly, SUS316	82557807-07100	1
1-1/2 × 1-1/2 in. (Cv = 30), %C, plug stem assembly, SUS316	82557807-09100	1
2 × 2 in. (Cv = 50), %C, plug stem assembly, SUS316	82557807-10100	1
2-1/2 × 2-1/2 in. (Cv = 70), %C, plug stem assembly, SUS316	82557807-11100	1
3 × 3 in. (Cv = 100), %C, plug stem assembly, SUS316	82557807-12100	1

### 1-2. Valve plug (material: SUS316ST)

Name	Part No.	Qty.
1/2 in., Cv = 0.4, %C, plug stem assembly, SUS316ST	82557807-01200	1
1/2 in., Cv = 0.63, %C, plug stem assembly, SUS316ST	82557807-02200	1
1/2 in., Cv = 1.0, %C, plug stem assembly, SUS316ST	82557807-03200	1
1/2 in., Cv = 2.5, %C, plug stem assembly, SUS316ST	82557807-04200	1
1/2 in., Cv = 4.0, %C, plug stem assembly, SUS316ST	82557807-05200	1
3/4 in., Cv = 0.4, %C, plug stem assembly, SUS316ST	82557807-01200	1
3/4 in., Cv = 0.63, %C, plug stem assembly, SUS316ST	82557807-02200	1
3/4 in., Cv = 1.0, %C, plug stem assembly, SUS316ST	82557807-03200	1
3/4 in., Cv = 2.5, %C, plug stem assembly, SUS316ST	82557807-04200	1
3/4 in., Cv = 4.0, %C, plug stem assembly, SUS316ST	82557807-05200	1
3/4 in., Cv = 8.0, %C, plug stem assembly, SUS316ST	82557807-06200	1
1 in., Cv = 0.4, %C, plug stem assembly, SUS316ST	82557807-01200	1
1 in., Cv = 0.63, %C, plug stem assembly, SUS316ST	82557807-02200	1
1 in., Cv = 1.0, %C, plug stem assembly, SUS316ST	82557807-03200	1
1 in., Cv = 2.5, %C, plug stem assembly, SUS316ST	82557807-04200	1
1 in., Cv = 4.0, %C, plug stem assembly, SUS316ST	82557807-05200	1
1 in., Cv = 8.0, %C, plug stem assembly, SUS316ST	82557807-06200	1
1 in., Cv = 14, %C, plug stem assembly, SUS316ST	82557807-07200	1
1-1/2 × 1 in. (Cv = 14), %C, plug stem assembly, SUS316ST	82557807-07200	1
1-1/2 × 1-1/2 in. (Cv = 30), %C, plug stem assembly, SUS316ST	82557807-09200	1
2 × 2 in. (Cv = 50), %C, plug stem assembly, SUS316ST	82557807-10200	1
2-1/2 × 2-1/2 in. (Cv = 70), %C, plug stem assembly, SUS316ST	82557807-11200	1
3 × 3 in. (Cv = 100), %C, plug stem assembly, SUS316ST	82557807-12200	1

1-3. Valve plug (material: SUS316)(for PTFE soft seat)

Name	Part No.	Qty.
1/2 in., Cv = 0.4, %C, plug stem assembly, SUS316	82557808-01100	1
1/2 in., Cv = 0.63, %C, Plug stem assembly, SUS316	82557808-02100	1
1/2 in., Cv = 1.0, %C, plug stem assembly, SUS316	82557808-03100	1
1/2 in., Cv = 2.5, %C, plug stem assembly, SUS316	82557808-04100	1
1/2 in., Cv = 4.0, %C, plug stem assembly, SUS316	82557808-05100	1
3/4 in., Cv = 0.4, %C, plug stem assembly, SUS316	82557808-01100	1
3/4 in., Cv = 0.63, %C, plug stem assembly, SUS316	82557808-02100	1
3/4 in., Cv = 1.0, %C, plug stem assembly, SUS316	82557808-03100	1
3/4 in., Cv = 2.5, %C, plug stem assembly, SUS316	82557808-04100	1
3/4 in., Cv = 4.0, %C, plug stem assembly, SUS316	82557808-05100	1
3/4 in., Cv = 8.0, %C, plug stem assembly, SUS316	82557808-06100	1
1 in., Cv = 0.4, %C, plug stem assembly, SUS316	82557808-01100	1
1 in., Cv = 0.63, %C, plug stem assembly, SUS316	82557808-02100	1
1 in., Cv = 1.0, %C, plug stem assembly, SUS316	82557808-03100	1
1 in., Cv = 2.5, %C, plug stem assembly, SUS316	82557808-04100	1
1 in., Cv = 4.0, %C, plug stem assembly, SUS316	82557808-05100	1
1 in., Cv = 8.0, %C, plug stem assembly, SUS316	82557808-06100	1
1 in., Cv = 14, %C, plug stem assembly, SUS316	82557808-07100	1
1-1/2 × 1 in. (Cv = 14), %C, plug stem assembly, SUS316	82557808-07100	1
1-1/2 × 1-1/2 in. (Cv = 30), %C, plug stem assembly, SUS316	82557808-09100	1
2 × 1-1/2 in. (Cv = 30), %C, plug stem assembly, SUS316	82557808-09100	1
2 × 2 in. (Cv = 50), %C, plug stem assembly, SUS316	82557808-10100	1
2-1/2 × 2-1/2 in. (Cv = 70), %C, plug stem assembly, SUS316	82557808-11100	1
3 × 3 in. (Cv = 100), %C, plug stem assembly, SUS316	82557808-12100	1

## 2. Seat ring

### 2-1. Seat ring (material: SUS316)

Name	Part No.	Qty.
1/2 in., Cv = 0.4, %C, seat ring, SUS316	82553264-02200	1
1/2 in., Cv = 0.63, %C, seat ring, SUS316	82553264-02200	1
1/2 in., Cv = 1.0, %C, seat ring, SUS316	82553264-03200	1
1/2 in., Cv = 2.5, %C, seat ring, SUS316	82553264-04200	1
1/2 in., Cv = 4.0, %C, seat ring, SUS316	82553264-04200	1
3/4 in., Cv = 0.4, %C, seat ring, SUS316	82553264-02200	1
3/4 in., Cv = 0.63, %C, seat ring, SUS316	82553264-02200	1
3/4 in., Cv = 1.0, %C, seat ring, SUS316	82553264-03200	1
3/4 in., Cv = 2.5, %C, seat ring, SUS316	82553264-04200	1
3/4 in., Cv = 4.0, %C, seat ring, SUS316	82553264-04200	1
3/4 in., Cv = 8.0, %C, seat ring, SUS316	82553264-05200	1
1 in., Cv = 0.4, %C, seat ring, SUS316	82553264-02200	1
1 in., Cv = 0.63, %C, seat ring, SUS316	82553264-02200	1
1 in., Cv = 1.0, %C, seat ring, SUS316	82553264-03200	1
1 in., Cv = 2.5, %C, seat ring, SUS316	82553264-04200	1
1 in., Cv = 4.0, %C, seat ring, SUS316	82553264-04200	1
1 in., Cv = 8.0, %C, seat ring, SUS316	82553264-05200	1
1 in., Cv = 14, %C, seat ring, SUS316	82553008-10200	1
1-1/2 × 1-1/2 in. (Cv = 14), %C, seat ring, SUS316	82553010-04200	1
1-1/2 × 1-1/2 in. (Cv = 30), %C, seat ring, SUS316	82553010-02200	1
2 × 2 in. (Cv = 30), %C, seat ring, SUS316	82553010-02200	1
2 × 2 in. (Cv = 50), %C, seat ring, SUS316	82553010-01200	1
2-1/2 × 2-1/2 in. (Cv = 70), %C, seat ring, SUS316	82553012-02200	1
3 × 3 in. (Cv = 100), %C, seat ring, SUS316	82553012-01200	1

### 2-2. Seat ring (material: SUS316ST)

Name	Part No.	Qty.
1/2 in., Cv = 0.4, %C, seat ring, SUS316ST	82553264-02500	1
1/2 in., Cv = 0.63, %C, seat ring, SUS316ST	82553264-02500	1
1/2 in., Cv = 1.0, %C, seat ring, SUS316ST	82553264-03500	1
1/2 in., Cv = 2.5, %C, seat ring, SUS316ST	82553264-04500	1
1/2 in., Cv = 4.0, %C, seat ring, SUS316ST	82553264-04500	1
3/4 in., Cv = 0.4, %C, seat ring, SUS316ST	82553264-02500	1
3/4 in., Cv = 0.63, %C, seat ring, SUS316ST	82553264-02500	1
3/4 in., Cv = 1.0, %C, seat ring, SUS316ST	82553264-03500	1
3/4 in., Cv = 2.5, %C, seat ring, SUS316ST	82553264-04500	1
3/4 in., Cv = 4.0, %C, seat ring, SUS316ST	82553264-04500	1
3/4 in., Cv = 8.0, %C, seat ring, SUS316ST	82553264-05500	1
1 in., Cv = 0.4, %C, seat ring, SUS316ST	82553264-02500	1
1 in., Cv = 0.63, %C, seat ring, SUS316ST	82553264-02500	1
1 in., Cv = 1.0, %C, seat ring, SUS316ST	82553264-03500	1
1 in., Cv = 2.5, %C, seat ring, SUS316ST	82553264-04500	1
1 in., Cv = 4.0, %C, seat ring, SUS316ST	82553264-04500	1
1 in., Cv = 8.0, %C, seat ring, SUS316ST	82553264-05500	1
1 in., Cv = 14, %C, seat ring, SUS316ST	82553008-10500	1
1-1/2 × 1-1/2 in. (Cv = 14), %C, seat ring, SUS316ST	82553010-04500	1
1-1/2 × 1-1/2 in. (Cv = 30), %C, seat ring, SUS316ST	82553010-02500	1
2 × 2 in. (Cv = 30), %C, seat ring, SUS316ST	82553010-02500	1
2 × 2 in. (Cv = 50), %C, seat ring, SUS316ST	82553010-01500	1
2-1/2 × 2-1/2 in. (Cv = 70), %C, seat ring, SUS316ST	82553012-02500	1
3 × 3 in. (Cv = 100), %C, seat ring, SUS316ST	82553012-01500	1

2-3. Seat ring (material: SUS316)(for PTFE soft seat)

Name	Part No.	Qty.
1/2 in., Cv = 0.4, %T, seat ring, SUS316	82553928-20200	1
1/2 in., Cv = 0.63, %T, seat ring, SUS316	82553928-20200	1
1/2 in., Cv = 1.0, %T, seat ring, SUS316	82553928-30200	1
1/2 in., Cv = 2.5, %T, seat ring, SUS316	82553926-10200	1
1/2 in., Cv = 4.0, %T, seat ring, SUS316	82553926-10200	1
3/4 in., Cv = 0.4, %T, seat ring, SUS316	82553928-20200	1
3/4 in., Cv = 0.63, %T, seat ring, SUS316	82553928-20200	1
3/4 in., Cv = 1.0, %T, seat ring, SUS316	82553928-30200	1
3/4 in., Cv = 2.5, %T, seat ring, SUS316	82553926-10200	1
3/4 in., Cv = 4.0, %T, seat ring, SUS316	82553926-10200	1
3/4 in., Cv = 8.0, %T, seat ring, SUS316	82553926-20200	1
1 in., Cv = 0.4, %T, seat ring, SUS316	82553928-20200	1
1 in., Cv = 0.63, %T, seat ring, SUS316	82553928-20200	1
1 in., Cv = 1.0, %T, seat ring, SUS316	82553928-30200	1
1 in., Cv = 2.5, %T, seat ring, SUS316	82553926-10200	1
1 in., Cv = 4.0, %T, seat ring, SUS316	82553926-10200	1
1 in., Cv = 8.0, %T, seat ring, SUS316	82553926-20200	1
1 in., Cv = 14, %T, seat ring, SUS316	82553929-10200	1
1-1/2 × 1-1/2 in. (Cv = 14), %T, seat ring, SUS316	82553936-10200	1
1-1/2 × 1-1/2 in. (Cv = 30), %T, seat ring, SUS316	82553935-02200	1
2 × 2 in. (Cv = 30), %T, seat ring, SUS316	82553935-02200	1
2 × 2 in. (Cv = 50), %T, seat ring, SUS316	82553935-01200	1
2-1/2 × 2-1/2 in. (Cv = 70), %T, seat ring, SUS316	82553934-02200	1
3 × 3 in. (Cv = 100), %T, seat ring, SUS316	82553934-01200	1

**3. Upper bonnet**

Name	Part No.	Qty.
Upper bonnet, 1 in. or less, SCPH2	82557786-10100	1
Upper bonnet, 1 in. or less, SCS	82557787-10100	1
Upper bonnet, 1-1/2, 2 in., SCPH	82557788-10100	1
Upper bonnet, 1-1/2, 2 in., SCS	82557789-10100	1
Upper bonnet, 2-1/2, 3 in., SCPH2	82557791-10100	1
Upper bonnet, 2-1/2, 3 in., SCS	82557811-10100	1

**4. Gasket**

4-1. Gasket

Name	Part No.	Qty.
Gasket, 1 in. or smaller	82553016-10100	1
Gasket, 1/2 to 2 in.	82553016-20100	1
Gasket, 2-1/2 to 3 in.	82553016-30100	1

4-2. Seat ring gasket (only for a degreased model)

Name	Part No.	Qty.
Seat ring gasket, 1 in. or smaller	82660153-10100	1
Seat ring gasket, 1/2 to 2 in.	82660153-30100	1
Seat ring gasket, 2-1/2 to 3 in.	82553463-10100	1

## 5. Gland parts

### 5-1. PTFE packing

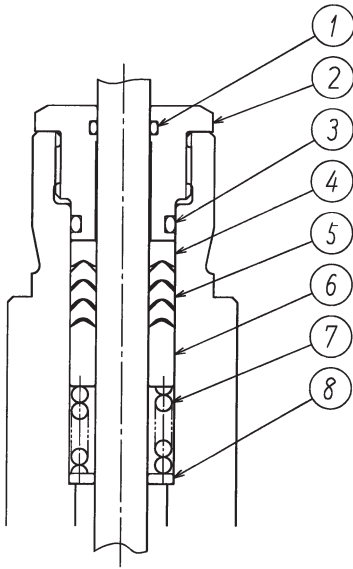

Key No.	Name	Part No.	Qty.
1	O-ring P10 AFLAS	82592220-80100	1
2	Packing nut	82509727-16600	1
3	O-ring P16 AFLAS	82592221-70100	1
4	Packing holder	82509735-10300	1
5	V-shape packing	82509736-10100	3
6	Packing retainer	82509737-10200	1
7	Spring	82509716-16600	1
8	Packing ring	82509714-16600	1





# Appendix C Main Parts to be Replaced

Parts of this control valve can be used for a long period of time, but the following parts should be replaced at every periodic inspection.

## **Location: valve body**

Gland packing

Gaskets



基于 SJ/T11364-2014「电子电气产品有害物质限制使用标识要求」的表示式样

产品中有害物质的名称及含量

部件名称	有害物质					
	铅 (Pb)	汞 (Hg)	镉 (Cd)	六价铬 (Cr(VI))	多溴联苯 (PBB)	多溴二苯醚 (PBDE)
印制□路板	×	○	○	○	○	○
控制马达	×	○	○	○	○	○
支架	×	○	○	○	○	○

本表根据 SJ/T11364 的规定编制。  
 ○：表示□有害物□在□部件所有均□材料中的含量均在 GB/T 26572 □定的限量要求以下。  
 ×：表示□有害物□至少在□部件的某一均□材料中的含量超出 GB/T 26572 □定的限量要求。



# Terms and Conditions

We would like to express our appreciation for your purchase and use of Azbil Corporation's products. You are required to acknowledge and agree upon the following terms and conditions for your purchase of Azbil Corporation's products (system products, field instruments, control valves, and control products), unless otherwise stated in any separate document, including, without limitation, estimation sheets, written agreements, catalogs, specifications and instruction manuals.

## 1. Warranty period and warranty scope

### 1.1 Warranty period

Azbil Corporation's products shall be warranted for one (1) year from the date of your purchase of the said products or the delivery of the said products to a place designated by you.

### 1.2 Warranty scope

In the event that Azbil Corporation's product has any failure attributable to azbil during the aforementioned warranty period, Azbil Corporation shall, without charge, deliver a replacement for the said product to the place where you purchased, or repair the said product and deliver it to the aforementioned place. Notwithstanding the foregoing, any failure falling under one of the following shall not be covered under this warranty:

- (1) Failure caused by your improper use of azbil product (noncompliance with conditions, environment of use, precautions, etc. set forth in catalogs, specifications, instruction manuals, etc.);
- (2) Failure caused for other reasons than Azbil Corporation's product;
- (3) Failure caused by any modification or repair made by any person other than Azbil Corporation or Azbil Corporation's subcontractors;
- (4) Failure caused by your use of Azbil Corporation's product in a manner not conforming to the intended usage of that product;
- (5) Failure that the state-of-the-art at the time of Azbil Corporation's shipment did not allow Azbil Corporation to predict; or
- (6) Failure that arose from any reason not attributable to Azbil Corporation, including, without limitation, acts of God, disasters, and actions taken by a third party.

Please note that the term "warranty" as used herein refers to equipment-only-warranty, and Azbil Corporation shall not be liable for any damages, including direct, indirect, special, incidental or consequential damages in connection with or arising out of Azbil Corporation's products.

## 2. Ascertainment of suitability

You are required to ascertain the suitability of Azbil Corporation's product in case of your use of the same with your machinery, equipment, etc. (hereinafter referred to as "Equipment") on your own responsibility, taking the following matters into consideration:

- (1) Regulations and standards or laws that your Equipment is to comply with.
- (2) Examples of application described in any documents provided by Azbil Corporation are for your reference purpose only, and you are required to check the functions and safety of your Equipment prior to your use.
- (3) Measures to be taken to secure the required level of the reliability and safety of your Equipment in your use

Although azbil is constantly making efforts to improve the quality and reliability of Azbil Corporation's products, there exists a possibility that parts and machinery may break down.

You are required to provide your Equipment with safety design such as fool-proof design, \*1 and fail-safe design\*2 (anti-flame propagation design, etc.), whereby preventing any occurrence of physical injuries, fires, significant damage, and so forth. Furthermore, fault avoidance, \*3 fault tolerance,\*4 or the like should be incorporated so that the said Equipment can satisfy the level of reliability and safety required for your use.

\*1. A design that is safe even if the user makes an error.

\*2. A design that is safe even if the device fails.

\*3. Avoidance of device failure by using highly reliable components, etc.

\*4. The use of redundancy.

## 3. Precautions and restrictions on application

Azbil Corporation's products other than those explicitly specified as applicable (e.g. azbil Limit Switch For Nuclear Energy) shall not be used in a nuclear energy controlled area (radiation controlled area).

Any Azbil Corporation's products shall not be used for/with medical equipment.

The products are for industrial use. Do not allow general consumers to install or use any Azbil Corporation's product.

However, azbil products can be incorporated into products used by general consumers. If you intend to use a product for that purpose, please contact one of our sales representatives.

In addition,

you are required to conduct a consultation with our sales representative and understand detail specifications, cautions for operation, and so forth by reference to catalogs, specifications, instruction manual, etc. in case that you intend to use azbil product for any purposes specified in (1) through (6) below.

Moreover, you are required to provide your Equipment with fool-proof design, fail-safe design, anti-flame propagation design, fault avoidance, fault tolerance, and other kinds of protection/safety circuit design on your own responsibility to ensure reliability and safety, whereby preventing problems caused by failure or nonconformity.

- (1) For use under such conditions or in such environments as not stated in technical documents, including catalogs, specification, and instruction manuals

- (2) For use of specific purposes, such as:
  - \* Nuclear energy/radiation related facilities  
[For use outside nuclear energy controlled areas] [For use of Azbil Corporation's Limit Switch For Nuclear Energy]
  - \* Machinery or equipment for space/sea bottom
  - \* Transportation equipment  
[Railway, aircraft, vessels, vehicle equipment, etc.]
  - \* Antidisaster/crime-prevention equipment
  - \* Burning appliances
  - \* Electrothermal equipment
  - \* Amusement facilities
  - \* Facilities/applications associated directly with billing
- (3) Supply systems such as electricity/gas/water supply systems, large-scale communication systems, and traffic/air traffic control systems requiring high reliability
- (4) Facilities that are to comply with regulations of governmental/public agencies or specific industries
- (5) Machinery or equipment that may affect human lives, human bodies or properties
- (6) Other machinery or equipment equivalent to those set forth in items (1) to (5) above which require high reliability and safety

#### 4. Precautions against long-term use

Use of Azbil Corporation's products, including switches, which contain electronic components, over a prolonged period may degrade insulation or increase contact-resistance and may result in heat generation or any other similar problem causing such product or switch to develop safety hazards such as smoking, ignition, and electrification. Although acceleration of the above situation varies depending on the conditions or environment of use of the products, you are required not to use any Azbil Corporation's products for a period exceeding ten (10) years unless otherwise stated in specifications or instruction manuals.

#### 5. Recommendation for renewal

Mechanical components, such as relays and switches, used for Azbil Corporation's products will reach the end of their life due to wear by repetitious open/close operations. In addition, electronic components such as electrolytic capacitors will reach the end of their life due to aged deterioration based on the conditions or environment in which such electronic components are used. Although acceleration of the above situation varies depending on the conditions or environment of use, the number of open/close operations of relays, etc. as prescribed in specifications or instruction manuals, or depending on the design margin of your machine or equipment, you are required to renew any Azbil Corporation's products every 5 to 10 years unless otherwise specified in specifications or instruction manuals. System products, field instruments (sensors such as pressure/flow/level sensors, regulating valves, etc.) will reach the end of their life due to aged deterioration of parts. For those parts that will reach the end of their life due to aged deterioration, recommended replacement cycles are prescribed. You are required to replace parts based on such recommended replacement cycles.

#### 6. Other precautions

Prior to your use of Azbil Corporation's products, you are required to understand and comply with specifications (e.g., conditions and environment of use), precautions, warnings/cautions/notices as set forth in the technical documents prepared for individual Azbil Corporation's products, such as catalogs, specifications, and instruction manuals to ensure the quality, reliability, and safety of those products.

#### 7. Changes to specifications

Please note that the descriptions contained in any documents provided by azbil are subject to change without notice for improvement or for any other reason. For inquires or information on specifications as you may need to check, please contact our branch offices or sales offices, or your local sales agents.

#### 8. Discontinuance of the supply of products/parts

Please note that the production of any Azbil Corporation's product may be discontinued without notice. For repairable products, we will, in principle, undertake repairs for five (5) years after the discontinuance of those products. In some cases, however, we cannot undertake such repairs for reasons, such as the absence of repair parts. For system products, field instruments, we may not be able to undertake parts replacement for similar reasons.

#### 9. Scope of services

Prices of Azbil Corporation's products do not include any charges for services such as engineer dispatch service. Accordingly, a separate fee will be charged in any of the following cases:

- (1) Installation, adjustment, guidance, and attendance at a test run
- (2) Maintenance, inspection, adjustment, and repair
- (3) Technical guidance and technical education
- (4) Special test or special inspection of a product under the conditions specified by you

Please note that we cannot provide any services as set forth above in a nuclear energy controlled area (radiation controlled area) or at a place where the level of exposure to radiation is equivalent to that in a nuclear energy controlled area.



---

<b>Document Number:</b>	CM2-ACT100-2002
<b>Document Name:</b>	NEW 10-III Electric Single-Seated Control Valve Model ACT User's Manual
<b>Date:</b>	1st edition : Aug. 2017
<b>Issued/Edited by:</b>	Azbil Corporation

---

Azbil Corporation